



MANUALS & DOCUMENTS

ZENDIT

ZENDIT

EN	3
MANUALS & DOCUMENTS	
DE	24
ANLEITUNGEN UND DOKUMENTE	
FR	45
MANUELS ET DOCUMENTS	
IT	66
MANUALI E DOCUMENTI	
ES	87
MANUALES Y DOCUMENTOS	

MANUALS & DOCUMENTS





GENERAL AND SAFETY INSTRUCTIONS

This technical guide may use the following 3 icons. Each icon denotes that the following precautions should be taken:

WARNING:

Improper use or failure to follow directions may result in serious injury or death. These tasks are technically difficult and, if not performed properly, could cause damage to your bicycle or void your warranty.

CAUTION:

Improper use or failure to follow directions may result in minor injuries. These tasks are technically difficult and, if not performed properly, could cause damage to your bicycle or void your warranty.

INFORMATION

Essential information to correctly perform this task in order to avoid any damage to the bicycle or void the warranty, without any risk to people.

FURTHER CONSIDERATIONS

- Using non-original spare parts can lead to damage, malfunctions and accidents with potentially serious consequences.
- Some of the steps described in this manual require skills beyond those of the average bicycle user. If you are unable to follow any of these steps, please arrange for your bicycle to be serviced and replaced at an authorized Mondraker service centre. Installing spare parts incorrectly may result in malfunctions, accidents, injuries and void the warranty.

CLEANING AND MAINTENANCE

- Once the parts have been disassembled, components to be reused should be cleaned, greased and thread sealed (if necessary).

SYMBOL LEGEND



Medium grade threadlocker. Loctite 243.



Quality synthetic assembly grease.



Special carbon friction grease.



1. DIMENSIONS

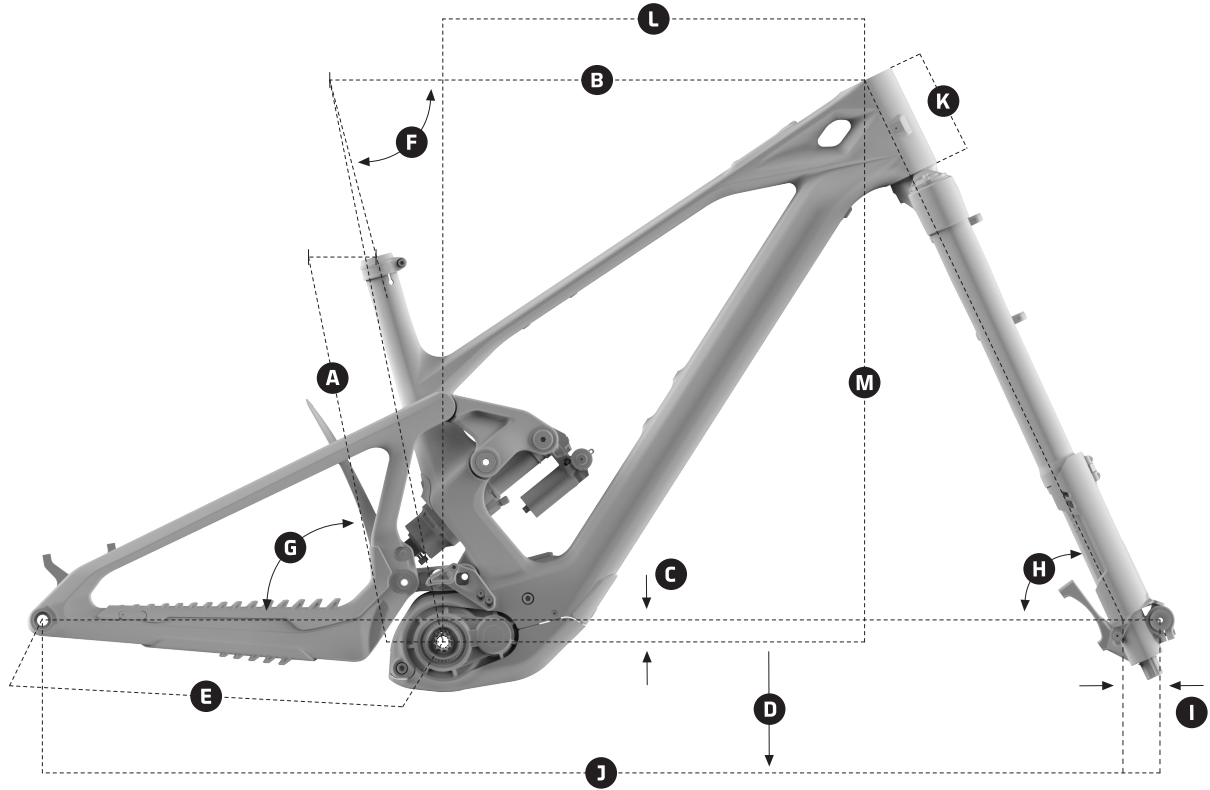

ZENDIT (FLIP CHIP STANDARD POSITION)

FRAME SIZE	S	M	ML	L	XL
A Seat Tube Length	380 mm	410 mm	435 mm	460 mm	490 mm
B Top Tube Length	586 mm	606 mm	628 mm	650 mm	672 mm
C Bottom Bracket Drop	6 mm	6 mm	6 mm	6 mm	6 mm
D Bottom Bracket Height	345 mm	345 mm	345 mm	345 mm	345 mm
E Chainstay Length	450 mm	450 mm	450 mm	455 mm	455 mm
F Seat Tube Angle, Actual	73,5°	73,5°	73,5°	73,5°	73,5°
G Seat Tube Angle, Effective	77,0°	77,0°	77,0°	77,0°	77,0°
H Headtube Angle	63,5°	63,5°	63,5°	63,5°	63,5°
I Fork Offset	44 mm	44 mm	44 mm	44 mm	44 mm
J Wheelbase	1241 mm	1261 mm	1286 mm	1315 mm	1339 mm
K Headtube Length	110 mm	110 mm	120 mm	130 mm	140 mm
L Reach	440 mm	460 mm	480 mm	500 mm	520 mm
M Stack	631 mm	631 mm	640 mm	649 mm	658 mm

*Chainstay length increase in 7mm when fit a 29" rear wheel



1. DIMENSIONS

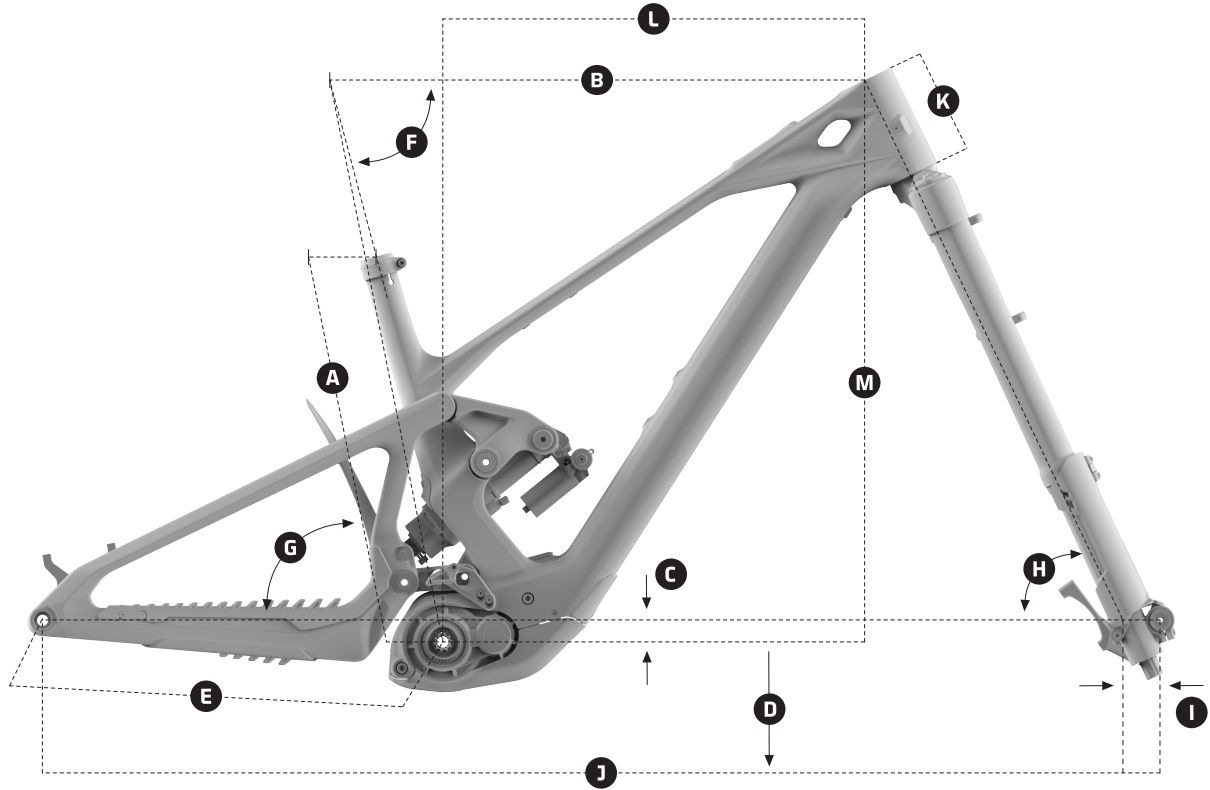

ZENDIT (FLIP CHIP LOW POSITION)

FRAME SIZE	S	M	ML	L	XL
A Seat Tube Length	380 mm	410 mm	435 mm	460 mm	490 mm
B Top Tube Length	586 mm	606 mm	629 mm	651 mm	673 mm
C Bottom Bracket Drop	11 mm	11 mm	11 mm	11 mm	11 mm
D Bottom Bracket Height	340 mm	340 mm	340 mm	340 mm	340 mm
E Chainstay Length	451 mm	451 mm	451 mm	456 mm	456 mm
F Seat Tube Angle, Actual	73,15°	73,15°	73,15°	73,15°	73,15°
G Seat Tube Angle, Effective	76,65°	76,65°	76,65°	76,65°	76,65°
H Headtube Angle	63.15°	63.15°	63.15°	63.15°	63.15°
I Fork Offset	44 mm	44 mm	44 mm	44 mm	44 mm
J Wheelbase	1242 mm	1262 mm	1287 mm	1316 mm	1340 mm
K Headtube Length	110 mm	110 mm	120 mm	130 mm	140 mm
L Reach	436 mm	456 mm	476 mm	496 mm	516 mm
M Stack	633 mm	634 mm	643 mm	652 mm	661 mm

*Chainstay length increase in 7mm when fit a 29" rear wheel



2. FRAME TECHNICAL SPECIFICATIONS

FRAME SIZES	S / M / ML / L / XL
FRONT WHEEL SIZE	29"
FRONT AXLE	110mm x 20mm (BOOST)
REAR WHEEL SIZE	27.5" / 29"
REAR AXLE	148mm x 12mm (BOOST)
REAR SHAFT	12X148 P1.0 L180
NUMBER OF BOTTLE CAGES	Down tube for bottle cage, top tube for accessories.
DRIVE UNIT	Avinox
BOTTOM BRACKET	Avinox
BATTERY	800Wh
RANGE EXTENDER	-
REAR WHEEL TRAVEL	165mm
REAR SHOCK	205 x 65mm TRUNNION, 30 x 8mm
FRONT WHEEL TRAVEL	170mm
SEATPOST DIAMETER	31.6mm / 36.9mm
CHAIN LINE	55mm
HEADSET	ZS56 / ZS56, 1-1/8", 1.5"
MAXIMUM CHAINRING SIZE	36T
REAR BRAKE	POST MOUNT, DIRECT 220mm max
MAXIMUM COMPATIBLE WHEEL SIZE	29" x 2.6" (66-622)

3. SEATPOST INSERTION DEPTH

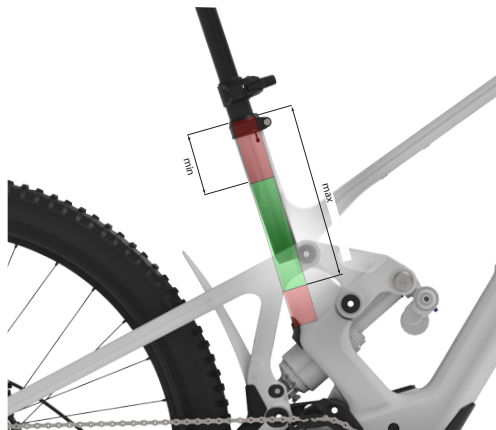

FRAME SIZE	MIN. (mm)	MAX. (mm)
XL	100	300
L	100	270
ML	100	244
M	100	220
S	100	190



4. DRIVE COMPONENTS

4.1. CHAIN GUIDE

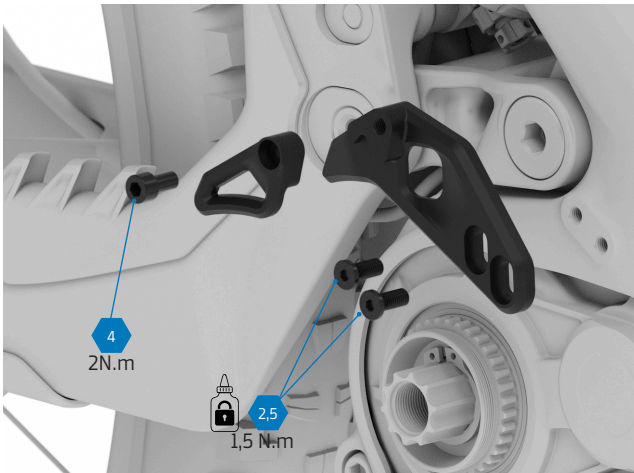

4.2. CHAINRING

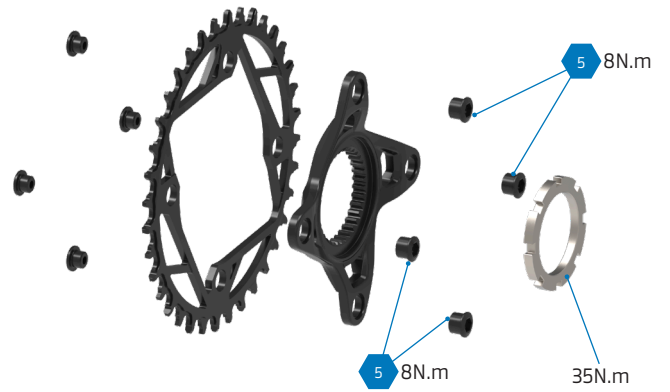

5. MOTOR COVER

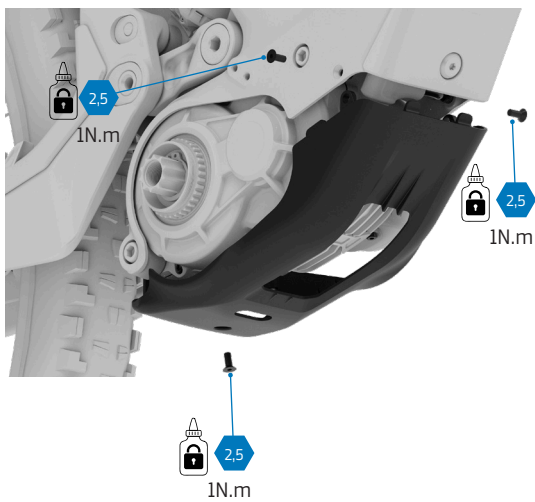



6. MOTOR

6.1. FIXING THE MOTOR TO THE FRAME

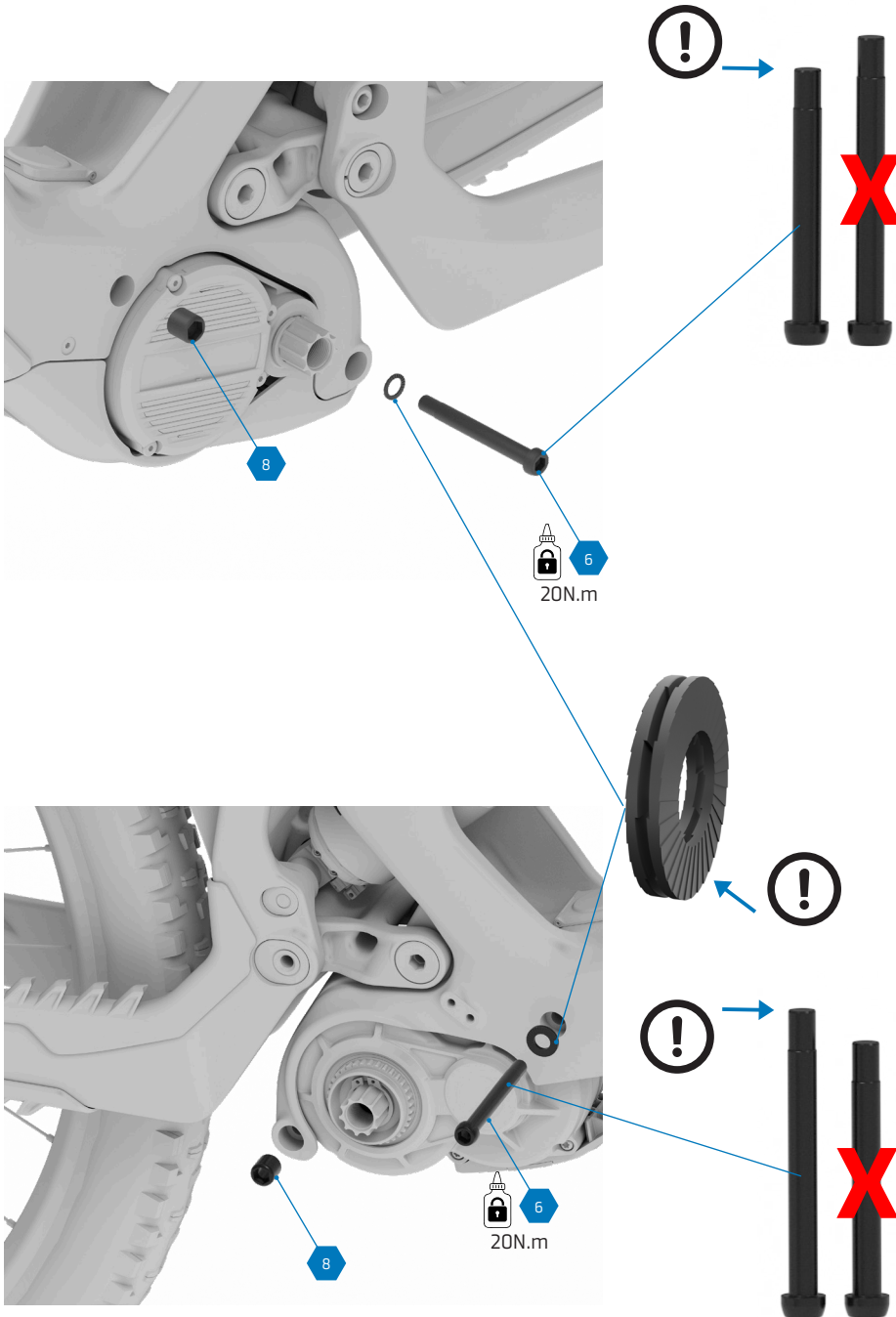

6. MOTOR

6.2. SPACERS BETWEEN THE FRAME AND THE MOTOR

This step is only necessary when replacing the motor or the frame with a new one. Motors and frames assembled at Mondraker already come with the correct spacers.

A special AVINOX tool is required to perform this task.

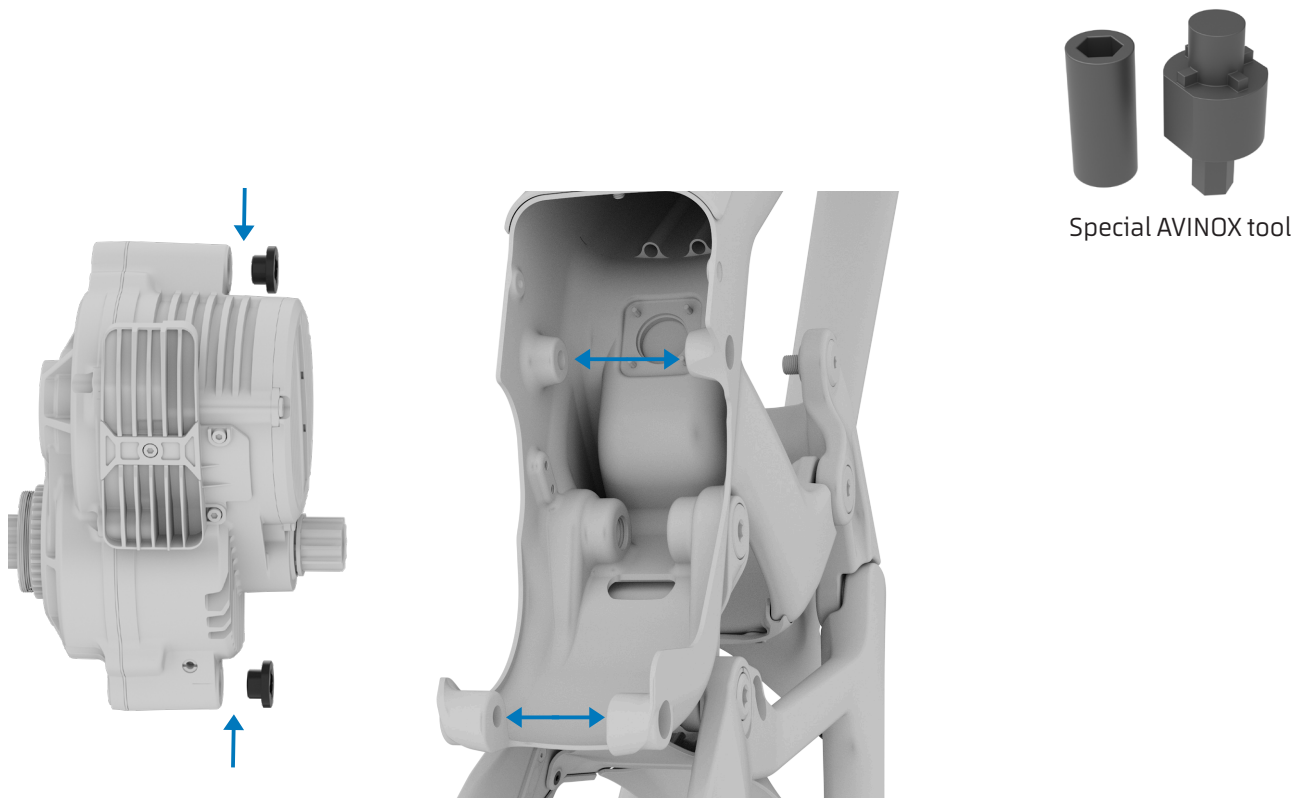

In the event of replacing the frame or the motor, it is necessary to measure the distance between the carbon mounting surfaces in the motor housing using a caliper. Depending on this measurement, the corresponding washers or spacers must be installed between the motor and the bolt, according to the values indicated in the table. It is imperative to verify the measurements at both the front and rear mounting points, as they may vary and therefore require a different number of spacers. The final tightening of the bolts must be performed using the special AVINOX tool, applying a torque of **5 Nm**.

A = X - 56.7mm (Front hanging point) A = Y - 47.1mm (Rear hanging point)

Clearance between the frame and the motor	The number of mounting point washers
$A < 0.25\text{mm}$	0
$0.25\text{mm} \leq A < 0.50\text{mm}$	0
$0.50\text{mm} \leq A < 0.75\text{mm}$	2
$0.75\text{mm} \leq A < 1.00\text{mm}$	3
$A = 1.00\text{mm}$	4
$A > 1.00\text{mm}$	Frame tolerance is abnormal: the drive unit cannot be installed.



7. CHARGING PORT

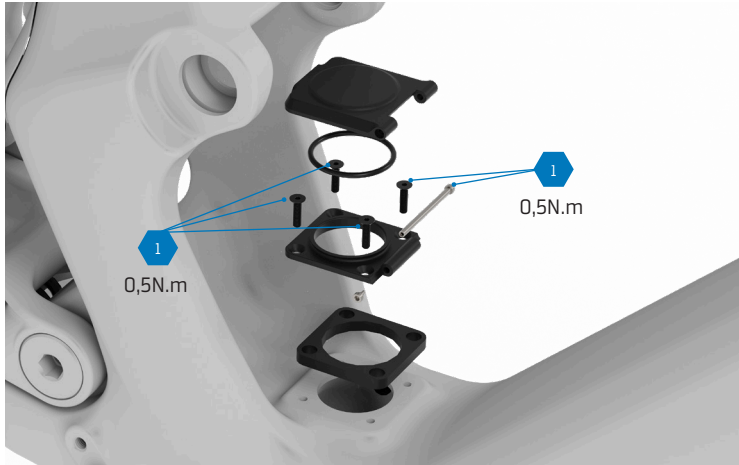

8. INTERNAL CABLE ROUTING

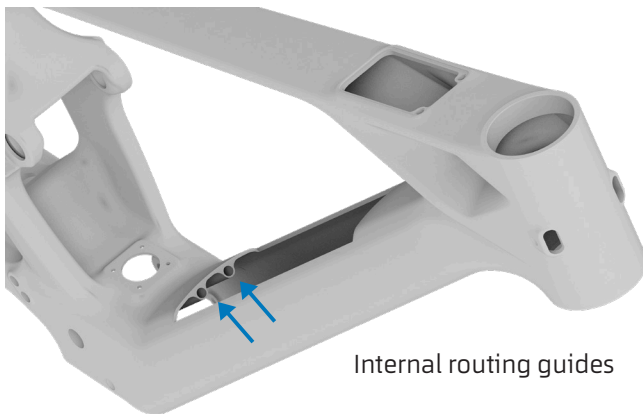
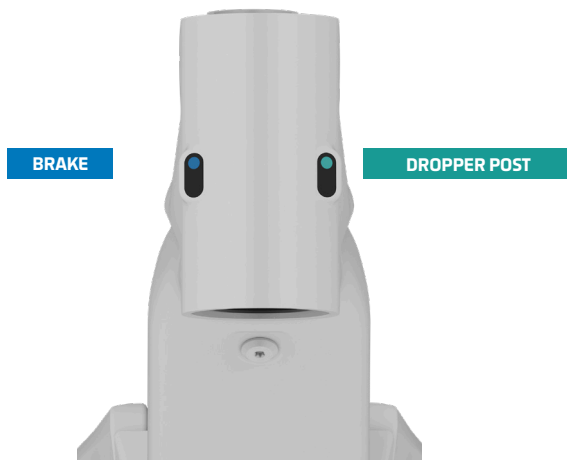



8. INTERNAL CABLE ROUTING

8.1. CABLE PORTS

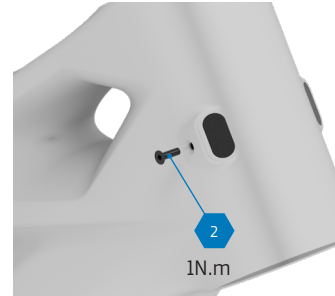
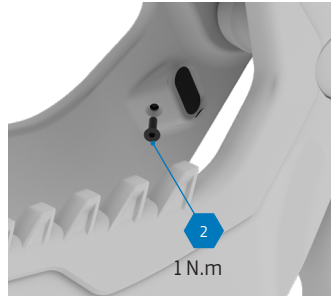
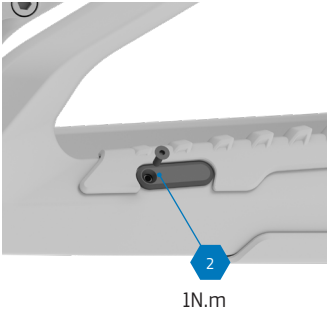

8.2. SPEED SENSOR PORT

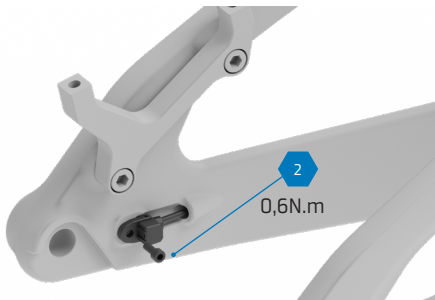

9. BATTERY MOUNTING BOLTS

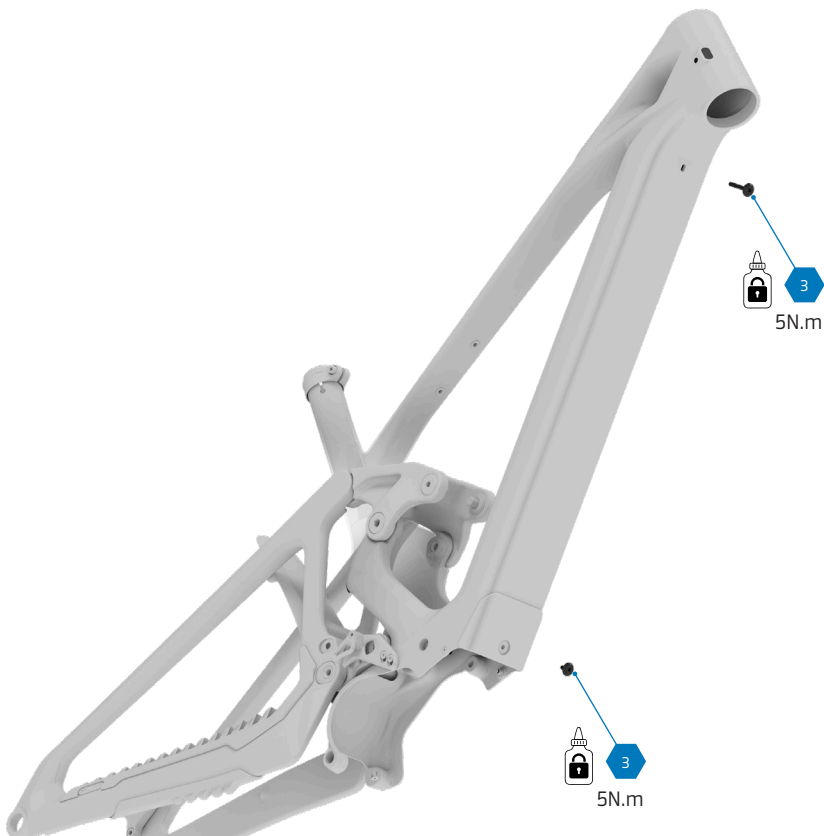



10. DISPLAY



11. WIRELESS CONTROLLER

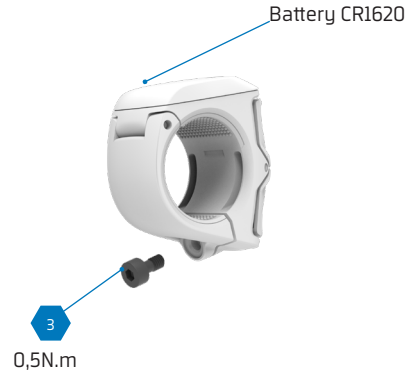

12. FENDERS

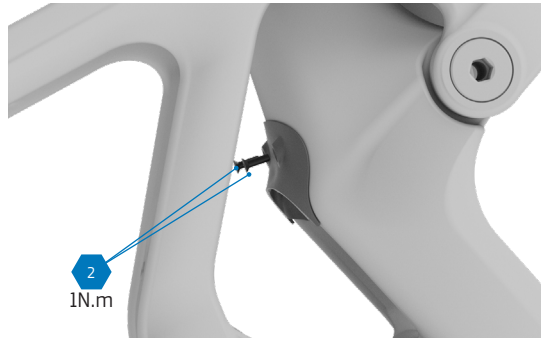
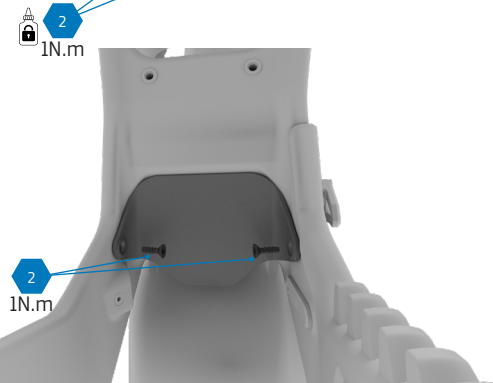
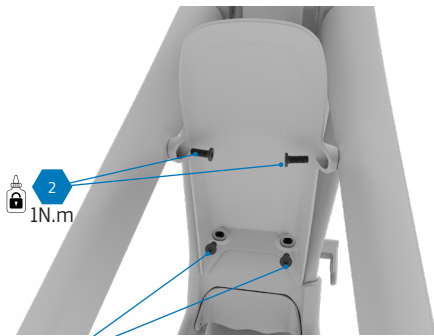

15. SEATPOST CLAMP



We recommend using carbon friction paste on the seatpost



16. UPPER LINK INSTALLATION GUIDE



Use Loctite 243 on the threads.
Pro Tip: Instead of applying the threadlocker to the bolt, you can apply it directly to the internal thread of the bicycle frame. This prevents contaminating other components with threadlocker when inserting the bolt.

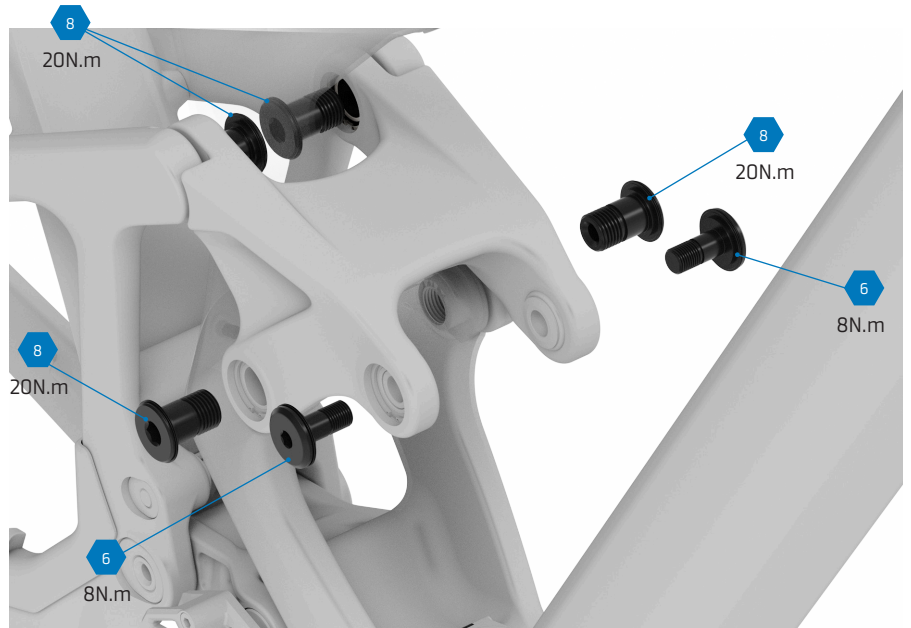
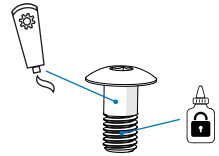

Apply grease to the shaft for the main screws and Loctite 243 to the threads.

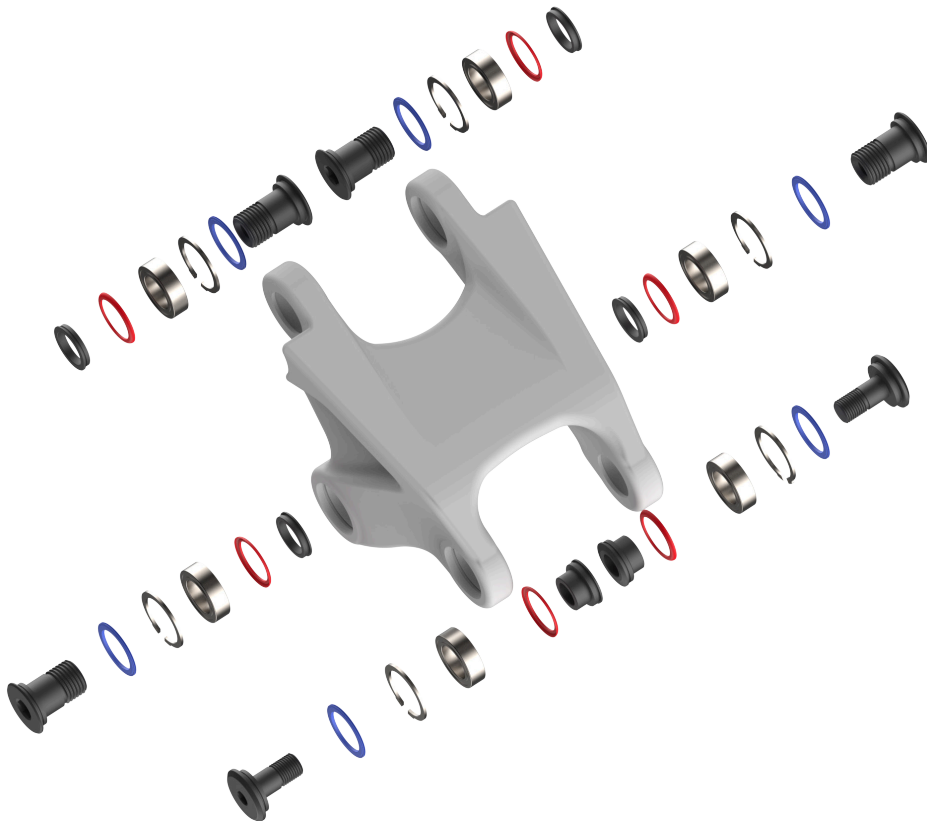

Pay special attention to the position of the rubber seals.



Apply grease to the friction surfaces while avoiding contaminating the threads.

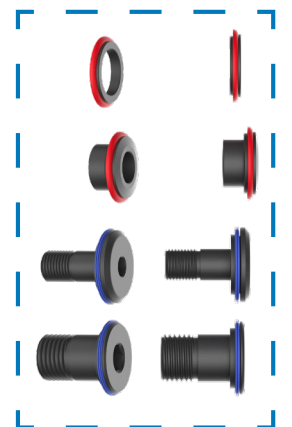



17. LOWER LINK INSTALLATION GUIDE

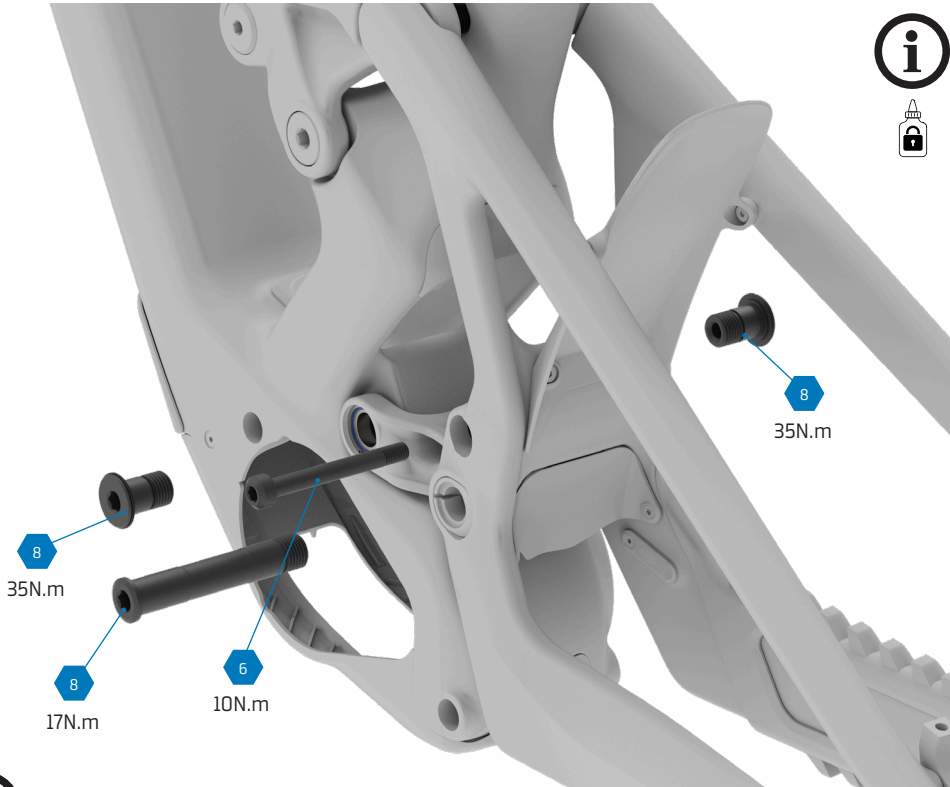

Use Loctite 243 on the threads.
Pro Tip: Instead of applying the threadlocker to the bolt, you can apply it directly to the internal thread of the bicycle frame. This prevents contaminating other components with threadlocker when inserting the bolt.

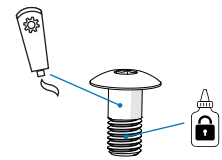

Apply grease to the shaft for the main screws and Loctite 243 to the threads.

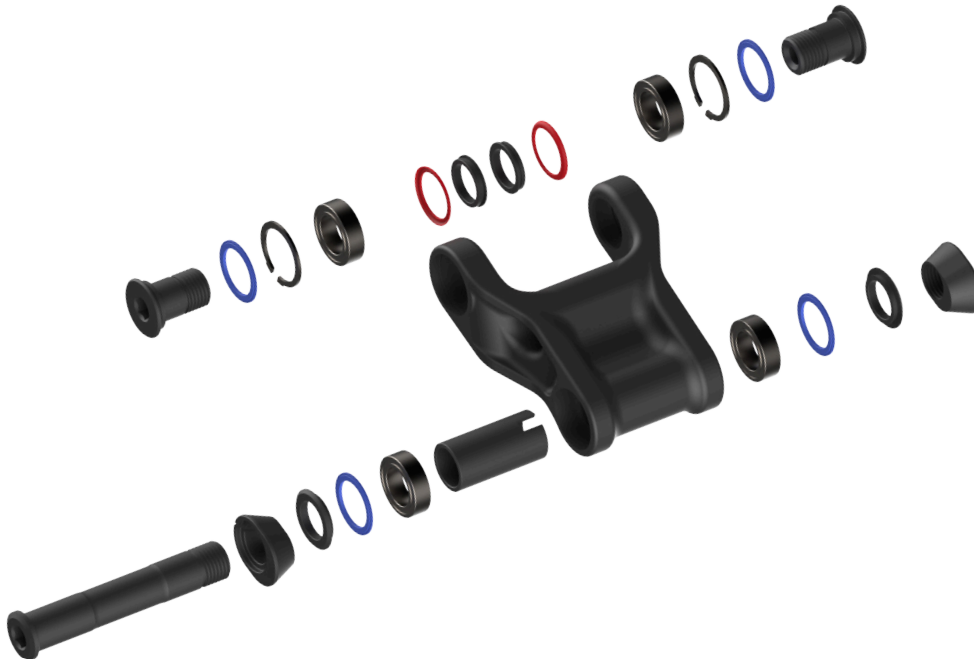

Pay special attention to the position of the rubber seals.



Apply grease to the friction surfaces while avoiding contaminating the threads.

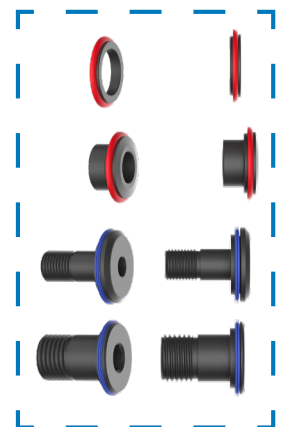



18. FLIP CHIP

18.1 FLIP CHIP FOR 27.5"-29" WHEEL SIZE CHANGE

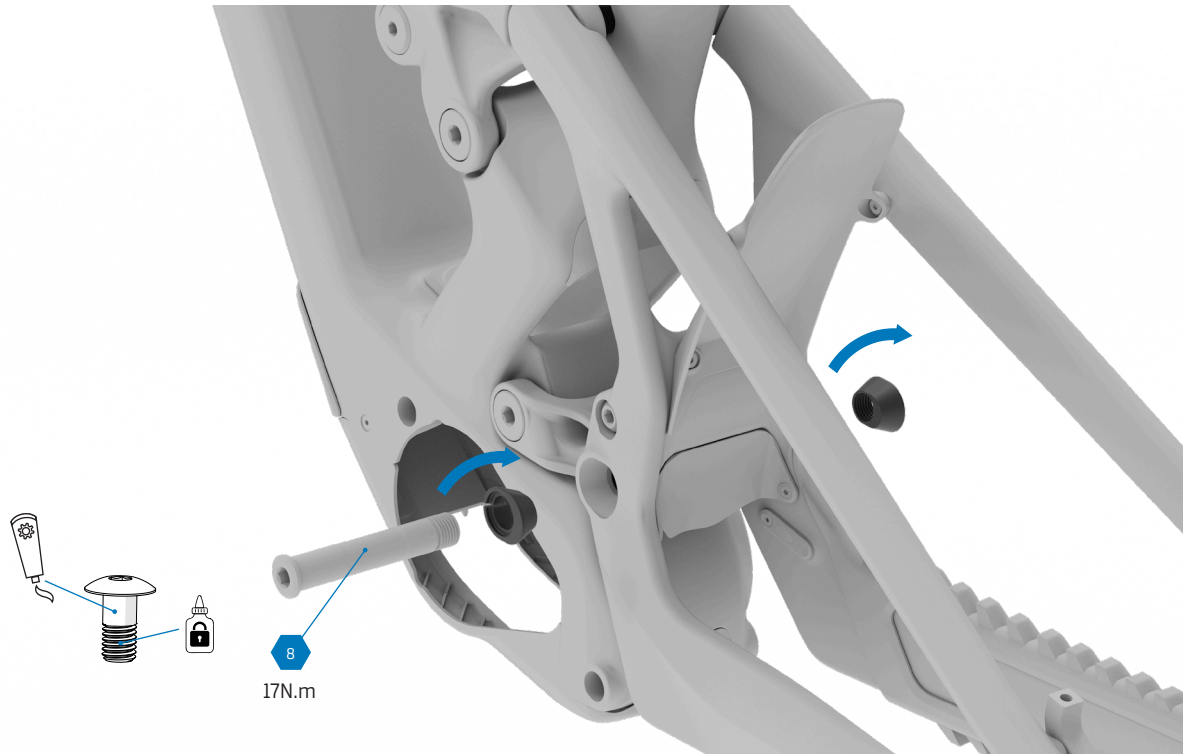

- ⚠ Apply grease to the shaft for the main screws and Loctite 243 to the threads.
- ⚠ Apply grease to the friction surfaces while avoiding contaminating the threads.
- ⚠ When switching from 27.5" to 29" wheels, ensure you add 2 extra links to the chain length. A 27.5" setup uses 120 links, while a 29" setup uses 122 links. Additionally, connect the Avinox Ride app and update the wheel set-up configurations.

18.2 FLIP CHIP FOR STD - LOW KINEMATICS CHANGE

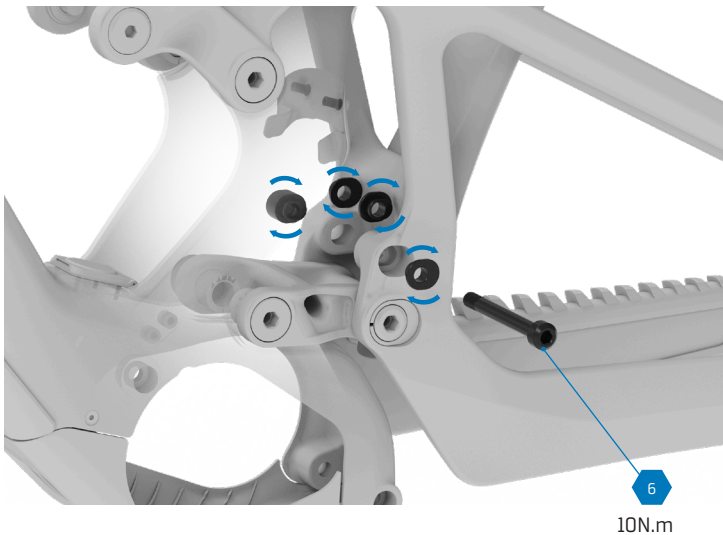

The flip chip for the kinematics change consists of 4 parts: 2 external and 2 internal.



20. SPARE PARTS

ZENDIT

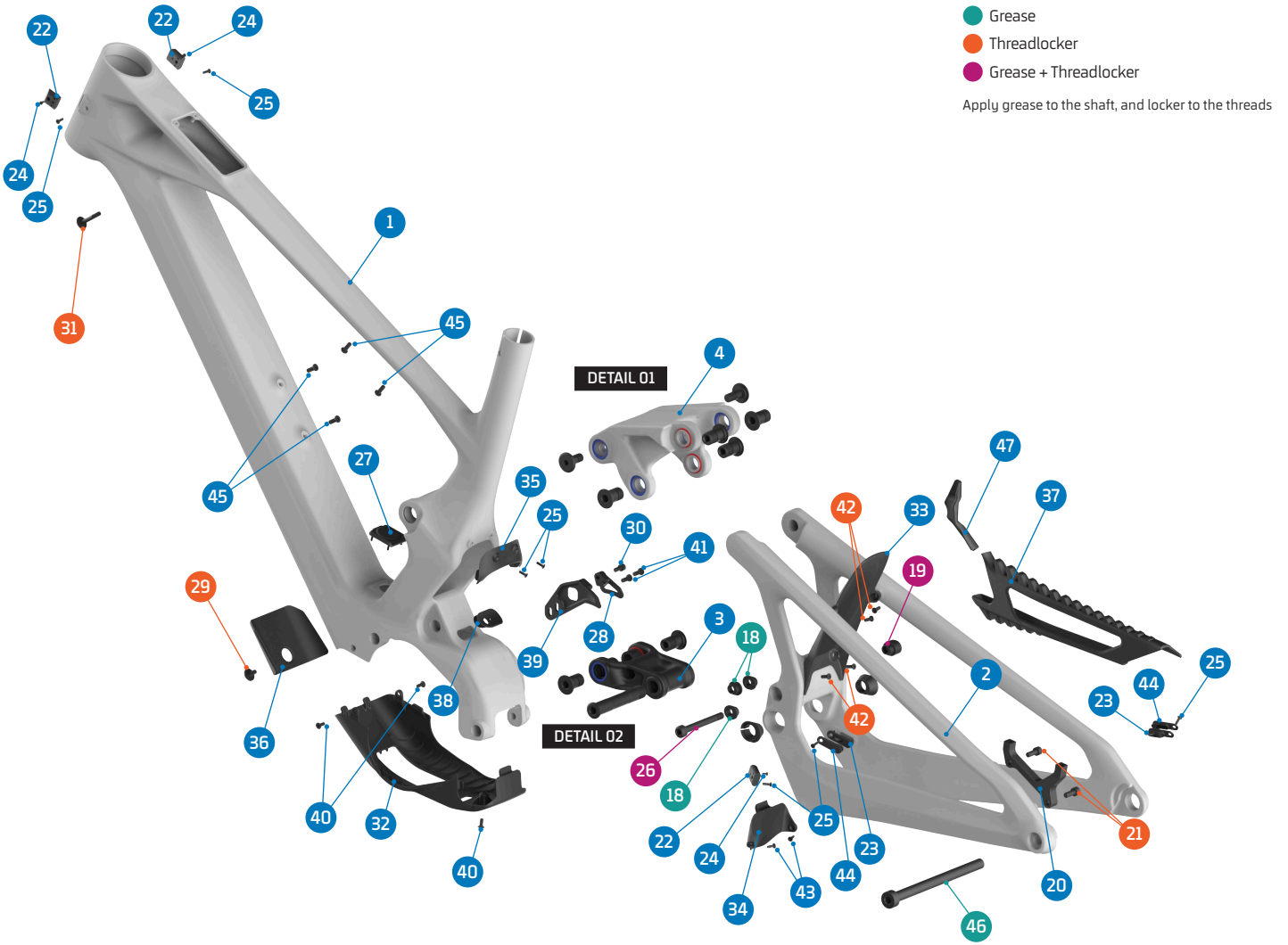

ITEM No.	DESCRIPTION	QTY.	PART NUMBER	TORQUE
1	FRAME	1		
2	REAR TRIANGLE	1		
3	LOWER LINK	1	099.26038	
4	UPPER LINK	1	Refer to B2B web for color options	
5	BEARING, 24x15x7 (3802-2RS)	10	SET 1 / 099.00113	
6	PIVOT WASHER	6	SET 3 & 4	
7	PIVOT SEAL, INTERNAL	8	SET 2, 3, 4 & 8	
8	PIVOT SEAL, EXTERNAL	10	SET 2, 3, 4 & 8	
9	PIVOT AXLE, M15	6	SET 3 & 4	35Nm / 20Nm
10	C-RING	8	SET 2, 3 & 4	
11	SPACER, 38L	1	SET 4	
12	SPACER, LOWER	2	SET 4	
13	PIVOT CHIP, LEFT	1	SET 4 & 099.26049	
14	PIVOT CHIP, RIGHT	1	SET 4 & 099.26050	
15	PIVOT AXLE, 81L	1	SET 4	17Nm
16	SPACER, 10x17x6	2	SET 2	
17	SHOCK BOLT	2	SET 2	8Nm
18	SHOCK FLIP CHIP LEFT	3	099.26044	
19	SHOCK FLIP CHIP RIGHT	1	099.26045	
20	DISC MOUNT	1	SET 6	
21	SCREW BOLT, M6x15	2	SET 6	12Nm
22	CABLE GUIDE	3	SET 7	
23	CABLE GUIDE	2	099.26046	
24	SCREW BOLT, M2,5x5	3	SET 7	1Nm

ITEM No.	DESCRIPTION	QTY.	PART NUMBER	TORQUE
25	SCREW BOLT, M3x10	7	SET 7 & 099.20068	1Nm
26	SHOCK BOLT, 70L	1	SET 2 & 099.26051	10Nm
27	CHARGE PORT COVER	1	099.26052	
28	CHAIN GUIDE OUTER	1	SET 5	
29	SCREW BOLT, M5x10	1	SET 9	5Nm
30	SCREW BOLT, M5x8	1	SET 9	2Nm
31	SCREW BOLT, M5x30	1	SET 9	5Nm
32	MOTOR COVER	1	099.26054	
33	TYRE FENDER	1	099.26055	
34	YOKE FENDER	1	099.26056	
35	FRONT FENDER	1	099.26057	
36	DOWN TUBE PROTECTOR	1	099.20058	
37	CHAINSTAY PROTECTOR	1	099.26059	
38	RUBBER CABLE PROTECTOR	1	099.26060	
39	CHAIN GUIDE BASE PLATE	1	SET 5	
40	SCREW BOLT, M4x10	3	099.26061	2Nm
41	SCREW BOLT, M5x12	2	SET 5	1,5Nm
42	SCREW BOLT, M4x10	4	099.20078	1Nm
43	SCREW BOLT, M3x10	2	099.26063	1Nm
44	CABLE GUIDE, COVER	2	099.26047	
45	SCREW BOLT, M5x8	4		1Nm
46	REAR AXLE	1	112.90027	
47	CHAINSTAY YOKE PROTECTOR	1	099.26109	



DETAIL 01

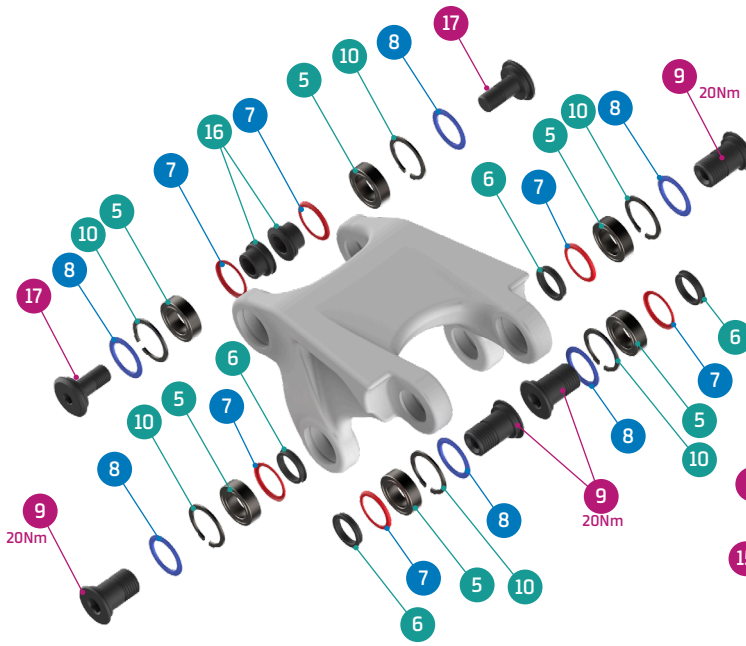

DETAIL 02

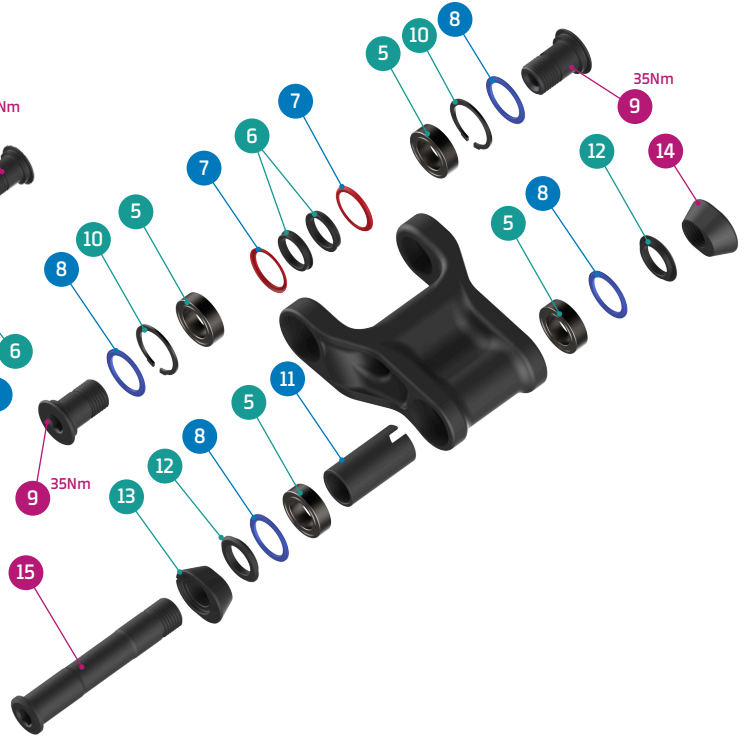

SET 6	SET 7	SET 8	SET 9
DISC ADAPTOR KIT	CABLE GUIDE KIT	SEALS KIT	BATTERY BOLTS KIT

SET 1	SET 2	SET 3	SET 4	SET 5
ZERO BEARING KIT 25	SHOCK HARDWARE KIT 23	UPPER LINK KIT 34	LOWER LINK KIT 38	CHAIN GUIDE PLATE + BOLTS

PART NUMBER	DESCRIPTION	COMPONENTS
099.22100	SET 1: ZERO BEARING KIT 25	BEARING 3802-2RS, 24x15x7 (x10)
099.26201	SET 2: SHOCK HARDWARE KIT 23	PIVOT SEAL INTERNAL (x2) / PIVOT SEAL EXTERNAL (x2) / C-RING (x2) / SPACER, 10x17x6 (x2) / SHOCK BOLT (x2) / SHOCK BOLT, 70 (x1)
099.26300	SET 3: UPPER LINK KIT 34	PIVOT WASHER (x4) / PIVOT SEAL INTERNAL (x4) / PIVOT SEAL EXTERNAL (x4) / PIVOT AXLE, M15 (x4) / C-RING (x4)
099.26400	SET 4: LOWER LINK KIT 38	PIVOT WASHER (x2) / PIVOT SEAL INTERNAL (x2) / PIVOT SEAL EXTERNAL (x4) / PIVOT AXLE, M15 (x2) / C-RING (x2) / SCPACER, 38 (x1) / SCPACER LOWER (x1) / PIVOT CHIP LEFT (x1) / PIVOT CHIP RIGHT (x1) / PIVOT AXLE, 81 (x1)
099.26064	SET 5: CHAIN GUIDE PLATE + BOLTS	CHAIN GUIDE BASE (x1) / CHAIN GUIDE OUTER PLATE (x1) / SCREW BOLT, M5X12 (x2) / SCREW BOLT, M5x10 (x1)
099.25018	SET 6: DISC ADAPTOR KIT	DISC ADAPTOR (x1) / SCREW BOLT (x2)
099.26048	SET 7: CABLE GUIDE KIT	CABLE GUIDE (x1) / SCREW BOTL M2.5X5L (x1) / SCREW BOLT M3X10L (x1)
099.26062	SET 8: SEALS KIT	PIVOT SEAL INTERNAL (x8) / PIVOT SEAL EXTERNAL (x10)
099.26053	SET 9: BATTERY BOLTS KIT	SCREW BOLT, M5x10 (x1) / SCREW BOLT, M5x30 (x1)



21. FAQs

WILL I HAVE THE SAME REAR WHEEL CLEARANCE, SAME ROTOR COMPATIBILITY WHEN RIDING A 29" REAR WHEEL? DO I NEED TO CHANGE ANYTHING ON THE BIKE SETTINGS WHEN DOING SO?

When setting up the bike for a 29" rear wheel you just need to change the position on the lower link flip-chip. Chainstay

length will grow by 7mm compared to the standard mullet wheel set-up, but clearance or brake calliper position don't change. Our bike comes set up for mullet configuration as stock. Before going out riding 29" rear wheel you need to connect the Avinox Ride app and update the wheel set-up configuration.

I PREFER RIDING A FULL 29ER NO MATTER WHAT, WHY IS THE ZENDIT ONLY OFFERED AS A MULLET OPTION AS STOCK MODEL?

Mullet (29" front/27.5" rear) wheel set-up allows for a more playful, nimble feel with more precise handling regardless of

rider skill or bike size. If you prefer a 29" rear wheel, the Zendit's flip chip adjustment allows you to easily change your setup to get the ride feel you want without altering geometry or suspension kinematics, only making chainstay 7mm longer. Because of this, make sure you add 2 extra chain links to the stock chain length of 120 links, growing it to 122 links in total. All Zendit models and sizes are spec'd with SRAM T-Type transmission from stock.

HOW MUCH DOES THE NEW ZENDIT FRAME WEIGH?

The new Stealth Air Carbon frameset on Zendit RR, RR S and XR models is the same and weighs exactly 3.000 grams with hardware included on painted ML size frame (without the rear shock).

WHICH SHOCKS ARE COMPATIBLE WITH THE NEW ZENDIT?

In addition to the Fox Float X and Fox Float X2 shocks we spec on the different Zendit models, the bike is also compatible with Fox DHX coil series, Öhlins TTX air or TTX22 m.2 coil, RockShox coil or air (except the Vivid Air and Vivid Coil not compatible on size S and size M frames). Zendit features metric 205 x 65 mm sized shocks with Trunnion upper mount and bottom 30x8 mm standard hardware. Check before installing any other bigger rear shock because it might not fit, as the piggyback reservoir could hit the main tube at full compression.

DT SWISS HAS RELEASED A NEW RATCHET TECHNOLOGY WITH THEIR DEG HUBS, IS IT AVAILABLE ON THE ZENDIT?

Yes, both Zendit RR S and XR models feature DEG DF anti-pedal kickback technology hubs with -ebike specific- 0- or

10-degree freehub movement. Bikes are factory-fitted with the freehub in the 10-degree free float position as standard.

WHICH KINEMATIC UPDATES OFFERS THE NEW ZENDIT?

Neat became our first model ever featuring evolved Zero Suspension design with its compact design and this latest generation Zendit layout has been updated and improved following the latest performance evolutions seen on other recent generation Mondraker full suspension bikes such as Crafty and Level. 2027 Zendit generation, offers a slightly more progressive rear suspension with 25,7% progression rate, higher leverage ratio, becoming more supple and sensitive off the top, featuring a slightly lower anti-squat and anti-rise curves for a more capable and a better overall performing rear suspension. Rear shock length and stroke are also longer compared to the original one, now at 205x65mm. Recommended sag is around 28% (18mm sag) with maximum recommendation of 33% (21,5mm sag).

WHICH IS THE MAXIMUM FORK TRAVEL ON 2027 ZENDIT MODELS?

Zendit is compatible with forks up to 180 mm travel or 600mm axle to crown although we do not recommend anything different from the stock 170mm fork offerings we spec to keep the perfect geometry and weight balance on all sizes.



21. FAQs

IS IT POSSIBLE TO RUN A LARGER 220MM REAR BRAKE ROTOR ON ZENDIT?

Yes, Zendit is compatible with larger rear brake rotors up to 220mm. This is something we don't really recommend, especially with the latest powerful brakes such as the stock SRAM Maven on the different builds we offer, but yes, it's possible to fit rotors up to 220mm in the rear on all the new Zendit models.

THERE ARE TWO GEOMETRY POSITIONS ON THE ZENDIT, HOW DOES IT WORK?

Same way as on our Crafty Carbon or Level models, Zendit offers 2 geo positions via flip chip. Bike from stock comes in the standard position and by flipping the chip we get to the low position where bottom bracket will drop by 5 mm and head tube angle will change by -0.35° . It is a very simple operation. Undo the shock bottom bolt with a 6mm allen key and flip the 4 aluminium pieces on both sides (2 per side – internal and external), as pictured on the frame. Install the shock bolt again and you are done. You can check all the complete geometry numbers on the Mondraker website.

WHICH IS THE MAXIMUM TYRE WIDTH THAT CAN FIT ON ZENDIT?

Zendit is compatible with tyres up to 66mm wide which translate into 27.5" or 29" x 2.6" tires. It is recommended to measure the tire before installing it as the real tyre width might be different from what it says, depending on the manufacturer.

WOULD IT BE POSSIBLE TO ADD A BATTERY EXTENDER ON THE ZENDIT TO INCREASE THE RANGE AND RIDE LONGER?

No, the Zendit with Avinox motor features only the internal 800Wh battery and no range extender is available.

CAN I CARRY A WATER BOTTLE?

Yes, you can. There are 2 possible locations for a water bottle cage in the main frame. The standard position (as on any other bike) and below the top tube.

NEW CABLE ROUTING IS EXTERNAL THROUGH THE HEADTUBE, IS IT POSSIBLE TO RUN THE CABLES INTERNALLY THROUGH THE HEADSET?

Yes, you can. The new headset upper cup is ready to route the cables through it and run a complete internal guiding if you

prefer it this way.

IS IT POSSIBLE TO DISASSEMBLE THE INTERNAL BATTERY?

It is possible by removing the motor first. This operation must be performed by a qualified mechanic at an authorized dealer but at Mondraker we do not recommend disassembling the battery in any case.

HOW LONG DOES IT TAKE TO FULLY CHARGE THE BATTERY?

With the fast charger (12A - GaN - 508W) that comes as stock on the XR model you can charge from 0 to 75% in just 1h 30 minutes and from 0 to 100% in just 2h 25 minutes. The RR S and RR models feature Avinox's standard 4A - 168W charger with which you can charge from 0 to 75% in 4h 28 min and from 0 to 100% in 5h 10 min.



21. FAQs

SRAM'S LATEST GENERATION T-TYPE REAR DERAILLEURS CAN WORK DIRECTLY PLUGGED INTO THE BIKE'S MAIN BATTERY WITH THE POWERCORD. IS IT POSSIBLE TO DO SO HERE WITH THE LATEST ZENDIT MODELS?

Yes, in fact this feature comes as stock on all Zendit RR, RR S and XR models. Thanks to this configuration, the SmoothShift function is available and will appear on your Avinox display as an option to activate or deactivate. When SmoothShift is switched on and a gear shift is detected, the motor will automatically rotate the chainring independently from the cranks, allowing you to change to a higher or lower gear while coasting (without pedalling and without moving the cranks). To protect the drivetrain, the system uses multi-sensor fusion to momentarily reduce motor torque during these shifts, ensuring the chain moves smoothly between cogs. This precision prevents excessive wear and tear by matching the motor's rotation to the wheel speed for the duration of the shift, with full torque being instantly restored the moment the gear change is complete.

ZENDIT FEATURES A SRAM T-TYPE TRANSMISSION, WOULD IT BE POSSIBLE TO RUN A SHIMANO DRIVETRAIN AND REAR DERAILLEUR?

Yes, totally. Just consider that you would need an additional UDH derailleur hanger for the Shimano rear derailleur.

WHICH IS THE MAXIMUM ASSISTANCE I CAN GET FROM THE ZENDIT'S AVINOX M2S MOTOR?

Max assistance is 800% with 150Nm and 1.300W in Boost mode.

IS IT POSSIBLE TO CUSTOMISE THE ASSISTANCE MODES ON THE ZENDIT?

Yes, you can customise Zendit's Avinox M2S assistance modes the same way as with other motor systems. You can do it directly on the display on the bike or through the Avinox Ride app on your mobile phone. It is a very straightforward

operation, and you'll be able to customise every riding parameter to your desired preference very easily. On the Avinox website <https://www.avinox-ebike.com/> or the Avinox Ride app you will find all information related to motor customisation and set up of the different assistance modes Auto, Eco, Trail, Turbo and Boost.

HOW LONG CAN I RIDE WITH THE NEW ZENDIT?

This is always a tricky question and, as always, it depends on the level of assistance you are using, rider fitness, rider weight and riding conditions. With the stock 800Wh battery, an average rider, with 80 kgs riding weight, can climb around 2.000m elevation gain combining different riding assistance modes and ride as much as 4 hours in AUTO-ECO modes. Again, depending on riding conditions and rider's physical level.

WHICH INFORMATION DOES THE ZENDIT DISPLAY OFFER?

You can find all display and remote manual information following this link <https://www.avinox-ebike.com/>

WHICH TYPE OF MAINTENANCE OR SAFETY CHECKS DO AVINOX M2S MOTOR REQUIRE?

Absolutely none. Nor is it required to lubricate any parts in the drive unit nor disassemble it... all you have to do is take care for it as you do with a traditional mountain bike. However, it is important to mention precautions applicable to any mountain bike: electronic parts and, specifically, the bottom bracket area where the drive unit is located, should never be cleaned with any type of high-pressure cleaning machine. It is not recommended to use high-pressure water jets to clean the cranks axle directly, as the electronic parts of the drive unit can get seriously damaged.



21. FAQs

WHICH BIKE SIZE DO I NEED?

Zendit models are featured in 5 sizes with a ML size in between sizes Medium and Large. Compared with the 4-sizes option we offer in different Mondraker models, the new Small and Medium sizes are slightly smaller compared to the previous Small and Medium sizes and the new Large and Extra Large are slightly larger as well. Check the geometry charts for further information and all the details.

Here's a glimpse of the recommended sizing for a given rider height.

<165 cm	165-170 cm	170-175 cm	175-180 cm	180-185 cm	185-190 cm	190-195 cm	>195 cm
S		M/L				XL	
	M			L			



All information and pictures on this document is provided for information purposes only and does not constitute a legal contract between Mondraker and any person or entity. Specifications, geometries or any other technical information published is subject to change without prior notice.

© © All trademarks and models are property of Blue Factory Team, S.L.U. and are protected by current laws and applicable international agreements.

ANLEITUNGEN UND DOKUMENTE





SICHERHEITS- UND ALLGEMEINE HINWEISE

Bitte beachten Sie, dass in diesem technischen Leitfaden die folgenden drei Symbole erscheinen können. Sie weisen jeweils auf die folgenden Vorsichtsmaßnahmen hin:

WARNUNG:

Die Nichtbeachtung dieser Hinweise oder die Durchführung unsicherer Praktiken kann zu schweren Verletzungen oder sogar zum Tod führen. Die Arbeiten sind technisch anspruchsvoll und können bei fehlerhafter Ausführung zu Schäden am Fahrrad oder zum Erlöschen der Garantie führen.

VORSICHT:

Die Nichtbeachtung dieser Hinweise oder die Durchführung unsicherer Praktiken kann zu leichten Verletzungen führen. Die Arbeiten sind technisch anspruchsvoll und können bei fehlerhafter Ausführung zu Schäden am Fahrrad oder zum Erlöschen der Garantie führen.

INFORMATION

Informationen, die für eine ordnungsgemäße Ausführung der Arbeit wichtig sind und daher mögliche Schäden an Ihrem Fahrrad oder den Verlust der Garantie verhindern. Hier besteht jedoch kein Risiko für Personen.

WICHTIGE HINWEISE

- Die Verwendung von nicht originalen Ersatzteilen kann zu Schäden, Fehlfunktionen und Unfällen mit schweren Folgen führen.
- Bitte beachten Sie, dass für einige der in diesem Handbuch beschriebenen Arbeitsschritte Kenntnisse erforderlich sind, die über die Kompetenz eines durchschnittlichen Fahrradfahrers hinausgehen. Falls Sie nicht qualifiziert sind, diese Schritte auszuführen, bringen Sie Ihr Fahrrad zur Wartung und zum Austauschen von Bauteilen zu einem von Mondraker autorisierten technischen Kundendienst. Der falsche Einbau von Ersatzteilen kann zu Fehlfunktionen, Unfällen, Verletzungen und zum Erlöschen der Garantie führen.

REINIGUNG UND PFLEGE

- Nach einem Ausbau der Teile wird empfohlen, die wiederzuverwendenden Komponenten zu reinigen, zu fetten und (falls erforderlich) mit Schraubensicherung zu versehen.

SYMBOL-LEGENDE



Mittelfeste Schraubensicherung. Loctite 243.



Synthetische Montagepaste.



Spezielle Carbon Montagepaste.



1. GEOMETRIE

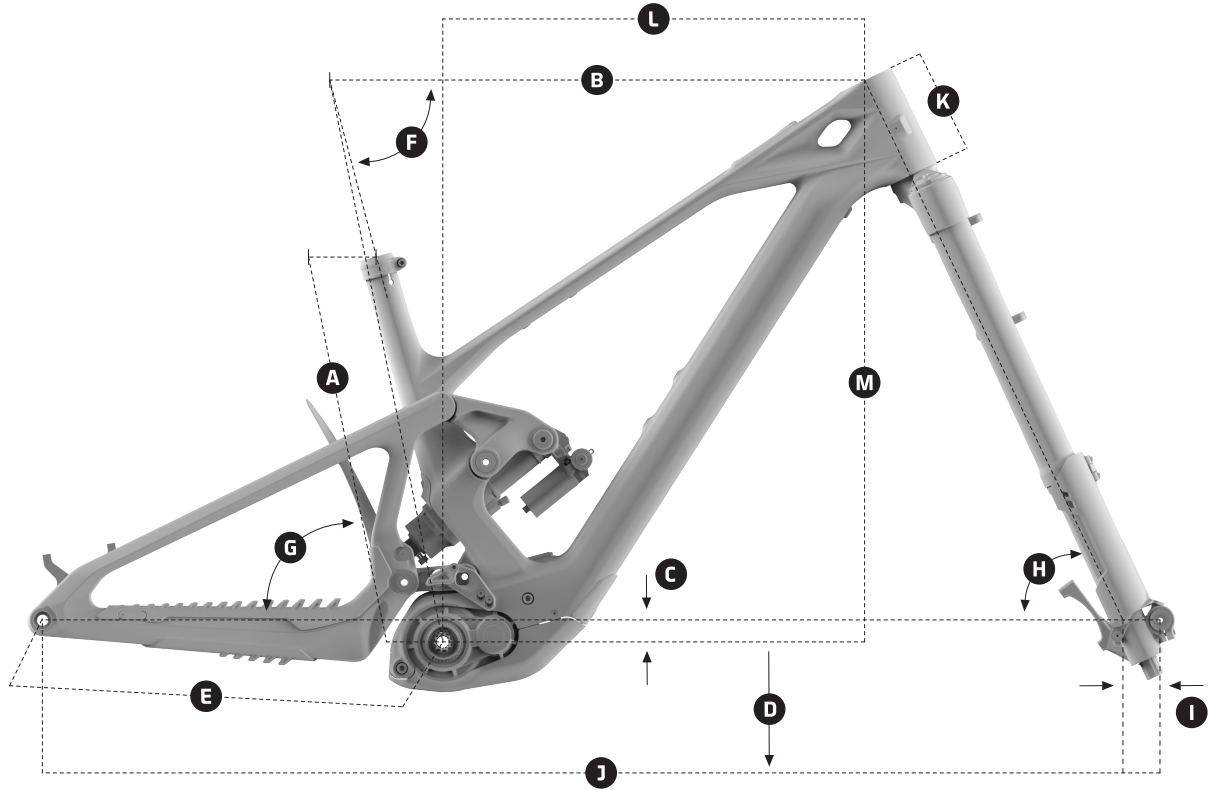

ZENDIT (FLIP-CHIP STANDARDPOSITION)

	RAHMENHÖHE	S	M	ML	L	XL
A	Sitzrohrlänge	380 mm	410 mm	435 mm	460 mm	490 mm
B	Oberrohrlänge	586 mm	606 mm	628 mm	650 mm	672 mm
C	Innenlagerabsenkung	6 mm	6 mm	6 mm	6 mm	6 mm
D	Innenlagerhöhe	345 mm	345 mm	345 mm	345 mm	345 mm
E	Kettenstrebenlänge	450 mm	450 mm	450 mm	455 mm	455 mm
F	Sitzwinkel	73,5°	73,5°	73,5°	73,5°	73,5°
G	Sitzwinkel (effektiv)	77,0°	77,0°	77,0°	77,0°	77,0°
H	Lenkwinkel	63,5°	63,5°	63,5°	63,5°	63,5°
I	Gabel Offset	44 mm	44 mm	44 mm	44 mm	44 mm
J	Radstand	1241 mm	1261 mm	1286 mm	1315 mm	1339 mm
K	Steuerröhrlänge	110 mm	110 mm	120 mm	130 mm	140 mm
L	Reach	440 mm	460 mm	480 mm	500 mm	520 mm
M	Stack	631 mm	631 mm	640 mm	649 mm	658 mm

*Die Kettenstrebenlänge erhöht sich um 7 mm, wenn ein 29"-Hinterrad montiert wird.



1. GEOMETRIE

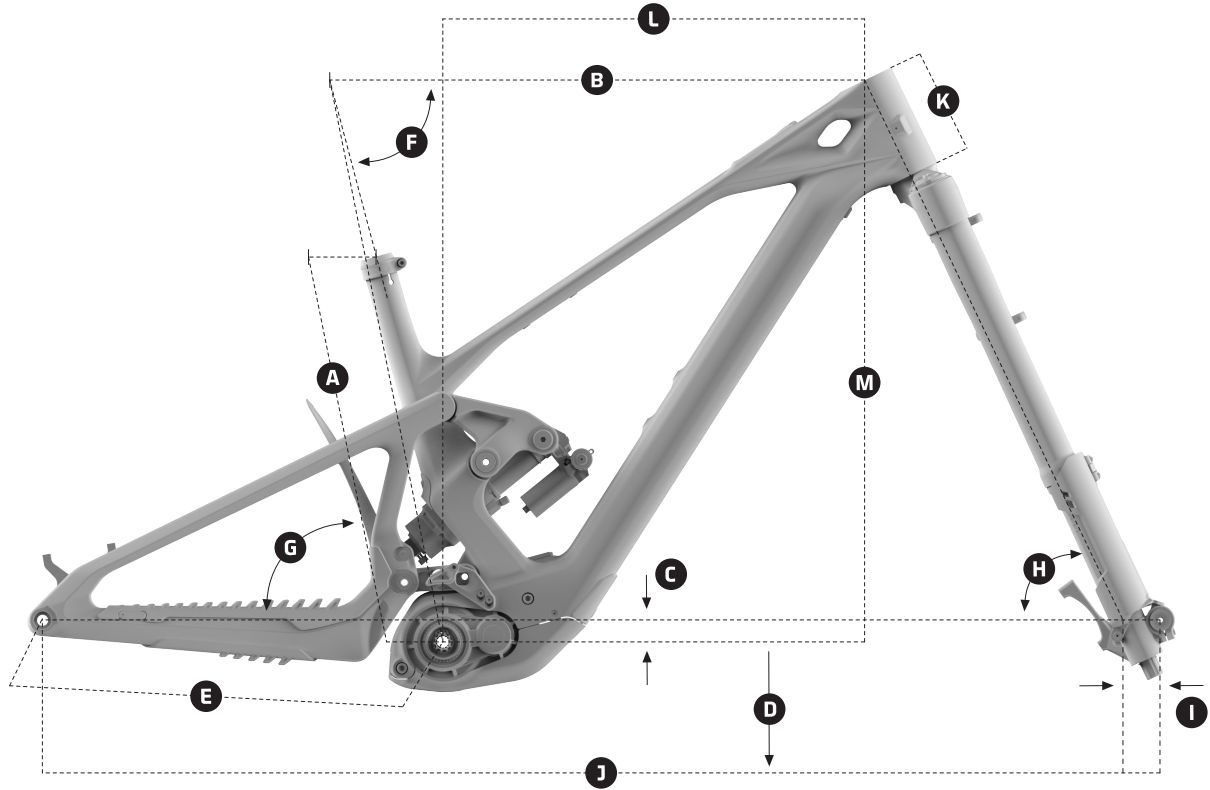

ZENDIT (FLIP-CHIP POSITION LOW)

	RAHMENHÖHE	S	M	ML	L	XL
A	Sitzrohrlänge	380 mm	410 mm	435 mm	460 mm	490 mm
B	Oberrohrlänge	586 mm	606 mm	629 mm	651 mm	673 mm
C	Innenlagerabsenkung	11 mm	11 mm	11 mm	11 mm	11 mm
D	Innenlagerhöhe	340 mm	340 mm	340 mm	340 mm	340 mm
E	Kettenstrebenlänge	451 mm	451 mm	451 mm	456 mm	456 mm
F	Sitzwinkel	73,15°	73,15°	73,15°	73,15°	73,15°
G	Sitzwinkel (effektiv)	76,65°	76,65°	76,65°	76,65°	76,65°
H	Lenkwinkel	63,15°	63,15°	63,15°	63,15°	63,15°
I	Gabel Offset	44 mm	44 mm	44 mm	44 mm	44 mm
J	Radstand	1242 mm	1262 mm	1287 mm	1316 mm	1340 mm
K	Steuerrohrlänge	110 mm	110 mm	120 mm	130 mm	140 mm
L	Reach	436 mm	456 mm	476 mm	496 mm	516 mm
M	Stack	633 mm	634 mm	643 mm	652 mm	661 mm

*Die Kettenstrebenlänge erhöht sich um 7 mm, wenn ein 29"-Hinterrad montiert wird.



2. RAHMENSPEZIFIKATIONEN

RAHMENGRÖSSEN	S / M / ML / L / XL
VORDERRADGRÖSSE	29"
NABE VORN	110mm x 20mm (BOOST)
HINTERRADGRÖSSE	27.5" / 29"
NABE HINTEN	148mm x 12mm (BOOST)
HINTERACHSE	12X148 P1.0 L180
ANZAHL WASSERFLASCHEN	Unterrohr für Flaschenhalter, Oberrohr für Zubehör.
MOTOR	Avinox
INNENLAGER	Avinox
AKKU	800Wh
POWER RANGE	-
FEDERWEG	165mm
SCHOCKABSORBER	205 x 65mm TRUNNION, 30 x 8mm
FEDERGABEL	170mm
DURCHMESSER SATTELSTÜTZE	31.6mm / 36.9mm
KETTENLINIE	55mm
STEUERSTAZ	ZS56 / ZS56, 1-1/8", 1.5"
KETTENBLATT MAX	36T
BREMSE HINTEN	POST MOUNT, DIRECT 220mm max
MAXIMAL KOMPATIBLE REIFENGRÖSSE	29" x 2.6" (66-622)

3. EINSTECKTIEFE DER SATTELSTÜTZE

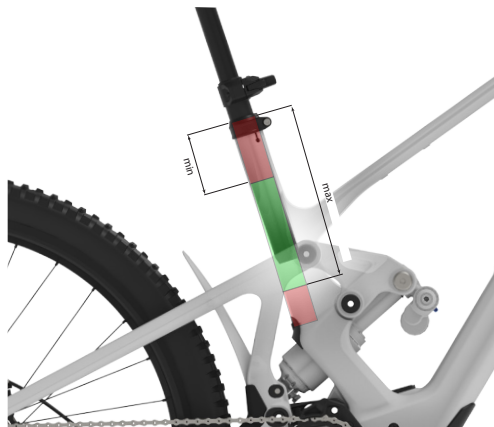

RAHMENGRÖSSE	MIN. (mm)	MAX. (mm)
XL	100	300
L	100	270
ML	100	244
M	100	220
S	100	190



4. BAUTEILE ANTRIEB

4.1. KETTENFÜHRUNG

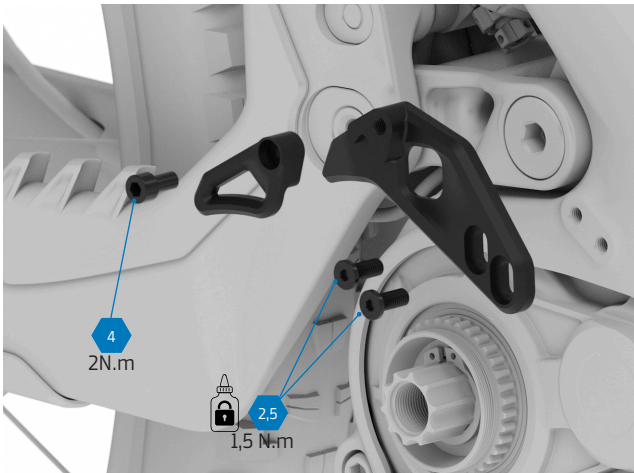

4.2. KETTENBLATT

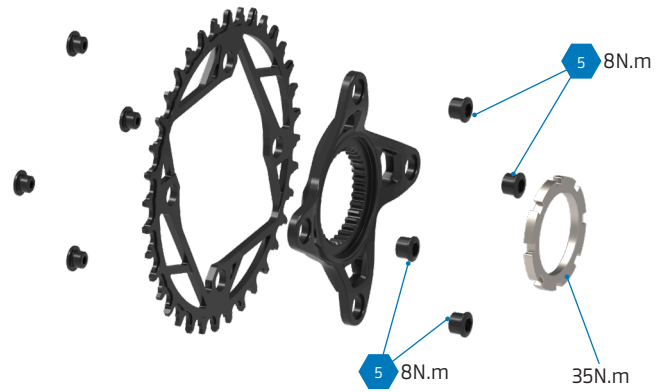

5. MOTORABDECKUNG

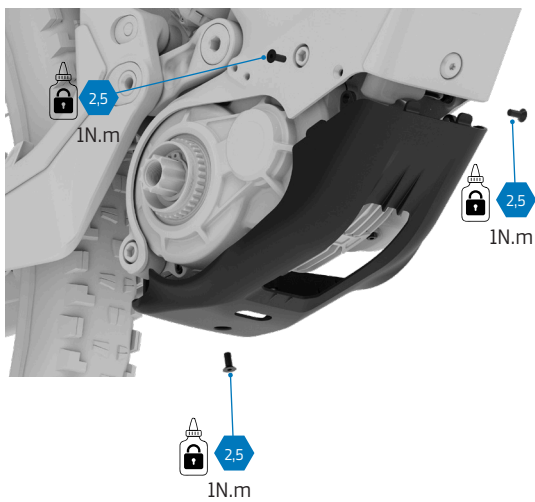



6. MOTOR

6.1. MONTAGE DES MOTORS AM RAHMEN

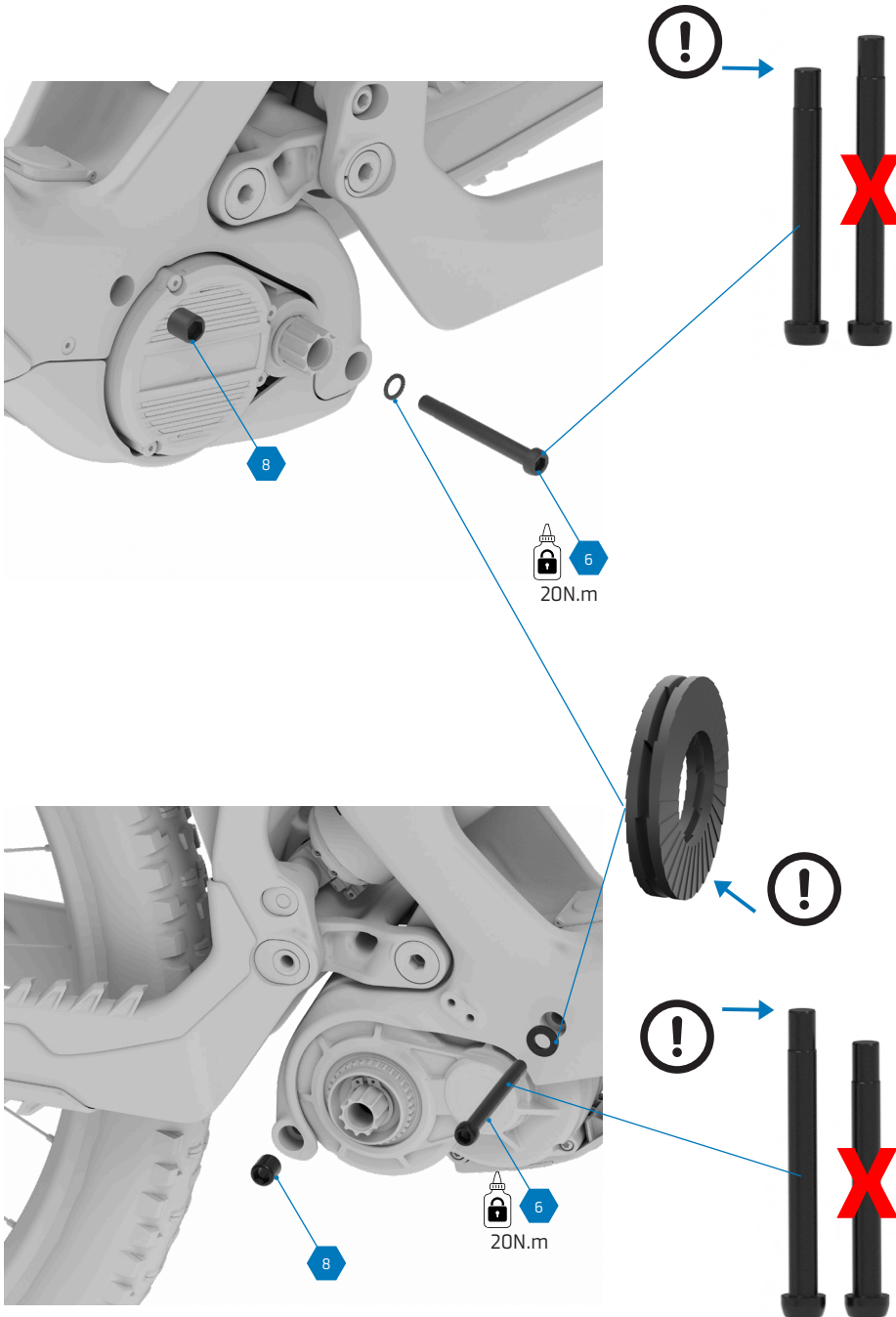

6. MOTOR

6.2. ABSTANDSHALTER ZWISCHEN RAHMEN UND MOTOR

Dieser Schritt ist nur erforderlich, wenn der Motor oder der Rahmen durch einen neuen ersetzt wird. Die bei Mondraker montierten Motoren und Rahmen sind bereits mit den richtigen Abstandshaltern ausgestattet.

Für die Durchführung dieser Aufgabe ist ein spezielles AVINOX-Werkzeug erforderlich.

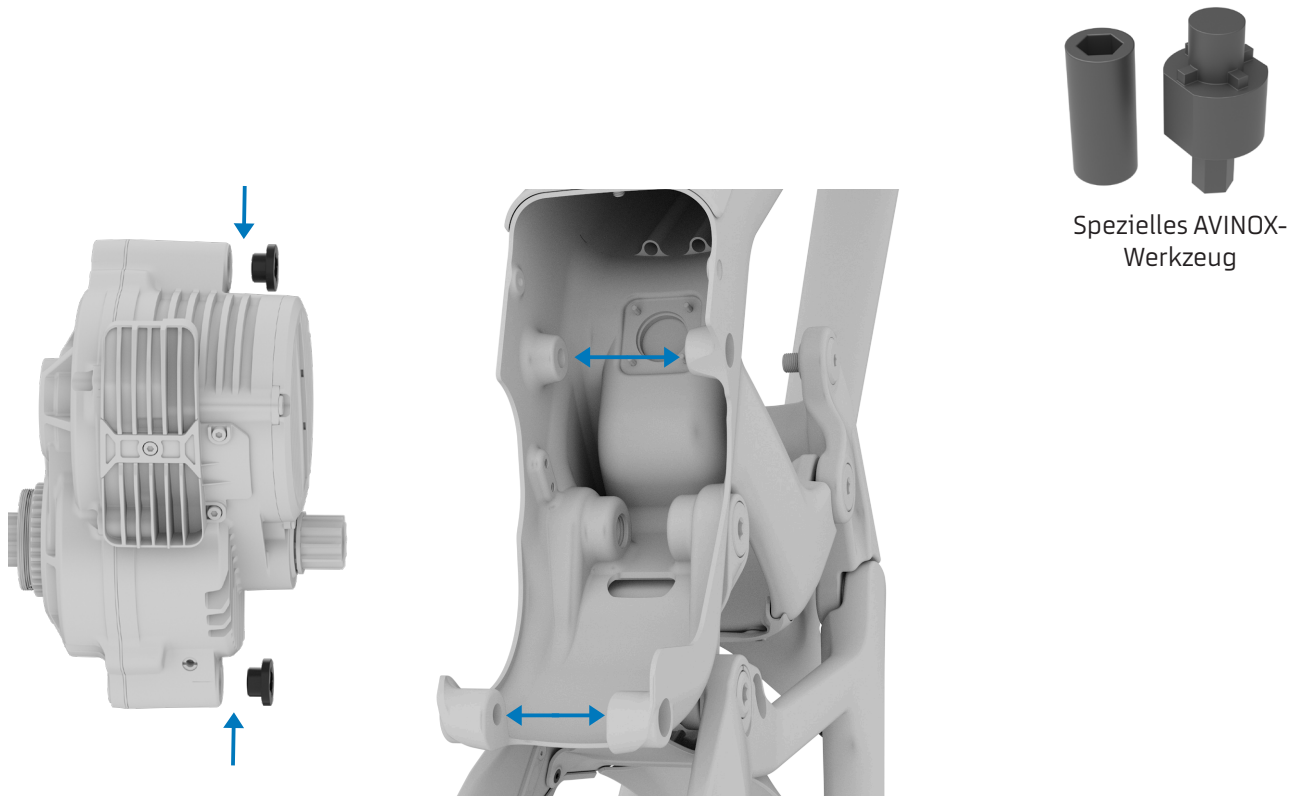

Im Falle eines Austauschs des Rahmens oder des Motors muss der Abstand zwischen den Carbon-Auflageflächen der Motoraufnahme mit einem Messschieber gemessen werden. Abhängig von diesem Maß müssen die entsprechenden Distanzscheiben oder Abstandshalter gemäß den Werten in der Tabelle zwischen Motor und Schraube eingesetzt werden. Es ist zwingend erforderlich, die Maße sowohl an der vorderen als auch an der hinteren Befestigung zu überprüfen, da diese variieren können und somit eine unterschiedliche Anzahl von Abstandshaltern erfordern. Das abschließende Festziehen der Schrauben muss mit dem speziellen AVINOX-Werkzeug mit einem Anzugsdrehmoment von **5 Nm** erfolgen.

A = X - 56.7mm (Vorderer Aufhängepunkt) A = Y - 47.1mm (Hinterer Aufhängepunkt)

Abstand zwischen Rahmen und Motor	Anzahl der Unterlegscheiben am Montagepunkt
$A < 0.25\text{mm}$	0
$0.25\text{mm} \leq A < 0.50\text{mm}$	0
$0.50\text{mm} \leq A < 0.75\text{mm}$	2
$0.75\text{mm} \leq A < 1.00\text{mm}$	3
$A = 1.00\text{mm}$	4
$A > 1.00\text{mm}$	Rahmentoleranz ist abnormal: Die Antriebseinheit kann nicht installiert werden.



7. LADEANSCHLUSS

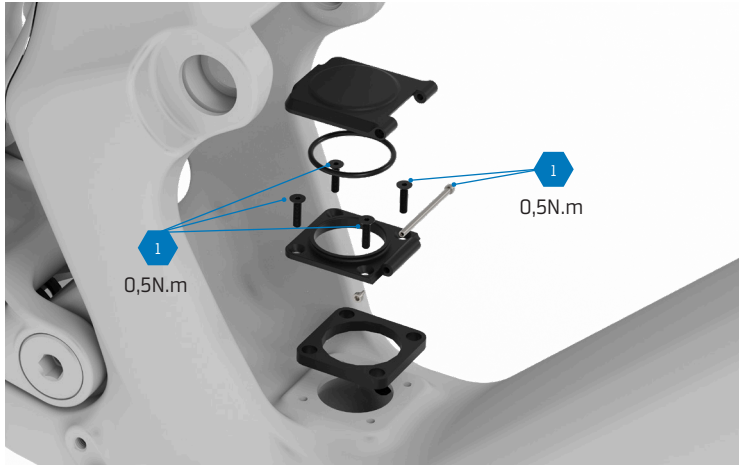

8. INTERNE KABEL- UND ZUGVERLEGUNG

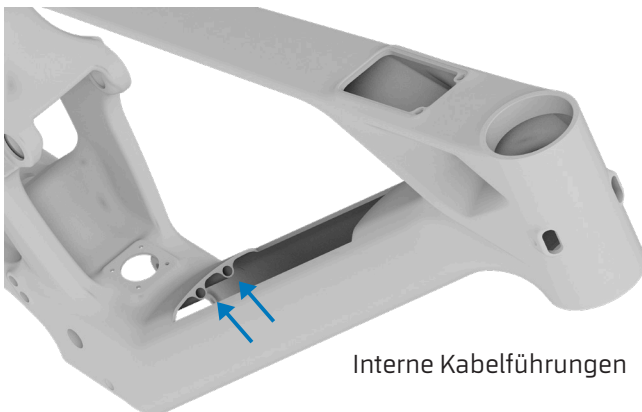
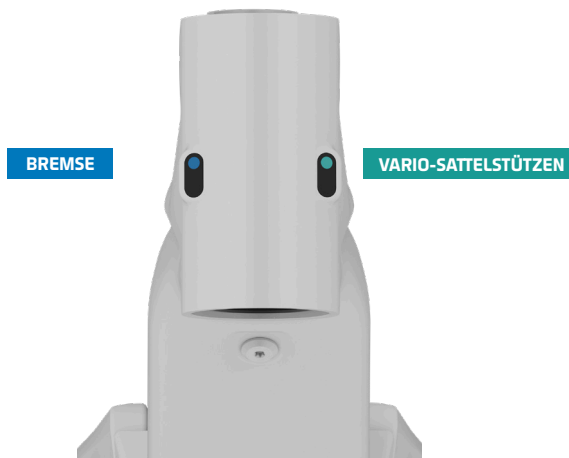



8. INTERNE KABEL- UND ZUGVERLEGUNG

8.1. KABELINGÄNGE

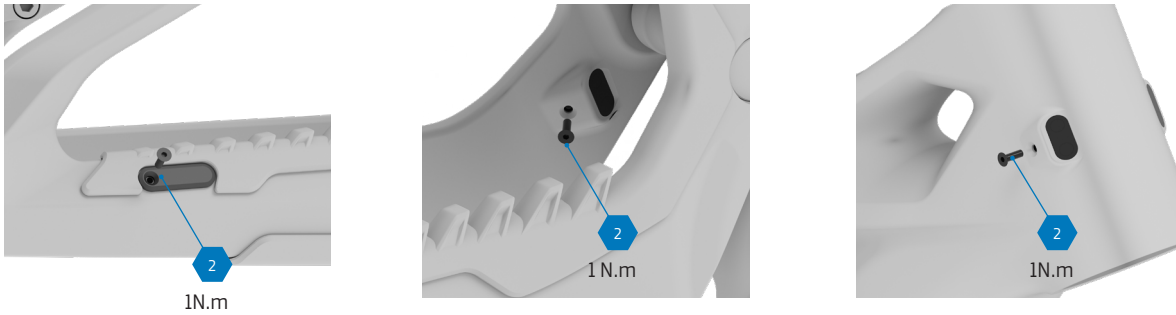

8.2. GESCHWINDIGKEITSSENSOR-EINGANG

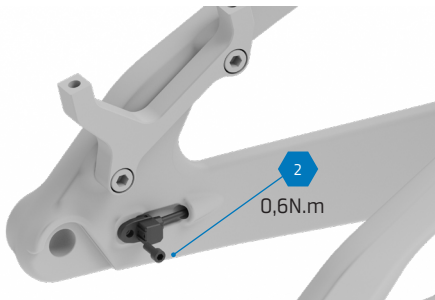

9. SCHRAUBEN DES AKKUS

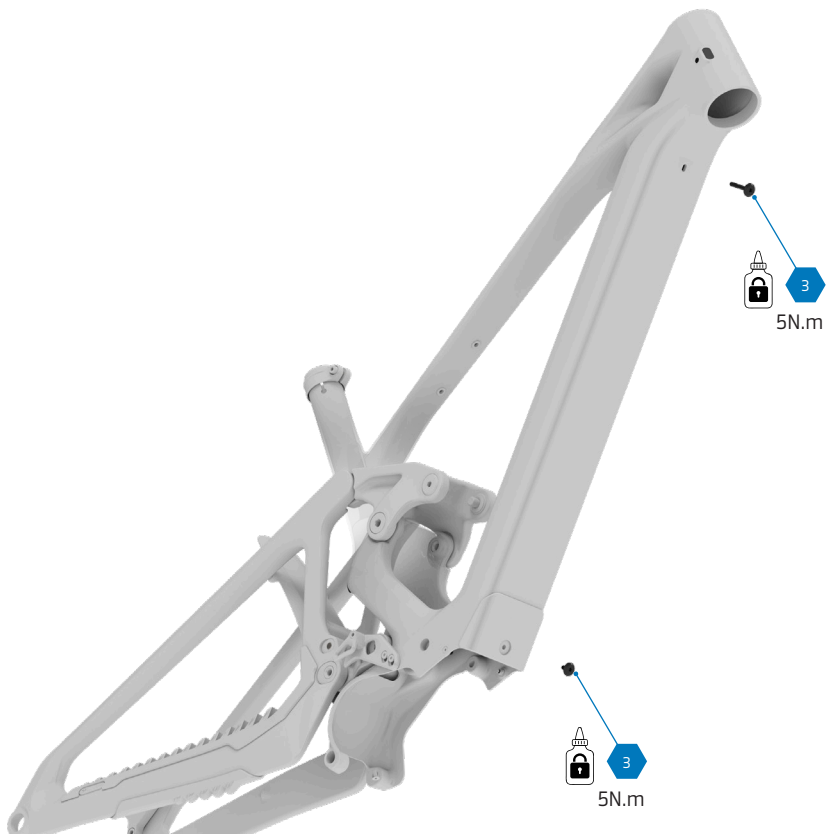



10. DISPLAY



11. KABELLOSER CONTROLLER

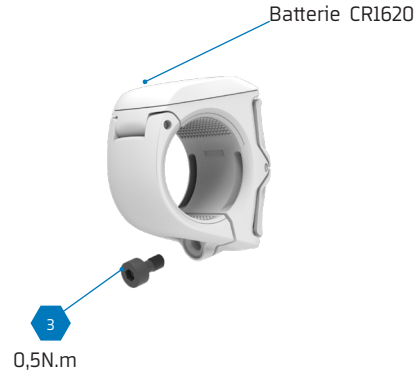

12. SPRITZSCHUTZ

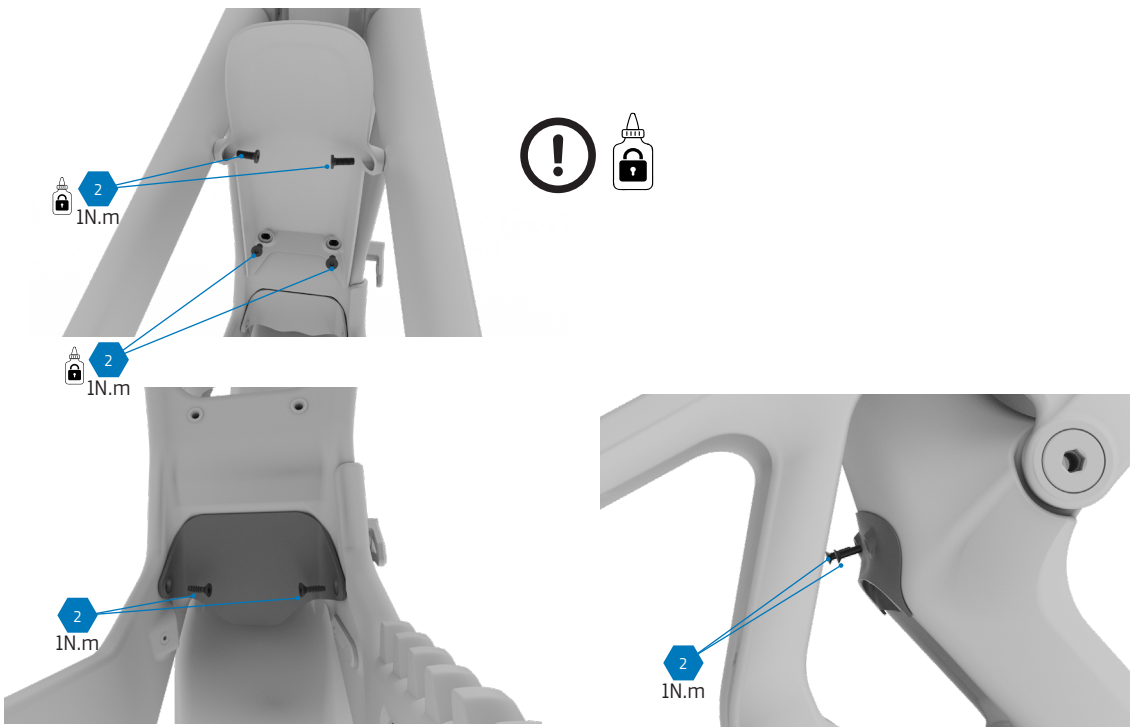

15. SATTELSTÜTZENKLEMME



Es wird empfohlen
zwischen Rahmen und
Sattelstütze spezielle
Carbon-Montagepaste
aufzutragen

16. MONTAGEANLEITUNG FÜR OBERE WIPPE



Verwenden Sie Loctite 243 für das Gewinde.



Pro-Tipp: Anstatt die Schraubensicherung auf die Schraube aufzutragen, können Sie diese auch direkt in das Innengewinde des Fahrradrahmens geben. So vermeiden Sie, dass andere Komponenten beim Einsetzen der Schraube mit der Schraubensicherung verunreinigt werden.

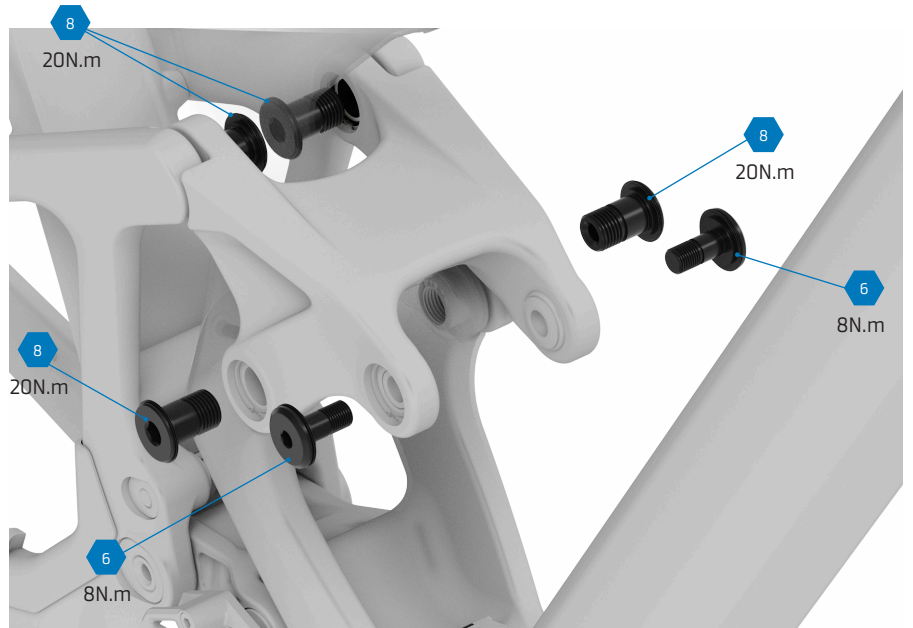
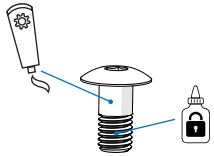

Tragen Sie auf den Schaft der Hauptschrauben Fett auf und auf das Gewinde Loctite 243

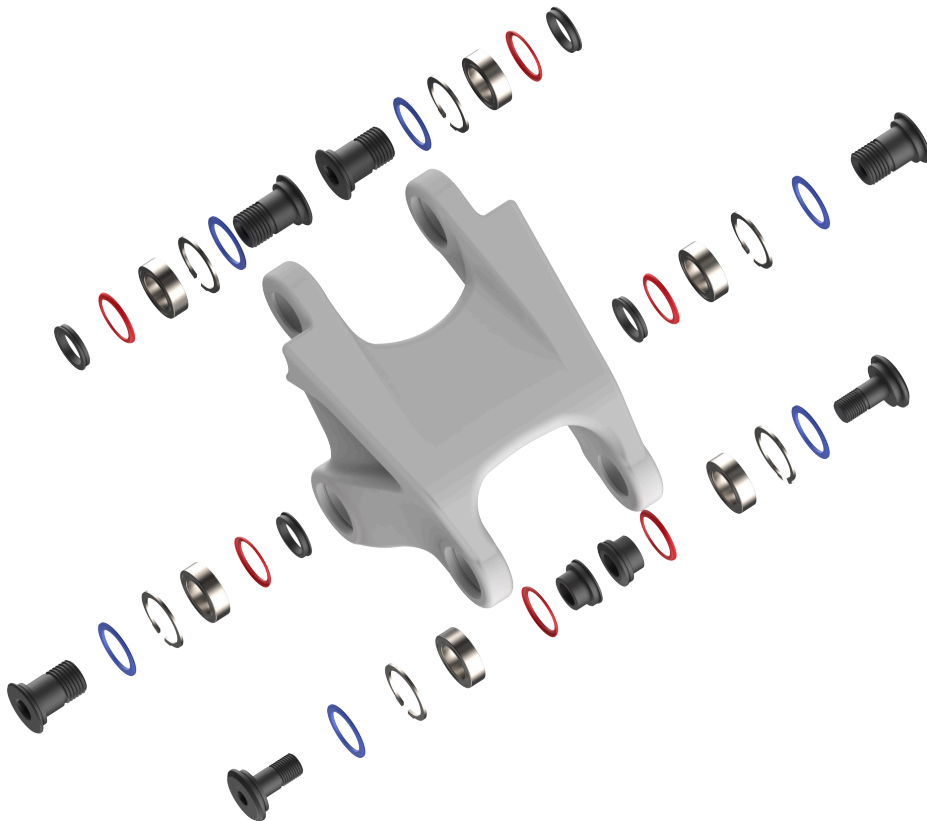

Achten Sie besonders auf die Position der Gummidichtungen.



Tragen Sie Fett auf die Reibungsflächen auf, vermeiden Sie jedoch eine Verunreinigung der Gewindebereiche.

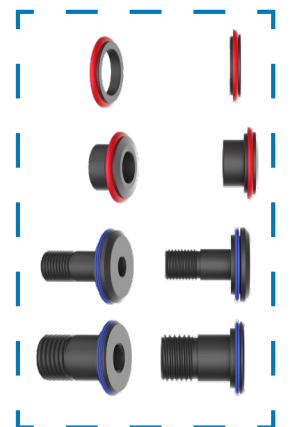



17. MONTAGEANLEITUNG FÜR UNTERE WIPPE

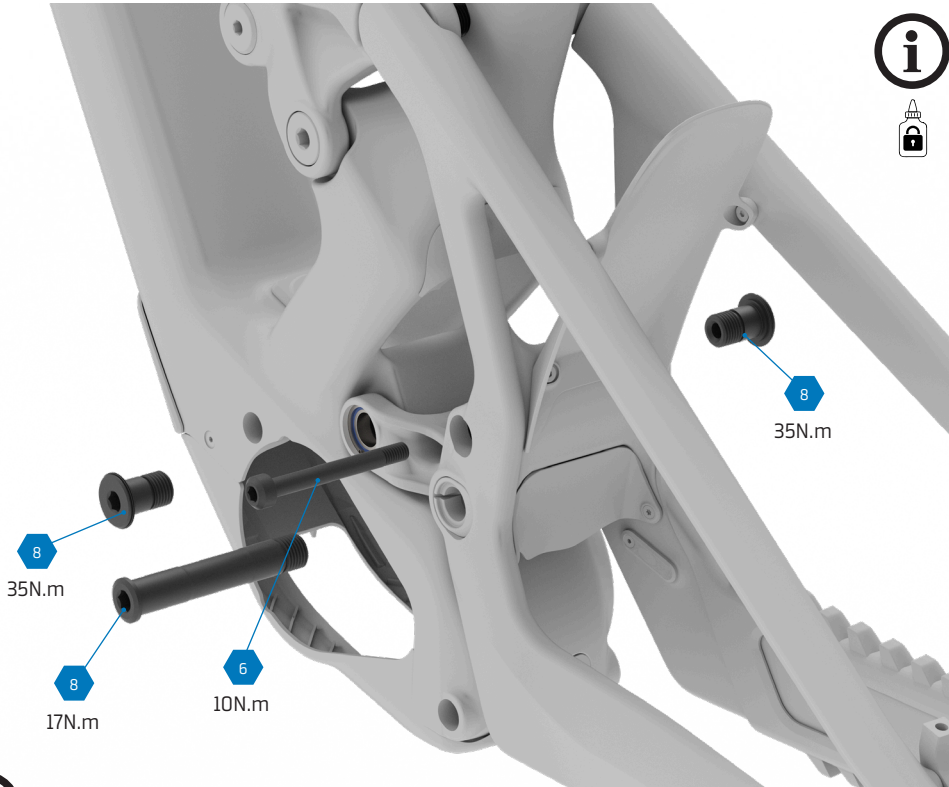

Verwenden Sie Loctite 243 für das Gewinde.



Pro-Tipp: Anstatt die Schraubensicherung auf die Schraube aufzutragen, können Sie diese auch direkt in das Innengewinde des Fahrradrahmens geben. So vermeiden Sie, dass andere Komponenten beim Einsetzen der Schraube mit der Schraubensicherung verunreinigt werden.

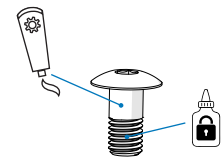

Tragen Sie auf den Schaft der Hauptschrauben Fett auf und auf das Gewinde Loctite 243

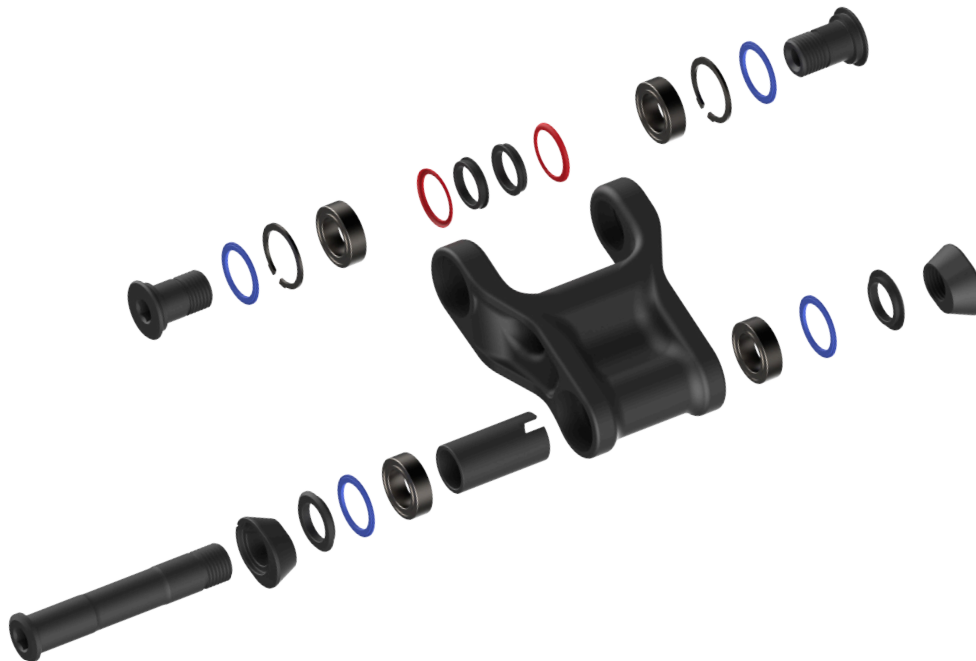

Achten Sie besonders auf die Position der Gummidichtungen.



Tragen Sie Fett auf die Reibflächen auf, vermeiden Sie jedoch eine Verunreinigung der Gewindebereiche.

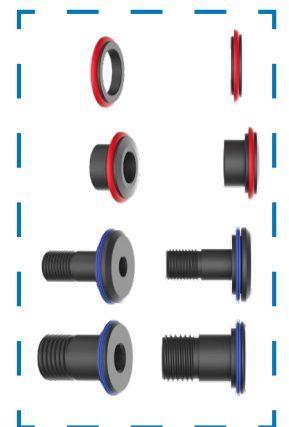



18. FLIP-CHIP

18.1 FLIP-CHIP FÜR LAUFRADGRÖSSENWECHSEL 27.5"-29"

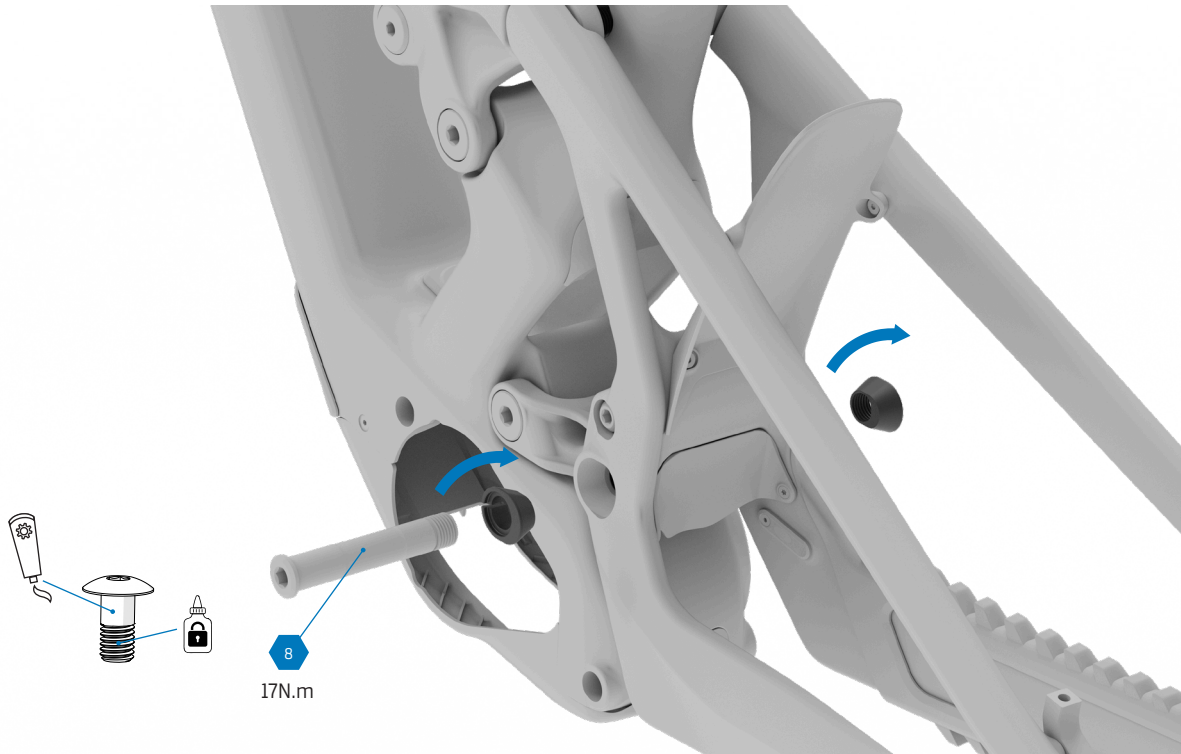

- ⚠ Tragen Sie auf den Schaft der Hauptschrauben Fett auf und auf das Gewinde Loctite 243.
- ⚠ Tragen Sie Fett auf die Reibungsflächen auf, vermeiden Sie jedoch eine Verunreinigung der Gewindebereiche.
- ⚠ Beim Wechsel von 27,5"- auf 29"-Räder müssen 2 zusätzliche Kettenglieder hinzugefügt werden. Bei 27,5" sind es 120 Glieder, bei 29" sind es 122 Glieder. Verbinden Sie zudem die Avinox Ride App und aktualisieren Sie die Wheel Set-up-Einstellungen.

18.2 FLIP-CHIP FÜR KINEMATIKWECHSEL STD - LOW

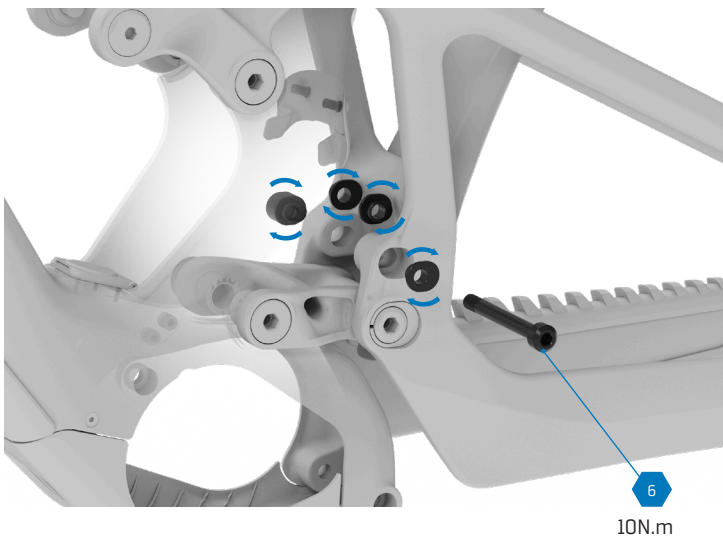

Der Flip-Chip für den Kinematikwechsel besteht aus 4 Teilen: 2 äußeren und 2 inneren.



20. SPARE PARTS
ZENDIT

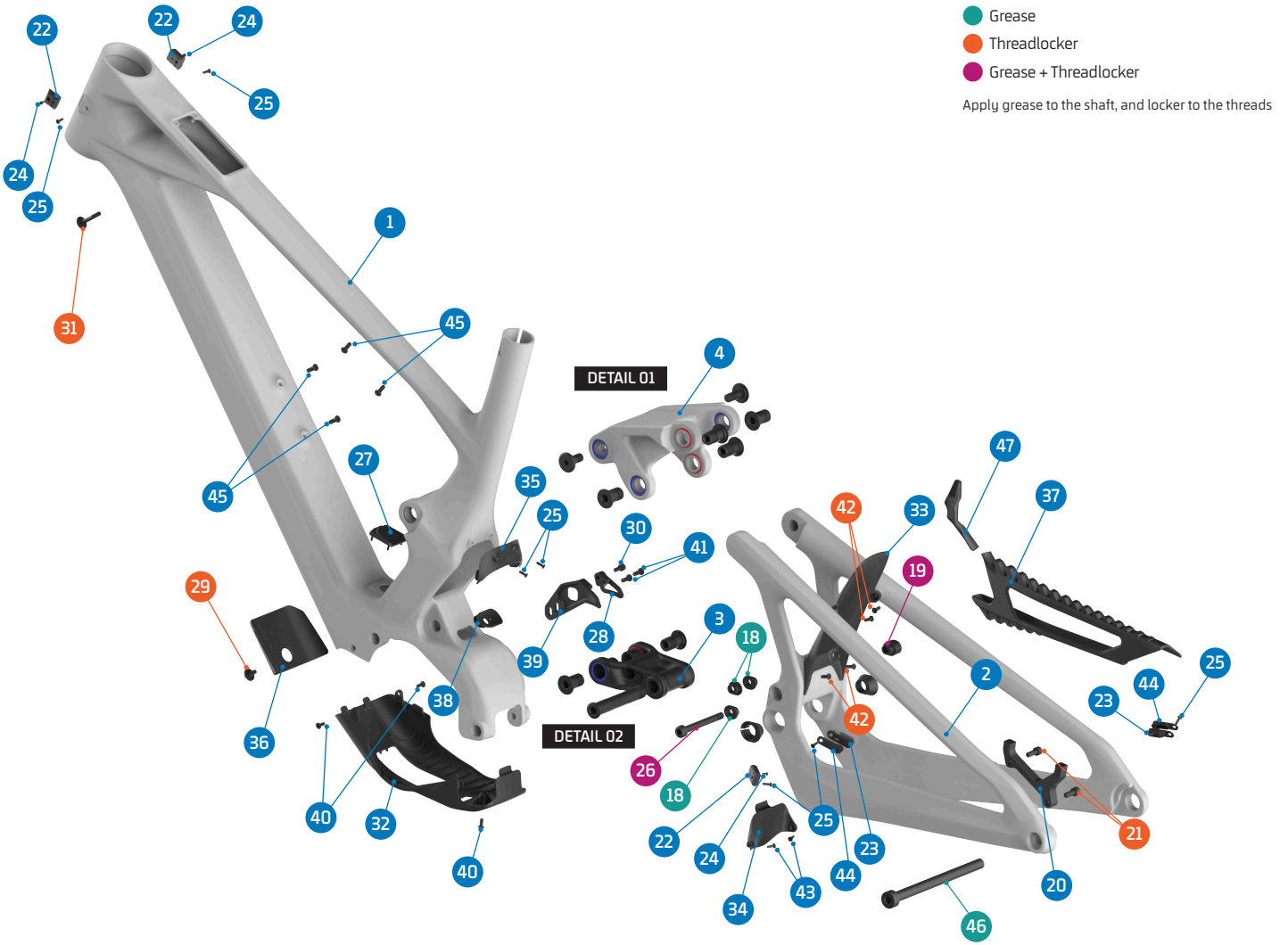

ITEM No.	DESCRIPTION	QTY.	PART NUMBER	TORQUE
1	FRAME	1		
2	REAR TRIANGLE	1		
3	LOWER LINK	1	099.26038	
4	UPPER LINK	1	Refer to B2B web for color options	
5	BEARING, 24x15x7 (3802-2RS)	10	SET 1 / 099.00113	
6	PIVOT WASHER	6	SET 3 & 4	
7	PIVOT SEAL, INTERNAL	8	SET 2, 3, 4 & 8	
8	PIVOT SEAL, EXTERNAL	10	SET 2, 3, 4 & 8	
9	PIVOT AXLE, M15	6	SET 3 & 4	35Nm / 20Nm
10	C-RING	8	SET 2, 3 & 4	
11	SPACER, 38L	1	SET 4	
12	SPACER, LOWER	2	SET 4	
13	PIVOT CHIP, LEFT	1	SET 4 & 099.26049	
14	PIVOT CHIP, RIGHT	1	SET 4 & 099.26050	
15	PIVOT AXLE, 81L	1	SET 4	17Nm
16	SPACER, 10x17x6	2	SET 2	
17	SHOCK BOLT	2	SET 2	8Nm
18	SHOCK FLIP CHIP LEFT	3	099.26044	
19	SHOCK FLIP CHIP RIGHT	1	099.26045	
20	DISC MOUNT	1	SET 6	
21	SCREW BOLT, M6x15	2	SET 6	12Nm
22	CABLE GUIDE	3	SET 7	
23	CABLE GUIDE	2	099.26046	
24	SCREW BOLT, M2,5x5	3	SET 7	1Nm

ITEM No.	DESCRIPTION	QTY.	PART NUMBER	TORQUE
25	SCREW BOLT, M3x10	7	SET 7 & 099.20068	1Nm
26	SHOCK BOLT, 70L	1	SET 2 & 099.26051	10Nm
27	CHARGE PORT COVER	1	099.26052	
28	CHAIN GUIDE OUTER	1	SET 5	
29	SCREW BOLT, M5x10	1	SET 9	5Nm
30	SCREW BOLT, M5x8	1	SET 9	2Nm
31	SCREW BOLT, M5x30	1	SET 9	5Nm
32	MOTOR COVER	1	099.26054	
33	TYRE FENDER	1	099.26055	
34	YOKE FENDER	1	099.26056	
35	FRONT FENDER	1	099.26057	
36	DOWN TUBE PROTECTOR	1	099.20058	
37	CHAINSTAY PROTECTOR	1	099.26059	
38	RUBBER CABLE PROTECTOR	1	099.26060	
39	CHAIN GUIDE BASE PLATE	1	SET 5	
40	SCREW BOLT, M4x10	3	099.26061	2Nm
41	SCREW BOLT, M5x12	2	SET 5	1,5Nm
42	SCREW BOLT, M4x10	4	099.20078	1Nm
43	SCREW BOLT, M3x10	2	099.26063	1Nm
44	CABLE GUIDE, COVER	2	099.26047	
45	SCREW BOLT, M5x8	4		1Nm
46	REAR AXLE	1	112.90027	
47	CHAINSTAY YOKE PROTECTOR	1	099.26109	



DETAIL 01

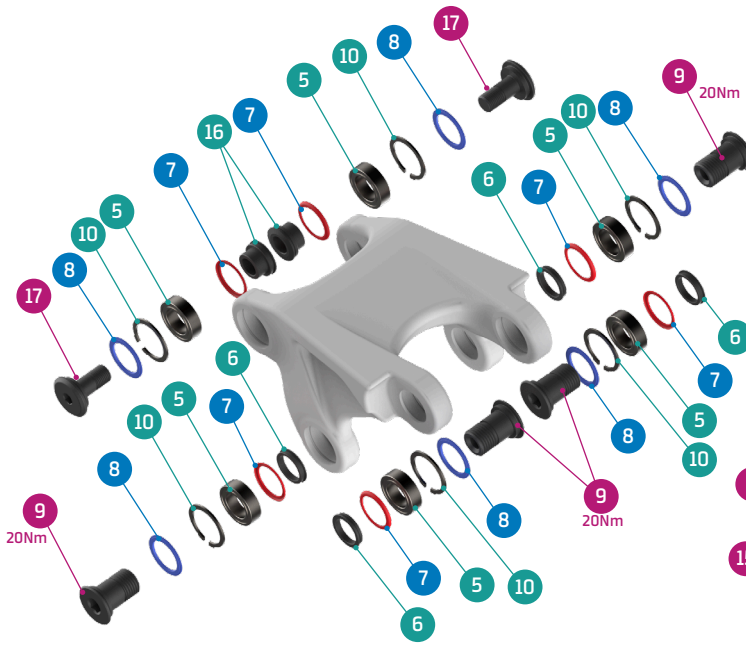

DETAIL 02

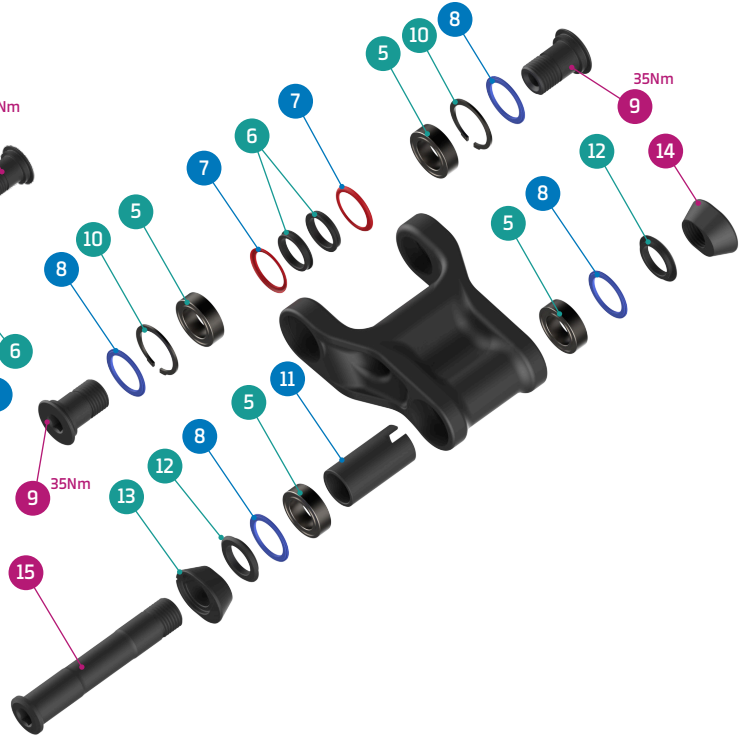

SET 6

DISC ADAPTOR KIT



SET 7

CABLE GUIDE KIT



SET 8

SEALS KIT

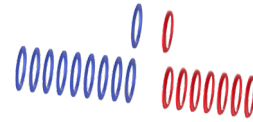

SET 9

BATTERY BOLTS KIT



SET 1

ZERO BEARING KIT 25



SET 2

SHOCK HARDWARE KIT 23

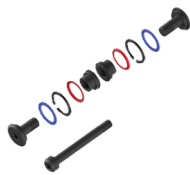

SET 3

UPPER LINK KIT 34

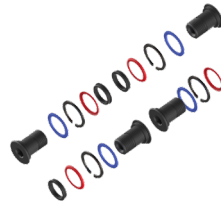

SET 4

LOWER LINK KIT 38

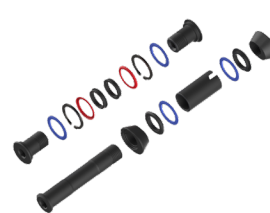

SET 5

CHAIN GUIDE PLATE + BOLTS



PART NUMBER	DESCRIPTION	COMPONENTS
099.22100	SET 1: ZERO BEARING KIT 25	BEARING 3802-2RS, 24x15x7 (x10)
099.26201	SET 2: SHOCK HARDWARE KIT 23	PIVOT SEAL INTERNAL (x2) / PIVOT SEAL EXTERNAL (x2) / C-RING (x2) / SPACER, 10x17x6 (x2) / SHOCK BOLT (x2) / SHOCK BOLT, 70 (x1)
099.26300	SET 3: UPPER LINK KIT 34	PIVOT WASHER (x4) / PIVOT SEAL INTERNAL (x4) / PIVOT SEAL EXTERNAL (x4) / PIVOT AXLE, M15 (x4) / C-RING (x4)
099.26400	SET 4: LOWER LINK KIT 38	PIVOT WASHER (x2) / PIVOT SEAL INTERNAL (x2) / PIVOT SEAL EXTERNAL (x4) / PIVOT AXLE, M15 (x2) / C-RING (x2) / SCPACER, 38 (x1) / SCPACER LOWER (x1) / PIVOT CHIP LEFT (x1) / PIVOT CHIP RIGHT (x1) / PIVOT AXLE, 81 (x1)
099.26064	SET 5: CHAIN GUIDE PLATE + BOLTS	CHAIN GUIDE BASE (x1) / CHAIN GUIDE OUTER PLATE (x1) / SCREW BOLT, M5X12 (x2) / SCREW BOLT, M5x10 (x1)
099.25018	SET 6: DISC ADAPTOR KIT	DISC ADAPTOR (x1) / SCREW BOLT (x2)
099.26048	SET 7: CABLE GUIDE KIT	CABLE GUIDE (x1) / SCREW BOTL M2.5X5L (x1) / SCREW BOLT M3X10L (x1)
099.26062	SET 8: SEALS KIT	PIVOT SEAL INTERNAL (x8) / PIVOT SEAL EXTERNAL (x10)
099.26053	SET 9: BATTERY BOLTS KIT	SCREW BOLT, M5x10 (x1) / SCREW BOLT, M5x30 (x1)



21. FAQs

HABE ICH BEI BENUTZUNG EINES 29"-HINTERRADS DIE GLEICHE REIFENFREIHEIT UND DIE GLEICHE KOMPATIBILITÄT FÜR BREMSSCHEIBEN? MUSS ICH DABEI IRGENDETWAS AN DEN EINSTELLUNGEN DES FAHRRADS ÄNDERN?

Wenn Sie das Fahrrad auf ein 29-Zoll-Hinterrad umrüsten, müssen Sie lediglich die Position des Flip-Chips am unteren Umlenkhebel ändern. Die Kettenstrebenlänge verlängert sich im Vergleich zum Standard-Mullet-Setup um 7 mm, wobei sich die Reifenfreiheit und die Position des Bremssattels nicht verändern. Unser Fahrrad wird serienmäßig in der Mullet-Konfiguration ausgeliefert. Bevor Sie mit dem 29-Zoll-Hinterrad losfahren, müssen Sie die Avinox Ride App verbinden und die Radkonfiguration aktualisieren.

HABE ICH BEI BENUTZUNG EINES 29"-HINTERRADS DIE GLEICHE REIFENFREIHEIT UND DIE GLEICHE KOMPATIBILITÄT FÜR BREMSSCHEIBEN? MUSS ICH DABEI IRGENDETWAS AN DEN EINSTELLUNGEN DES FAHRRADS ÄNDERN?

Wenn du das Fahrrad für ein 29er-Hinterrad einstellst, musst du lediglich die Position am Lower Link ändern. Die Kettenstrebenlänge vergrößert sich dabei um 7 mm im Vergleich zur Standard-Mullet-Konfiguration. Die Reifenfreiheit oder die Position des Bremssattels ändern sich jedoch nicht. Unser Fahrrad ist serienmäßig auf die Mullet-Konfiguration eingestellt. Bevor du mit einem 29-Zoll-Hinterrad losfährst, musst du die Avinox Ride App verbinden und die Radkonfiguration aktualisieren.

ICH FAHRE LIEBER EIN FULL-29. WARUM WIRD DAS ZENDIT ALS SERIENMODELL NUR ALS MULLET-OPTION ANGEBOTEN?

Mullet-Setups (29" vorne/27,5" hinten) sorgen für ein verspielteres, agileres Fahrgefühl mit präziserem Handling, unabhängig vom Fahrkönnen oder der Rahmengröße. Wenn du ein 29-Zoll-Hinterrad bevorzugst, kannst du dank der Flip-Chip-Einstellung des Zendit deine Konfiguration ganz einfach ändern, um das gewünschte Setup zu erhalten, ohne die Geometrie oder Kinematik zu verändern – lediglich die Kettenstrebe wird um 7 mm verlängert. Stelle daher sicher, dass du der serienmäßigen Kettenlänge von 120 Gliedern zwei zusätzliche Kettenglieder hinzufügst, sodass die Gesamtlänge 122 Glieder beträgt. Alle Zendit-Modelle und -Größen sind serienmäßig mit einer SRAM Transmission T-Type-Schaltung ausgestattet.

WIE VIEL WIEGT DER NEUE ZENDIT-RAHMEN?

Das Gewicht des neuen Stealth-Air-Carbon-Rahmensets ist bei den Modellen Zendit RR, RR S und XR identisch und liegt bei 3.000 Gramm einschließlich der Dämpfer-Hardware bei einem lackierten Rahmen in Größe ML ohne Dämpfer.

WELCHE DÄMPFER SIND MIT DEM NEUEN ZENDIT KOMPATIBEL?

Neben den Dämpfern Fox Float X und Fox Float X2, mit denen wir die verschiedenen Zendit-Modelle ausstatten, ist das Fahrrad auch mit der Fox DHX Coil-Serie, Öhlins TTX Air oder TTX22 m.2 Coil sowie RockShox Coil oder Air kompatibel (mit Ausnahme der Modelle Vivid Air und Vivid Coil, die nicht in die Rahmengrößen S und M passen). Das Zendit verfügt über metrische Dämpfer in der Größe 205 x 65 mm mit Trunnion-Oberbefestigung und standardmäßiger 30x8 mm unterer Befestigung. Überprüfen Sie vor der Installation eines anderen, größeren Hinterbaudämpfers, ob dieser passt, da der Ausgleichsbehälter (Piggyback) bei voller Kompression das Hauptrohr berühren könnte.

DT-SWISS HAT MIT SEINEN DEG-NABEN EINE NEUE SPERRKLINKE-TECHNOLOGIE AUF DEN MARKT GEBRACHT – IST DIESE AUF DEM ZENDIT VERFÜGBAR?

Ja, sowohl die Zendit RR S- als auch die XR-Modelle sind mit DEG DF-Naben mit Anti-Pedal-Kickback-Technologie und einer E-Bike-spezifischen Freilaufbewegung von 0 oder 10 Grad ausgestattet. Die Bikes werden standardmäßig mit dem Freilauf in der 10-Grad-Position ausgeliefert.



21. FAQs

WELCHE KINEMATIK-UPDATES BIETET DIESES NEUE ZENDIT?

Das Neat war unser erstes Modell mit dem weiterentwickelten Zero-Suspension-Design und seiner kompakten Bauweise überhaupt. Entsprechend den neuesten Leistungsentwicklungen, die bei anderen Mondraker-Fullsuspension-Bikes der jüngsten Generation wie dem Crafty und dem Level zu sehen sind, wurde das Zendit-Layout der neuesten Generation aktualisiert und verbessert. Das Zendit 2027 bietet einen etwas progressiveren Hinterbau mit einer Progressionsrate von 25,7 % und einem höheren Hebelverhältnis. Dadurch wird es im oberen Bereich geschmeidiger und sensibler. Zudem verfügt es über etwas flachere Anti-Squat- und Anti-Rise-Kurven, die den Dämpfer leistungsfähiger machen und für eine insgesamt besser Funktion sorgen. Länge und Hub des Dämpfers sind mit 205 x 65 mm ebenfalls größer als beim Neat. Der empfohlene Sag liegt bei etwa 28 % (18 mm Sag), die maximale Empfehlung bei 33 % (21,5 mm Sag).

WAS IST DER MAXIMALE FEDERWEG FÜR FEDERGABELN BEI DEN 2027ER ZENDIT-MODELLEN?

Das Zendit ist mit Federgabeln mit bis zu 180 mm Federweg oder 600 mm Abstand von Achse zu Gabelkrone kompatibel. Wir empfehlen jedoch die serienmäßig verbauten 170-mm-Federgabeln, um die perfekte Geometrie und Gewichtsverteilung bei allen Größen zu gewährleisten.

IST ES MÖGLICH, EINE GRÖßERE 220 MM BREMSSCHEIBE AM HINTERRAD DES ZENDIT ZU VERWENDEN?

Ja, das Zendit ist mit bis zu 220 mm großen Bremscheiben am Hinterrad kompatibel. Angesichts der neuesten leistungsstarken Bremsmodelle wie der serienmäßigen SRAM Maven, die an den verschiedenen Modellen verbaut sind, empfehlen wir dies zwar nicht, aber es ist möglich.

ES GIBT BEIM ZENDIT ZWEI GEOMETRIE-POSITIONEN, WIE FUNKTIONIERT DAS?

Genau wie bei unseren Crafty Carbon- oder Level-Modellen bietet das Zendit zwei Geometrie-Positionen per Flip-Chip. Das Fahrrad wird ab Werk in der Standardposition geliefert, und durch Umdrehen des Chips gelangt man in die Low-Position, in der das Tretlager um 5 mm tiefer liegt und sich der Lenkwinkel um 0,35° reduziert. Das ist ganz einfach. Löse dazu die untere Schraube des Dämpfers mit einem 6-mm-Inbusschlüssel und drehe die vier Aluminiumteile auf beiden Seiten um (zwei pro Seite – innen und außen), wie auf dem Rahmen abgebildet. Drehe die Dämpferschraube wieder ein – fertig. Die vollständigen Geometriewerte findest du auf der Mondraker-Website.

WELCHE IST DIE MAXIMALE REIFENBREITE, DIE AUF DAS ZENDIT PASST?

Das Zendit ist mit Reifen bis zu einer Breite von 66 mm kompatibel. Das entspricht 27,5- oder 29 x 2.6-Zoll-Reifen. Es wird empfohlen, den Reifen vor dem Einbau zu vermessen, da die tatsächliche Breite je nach Hersteller variieren kann.

WÄRE ES MÖGLICH, EINEN AKKU-EXTENDER AM ZENDIT ANZUBRINGEN, UM DIE REICHWEITE ZU ERHÖHEN UND LÄNGER ZU FAHREN?

Nein, das Zendit mit Avinox-Motor kann nur über den internen 800-Wh-Akku gespeist werden und ein Range Extender ist nicht erhältlich.

KANN ICH EINE TRINKFLASCHE MITNEHMEN?

Ja, das geht. Es gibt zwei mögliche Positionen für einen Flaschenhalter: im Hauptrahmen, also an der Standardposition wie bei jedem anderen Fahrrad, und unterhalb des Oberrohrs.

DIE NEUE KABELFÜHRUNG VERLÄUFT EXTERN DURCH DAS STEUEROHR. IST ES MÖGLICH, DIE KABEL INTERN DURCH DEN STEUERSATZ ZU FÜHREN?

Ja, das geht. Die neue obere Headset-Lagerschale ist so vorbereitet, dass die Kabel durch sie hindurchgeführt werden können. Somit ist eine vollständig interne Kabelführung möglich, falls du das bevorzugst.

IST ES MÖGLICH, DEN INTERNEN AKKU ZU DEMONTIEREN?

Ja, indem man zuerst den Motor ausbaut. Dieser Vorgang muss von einem qualifizierten Mechaniker bei einem autorisierten Händler durchgeführt werden. Bei Mondraker raten wir jedoch davon ab, den Akku zu demontieren.



21. FAQs

WIE LANGE DAUERT ES, DEN AKKU VOLLSTÄNDIG AUFZULADEN?

Mit dem Schnellladegerät (12A – GaN – 508W) des XR-Modells, kannst du den Akku in nur 1 Stunde und 30 Minuten von 0 auf 75 % und in 2 Stunden und 25 Minuten von 0 auf 100 % laden. Mit dem Standard-Ladegerät (4A - 168 W) der Modelle RR S und RR dauert es 4 Stunden und 28 Minuten, um den Akku von 0 auf 75 % und 5 Stunden und 10 Minuten von 0 auf 100 % aufzuladen.

Die T-Type-Schaltwerke der neuesten Generation von SRAM können über das Powercord direkt an den Hauptakku des Fahrrads angeschlossen werden. Ist das auch bei den neuesten Zendit-Modellen möglich?

Ja, diese Funktion ist bei allen Zendit-Modellen serienmäßig vorhanden. Dank ihr ist die Auto-Shift-Funktion bei jedem Schaltvorgang verfügbar, auch im Leerlauf.

Ja, diese Funktion ist serienmäßig bei allen Zendit RR-, RR S- und XR-Modellen enthalten. Dank dieser Konfiguration ist die SmoothShift-Funktion verfügbar und erscheint auf deinem Avinox-Display als Option zum Aktivieren oder Deaktivieren. Wenn SmoothShift eingeschaltet ist und ein Gangwechsel erkannt wird, dreht der Motor das Kettenblatt automatisch unabhängig von den Kurbeln, sodass du im Ausrollen (ohne zu treten und ohne die Kurbeln zu bewegen) in einen höheren oder niedrigeren Gang schalten kannst. Zum Schutz des Antriebsstrangs nutzt das System eine Multisensor-Fusion, um das Motordrehmoment während dieser Schaltvorgänge kurzzeitig zu reduzieren und so sicherzustellen, dass die Kette sanft zwischen den Zahnrädern läuft. Diese Präzision verhindert übermäßigen Verschleiß, indem die Motordrehung für die Dauer des Schaltvorgangs an die Radgeschwindigkeit angepasst wird, wobei das volle Drehmoment sofort wiederhergestellt wird, sobald der Gangwechsel abgeschlossen ist.

ZENDIT VERFÜGT ÜBER EINEN SRAM T-TYPE-ANTRIEB. WÄRE ES MÖGLICH, EINEN SHIMANO-ANTRIEB UND EIN SHIMANO-SCHALTWERK ZU VERWENDEN?

Ja, auf jeden Fall. Beachte lediglich, dass du ein zusätzliches UDH-Schaltauge für das Shimano-Schaltwerk benötigst.

WELCHE MAXIMALE UNTERSTÜTZUNG KANN ICH VOM AVINOX M2S-MOTOR DES ZENDIT ERHALTEN?

Die maximale Unterstützung beträgt 800% mit 150 Nm und 1.300 W im Boost-Modus.

KANN MAN DIE UNTERSTÜTZUNGSMODI BEIM ZENDIT INDIVIDUELL ANPASSEN?

Ja, du kannst die Avinox M2S-Unterstützungsmodi des Zendit genauso anpassen wie bei anderen Motorsystemen. Das geht direkt über das Display am Fahrrad oder über die Avinox Ride App auf deinem Handy. Die Bedienung ist sehr einfach und du kannst alle Fahrparameter ganz leicht nach deinen Wünschen anpassen. Auf der Avinox-Website <https://www.avinox-ebike.com/> oder in der Avinox Ride App findest du alle Informationen zur Motoranpassung und zur Einstellung der verschiedenen Unterstützungsmodi Auto, Eco, Trail, Turbo und Boost.

WIE WEIT KANN ICH MIT DEM NEUEN ZENDIT FAHREN?

Das ist immer eine knifflige Frage und hängt stark vom gewählten Unterstützungsmodus, der Fitness des Fahrers, dem Fahrergewicht und den Fahrbedingungen ab. Mit dem serienmäßigen 800-Wh-Akku kann ein durchschnittlicher Fahrer mit 80 kg Fahrergewicht bei Kombination verschiedener Unterstützungsmodi rund 2.000 Höhenmeter bewältigen und im AUTO-ECO-Modus bis zu vier Stunden fahren. Auch hier gilt: Es kommt auf die Fahrbedingungen und die körperliche Verfassung des Fahrers an.

WELCHE INFORMATIONEN BIETET DAS ZENDIT-DISPLAY?

Alle Informationen zum Display und zur Bedieneinheit findest du unter diesem Link: <https://www.avinox-ebike.com/>



21. FAQs

WELCHE ART VON WARTUNG ODER SICHERHEITSÜBERPRÜFUNGEN BENÖTIGT DER AVINOX M2S-MOTOR?

Absolut keine. Es ist auch nicht erforderlich, Teile der Antriebseinheit zu schmieren oder sie zu zerlegen... Du musst das Zendit lediglich wie ein herkömmliches Mountainbike pflegen. Es ist jedoch wichtig, als Vorsichtsmaßnahme für jedes Mountainbike zu erwähnen: Elektronische Teile und insbesondere der Tretlagerbereich der Antriebseinheit dürfen niemals mit einem Hochdruckreiniger gereinigt werden. Auch die Reinigung der Kurbelachse mit einem Hochdruckwasserstrahl wird nicht empfohlen, da die elektronischen Teile der Antriebseinheit dadurch ernsthaft beschädigt werden können.

WELCHE RAHMENGRÖSSE BRAUCHE ICH?

Die Zendit-Modelle sind in fünf Größen erhältlich, wobei die Größe ML zwischen Medium und Large liegt. Im Vergleich zu den vier Größen, die wir bei verschiedenen Mondraker-Modellen anbieten, sind die neuen Größen Small und Medium etwas kleiner als die bisherigen Größen Small und Medium bei Modellen mit nur vier Größen. Die neuen Größen Large und Extra Large sind ebenfalls etwas größer. Schau dir die Geometrie-Tabellen an, um weitere Informationen und alle Details zu erhalten. Hier ist ein Überblick über die empfohlenen Größen für bestimmte Körpergrößen.

<165 cm	165-170 cm	170-175 cm	175-180 cm	180-185 cm	185-190 cm	190-195 cm	>195 cm
S			M/L				XL
	M				L		



Alle Informationen und Bilder in diesem Dokument dienen nur zu Informationszwecken und stellen keinen rechtlichen Vertrag zwischen Mondraker und einer natürlichen oder juristischen Person dar. Spezifikationen, Geometrien und andere veröffentlichte technische Informationen können ohne vorherige Ankündigung geändert werden.

© © Alle Marken und Modelle sind Eigentum von Blue Factory Team, S.L.U. und durch geltende Gesetze und anwendbare internationale Übereinkommen geschützt.

MANUELS ET DOCUMENTS



CONSIGNES GÉNÉRALES ET DE SÉCURITÉ

Les 3 icônes suivantes peuvent apparaître dans ce guide technique. Chacune d'elles indique que les précautions indiquées doivent être prises :

AVERTISSEMENT :

Le non-respect des instructions ou une utilisation inappropriée du vélo peuvent causer des blessures graves, voire entraîner la mort. Ces opérations impliquent des difficultés techniques et, si elles ne sont pas effectuées correctement, elles pourraient endommager votre vélo ou entraîner l'annulation de la garantie.

ATTENTION :

Ne pas suivre les instructions ou utiliser le vélo de manière inappropriée peut provoquer des blessures légères. Ces tâches impliquent une difficulté technique et, si elles ne sont pas effectuées correctement, elles pourraient provoquer des dommages sur votre vélo ou entraîner l'annulation de la garantie.

INFORMATIONS

Informations indispensables à la réalisation correcte de cette tâche en évitant de causer des dommages au vélo ou de perdre la garantie, mais qui ne présentent aucun risque pour les personnes.

AUTRES CONSIDÉRATIONS

- L'utilisation de pièces de rechange non originales peut entraîner des dommages, des dysfonctionnements et des accidents aux conséquences graves..
- Pour effectuer certaines des opérations décrites dans ce manuel, des qualifications supérieures à celles de l'utilisateur de vélo moyen sont nécessaires. Si vous ne pouvez pas suivre l'une de ces étapes, apportez votre vélo auprès d'un revendeur Mondraker agréé pour effectuer l'entretien et le remplacement de ses composants. L'installation incorrecte de pièces de rechange peut entraîner des dysfonctionnements, des accidents, des blessures et l'annulation de la garantie.

NETTOYAGE ET ENTRETIEN

- Une fois les pièces démontées, il est recommandé de nettoyer, de graisser et de mettre du frein filet (si nécessaire) sur les composants que vous comptez réutiliser.

LÉGENDE DES SYMBOLES



Frein filet de niveau moyen. Loctite 243.



Graisse synthétique de qualité pour montage.



Graisse spéciale de friction pour carbone.

1. GÉOMÉTRIE

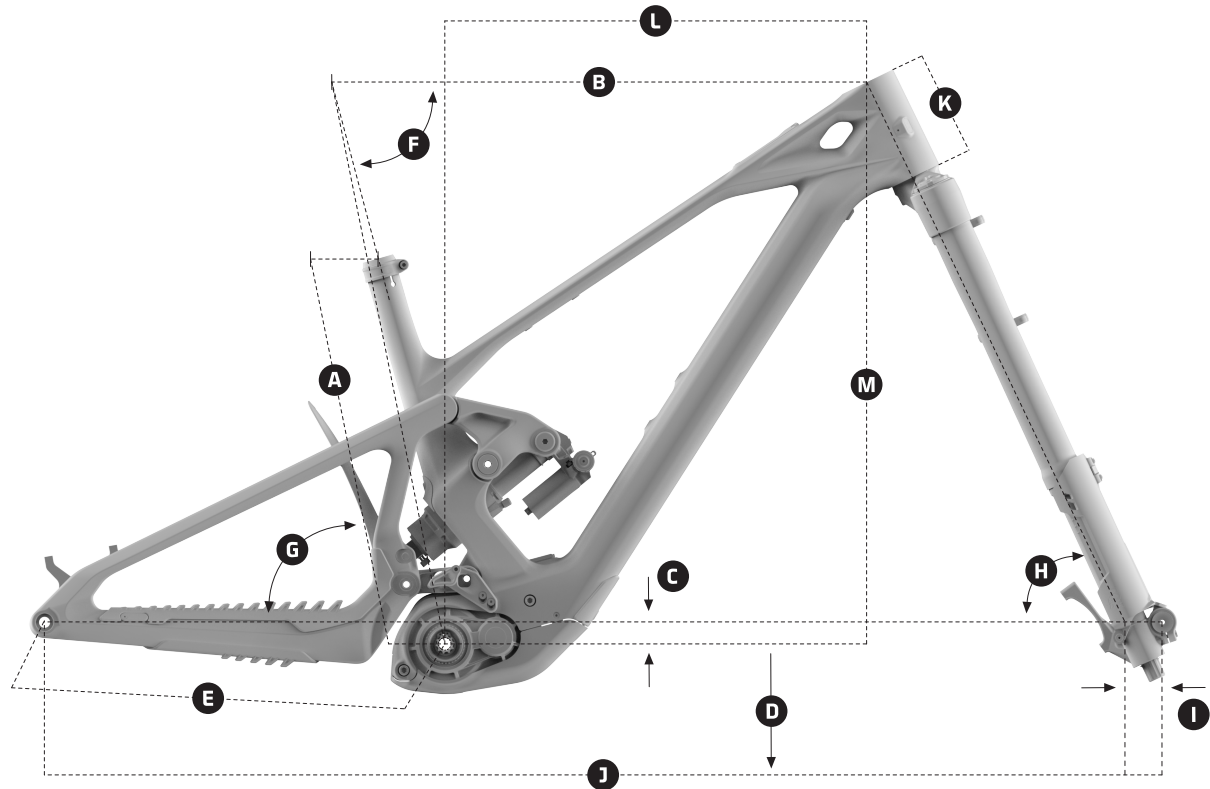

ZENDIT (FLIP CHIP POSITION STANDARD)

TAILLE DU CADRE		S	M	ML	L	XL
A	Longueur du tube de selle	380 mm	410 mm	435 mm	460 mm	490 mm
B	Longueur du tube supérieur	586 mm	606 mm	628 mm	650 mm	672 mm
C	Différence axe boîtier/axe moyeu	6 mm	6 mm	6 mm	6 mm	6 mm
D	Hauteur de pédalier	345 mm	345 mm	345 mm	345 mm	345 mm
E	Longueur des bases	450 mm	450 mm	450 mm	455 mm	455 mm
F	Angle de tube de selle	73,5°	73,5°	73,5°	73,5°	73,5°
G	Angle de tube de selle effectif	77,0°	77,0°	77,0°	77,0°	77,0°
H	Angle du tube de direction	63,5°	63,5°	63,5°	63,5°	63,5°
I	Déport de fourche	44 mm	44 mm	44 mm	44 mm	44 mm
J	Empattement	1241 mm	1261 mm	1286 mm	1315 mm	1339 mm
K	Longueur du tube de direction	110 mm	110 mm	120 mm	130 mm	140 mm
L	Reach	440 mm	460 mm	480 mm	500 mm	520 mm
M	Stack	631 mm	631 mm	640 mm	649 mm	658 mm

* La longueur des bases augmente de 7 mm lors du montage d'une roue arrière de 29"



1. GÉOMÉTRIE

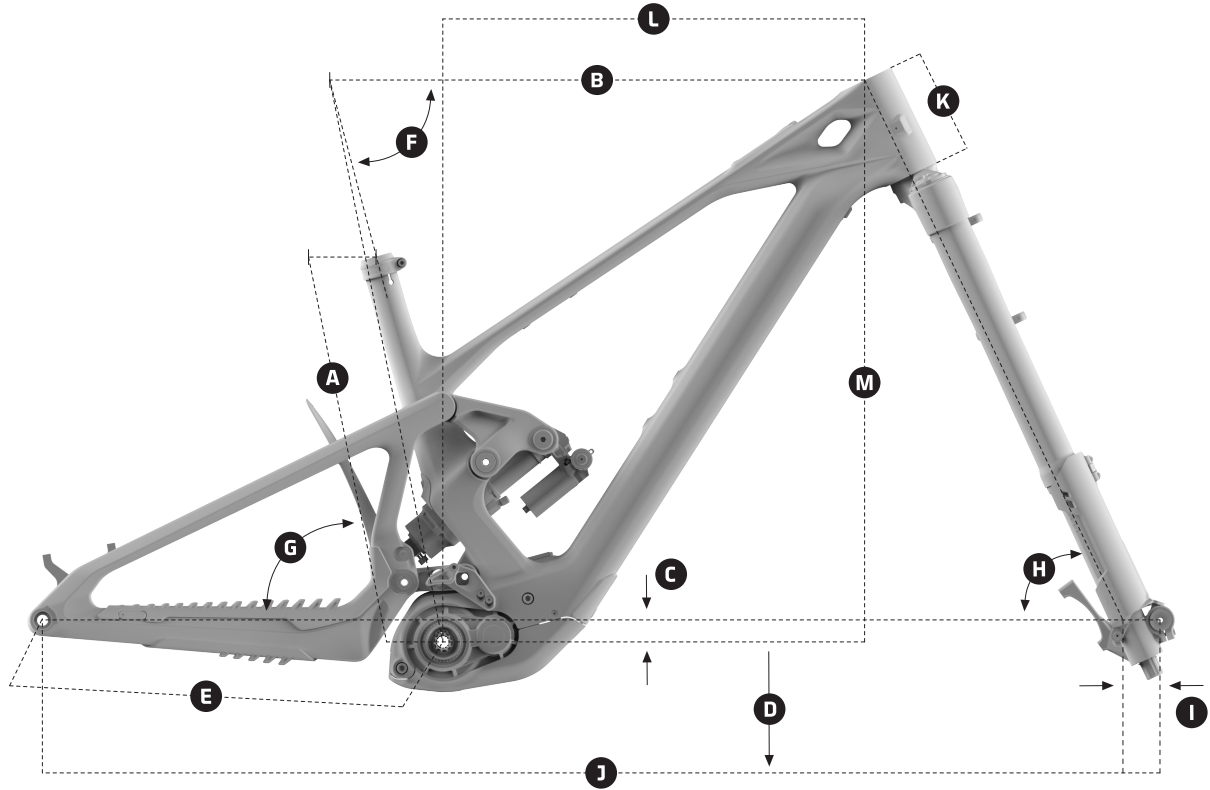

ZENDIT (FLIP CHIP POSITION LOW)

TAILLE DU CADRE		S	M	ML	L	XL
A	Longueur du tube de selle	380 mm	410 mm	435 mm	460 mm	490 mm
B	Longueur du tube supérieur	586 mm	606 mm	629 mm	651 mm	673 mm
C	Différence axe boîtier/axe moyeu	11 mm	11 mm	11 mm	11 mm	11 mm
D	Hauteur de pédalier	340 mm	340 mm	340 mm	340 mm	340 mm
E	Longueur des bases	451 mm	451 mm	451 mm	456 mm	456 mm
F	Angle de tube de selle	73,15°	73,15°	73,15°	73,15°	73,15°
G	Angle de tube de selle effectif	76,65°	76,65°	76,65°	76,65°	76,65°
H	Angle du tube de direction	63.15°	63.15°	63.15°	63.15°	63.15°
I	Déport de fourche	44 mm	44 mm	44 mm	44 mm	44 mm
J	Empattement	1242 mm	1262 mm	1287 mm	1316 mm	1340 mm
K	Longueur du tube de direction	110 mm	110 mm	120 mm	130 mm	140 mm
L	Reach	436 mm	456 mm	476 mm	496 mm	516 mm
M	Stack	633 mm	634 mm	643 mm	652 mm	661 mm

* La longueur des bases augmente de 7 mm lors du montage d'une roue arrière de 29"



2. SPÉCIFICATIONS TECHNIQUES DU CADRE

TAILLE DE CADRE	S / M / ML / L / XL
TAILLE ROUE AVANT (pouces)	29"
AXE AVANT	110mm x 20mm (BOOST)
TAILLE ROUE ARRIÈRE (pouces)	27.5" / 29"
AXE ARRIÈRE	148mm x 12mm (BOOST)
ESSIEU ARRIÈRE	12X148 P1.0 L180
NOMBRE D'EMPLACEMENTS PORTE-BIDONS	Tube diagonal pour porte-bidon, tube supérieur pour accessoires.
MOTEUR	Avinox
BOÎTIER DE PÉDALIER	Avinox
BATTERIE	800Wh
COMPATIBILITÉ AVEC RANGE EXTENDER	-
DÉBATTEMENT ARRIÈRE	165mm
AMORTISSEUR ARRIÈRE	205 x 65mm TRUNNION, 30 x 8mm
DÉBATTEMENT AVANT	170mm
DIAMÈTRE DE LA TIGE DE SELLE	31.6mm / 36.9mm
LIGNE DE CHAÎNE DIRECTION	55mm
JEU DE DIRECTION	ZS56 / ZS56, 1-1/8", 1.5"
NOMBRE DE DENTS MAXIMAL (PLATEAU)	36T
FREIN ARRIÈRE	POST MOUNT, DIRECT 220mm max
DÉGAGEMENT MAXIMAL PNEUS	29" x 2.6" (66-622)

3. PROFONDEUR D'INSERTION DE TIGE

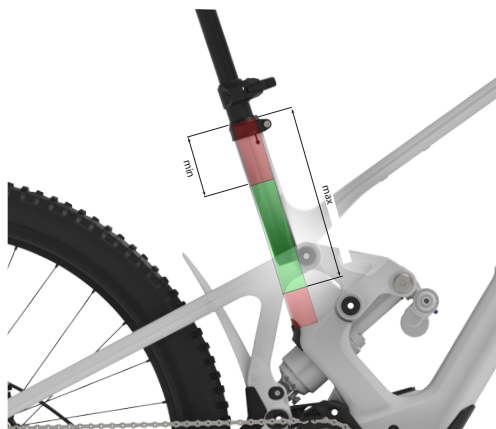

TAILLE CADRE	MIN. (mm)	MAX. (mm)
XL	100	300
L	100	270
ML	100	244
M	100	220
S	100	190



4. COMPOSANTS TRANSMISSION

4.1. GUIDE CHAÎNE

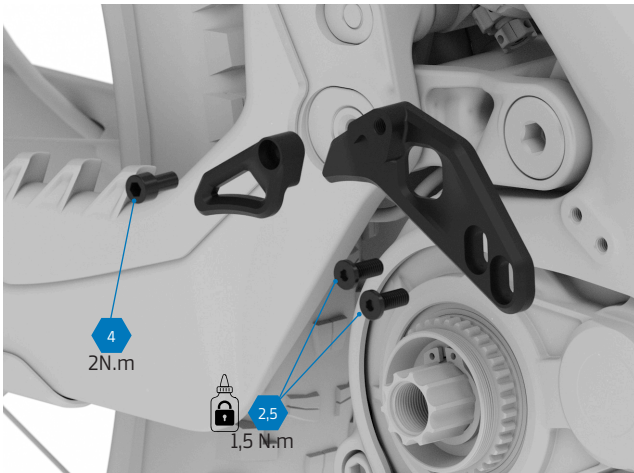

4.2. PLATEAU

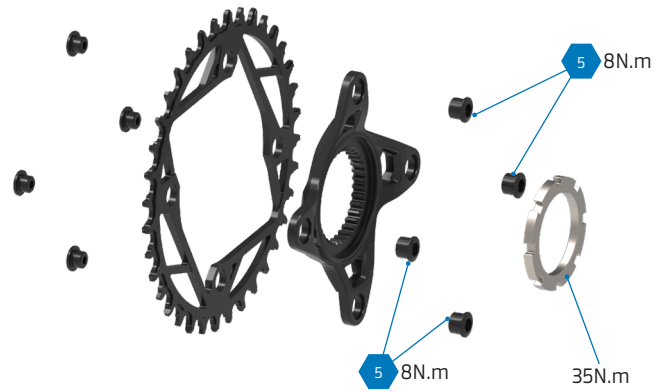

5. COUVERCLE DU MOTEUR

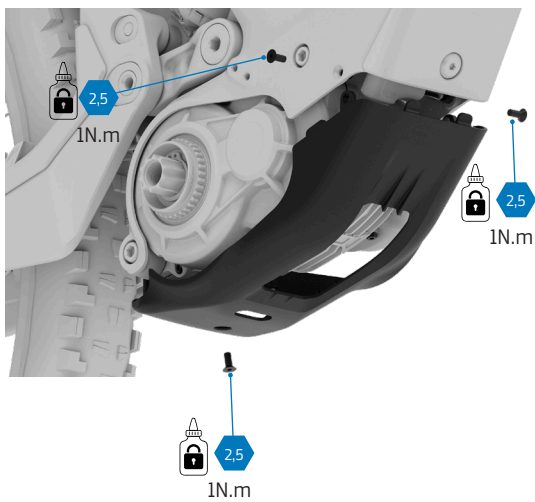

6. MOTEUR

6.1. FIXATION DU MOTEUR AU CADRE

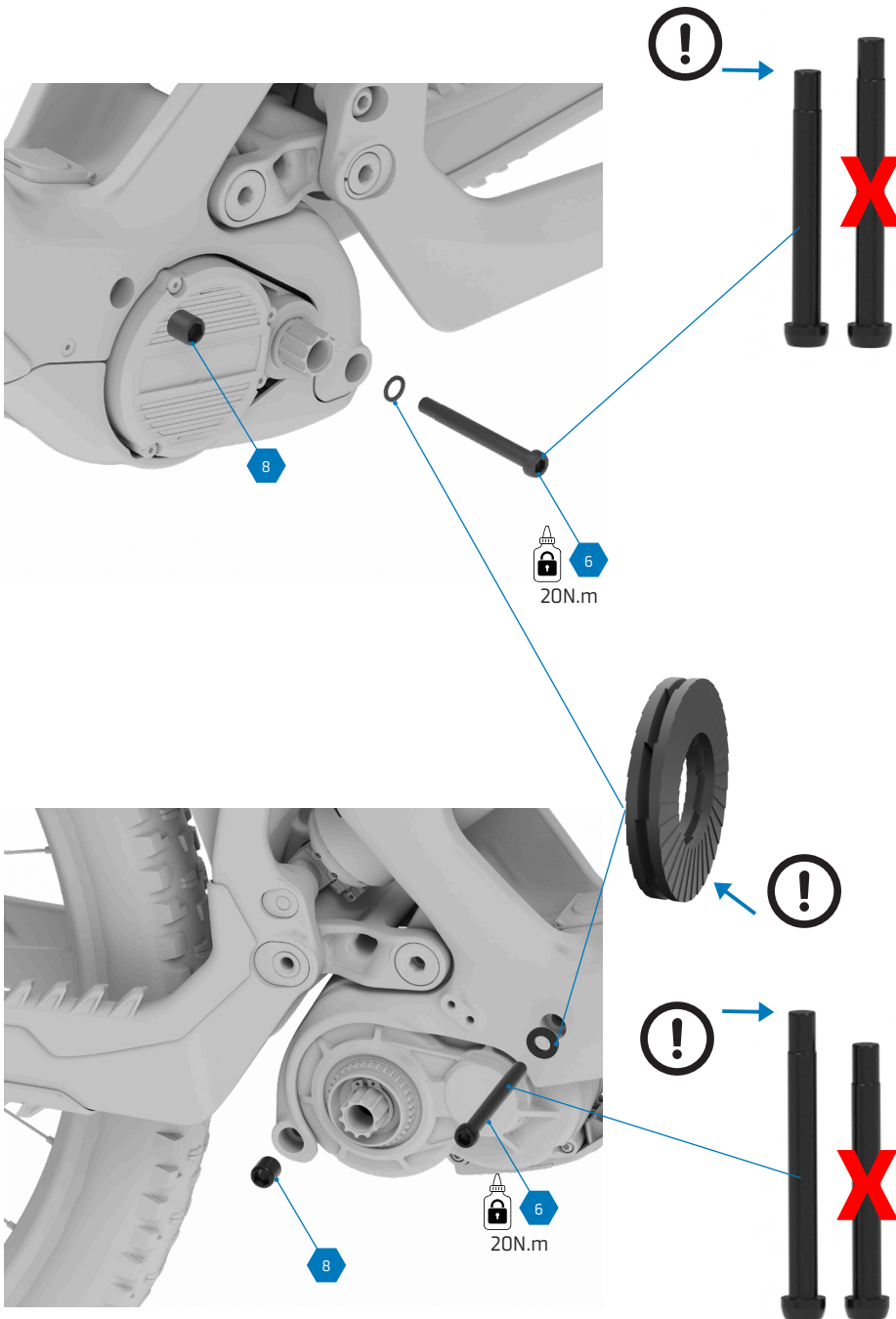

6. MOTEUR

6.2. ENTRETOISES ENTRE LE CADRE ET LE MOTEUR

Cette étape n'est nécessaire que lors du remplacement du moteur ou du cadre par un neuf. Les moteurs et cadres assemblés chez Mondraker sont déjà équipés des bonnes entretoises.

Un outil spécial AVINOX est nécessaire pour réaliser cette tâche.

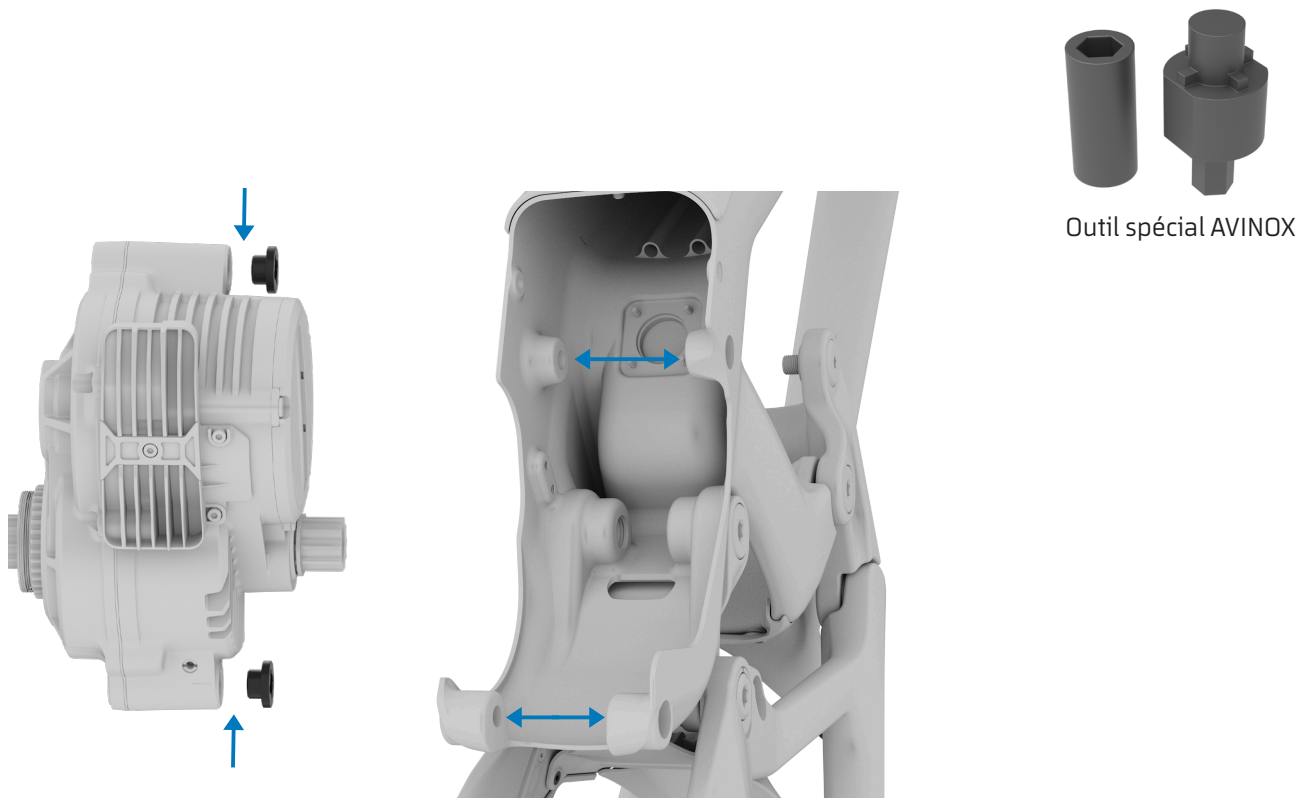

En cas de remplacement du cadre ou du moteur, il est nécessaire de mesurer avec un pied à coulisse la distance entre les surfaces d'appui en carbone du logement du moteur. En fonction de cette mesure, il faudra installer les rondelles ou entretoises correspondantes entre le moteur et la vis, selon les valeurs indiquées dans le tableau. Il est impératif de vérifier les dimensions aux points d'ancrage avant et arrière, car elles peuvent différer et nécessiter ainsi un nombre différent d'entretoises. Le serrage final des vis doit être effectué à l'aide de l'outil spécial AVINOX, en appliquant un couple de serrage de **5 Nm**.

A = X - 56.7mm (Point d'ancrage avant) A = Y - 47.1mm (Point d'ancrage arrière)

Jeu entre le cadre et le moteur	Nombre de rondelles du point de montage
$A < 0.25\text{mm}$	0
$0.25\text{mm} \leq A < 0.50\text{mm}$	0
$0.50\text{mm} \leq A < 0.75\text{mm}$	2
$0.75\text{mm} \leq A < 1.00\text{mm}$	3
$A = 1.00\text{mm}$	4
$A > 1.00\text{mm}$	La tolérance du cadre est anormale : l'unité d'entraînement ne peut pas être installée.



7. PORT DE CHARGEMENT

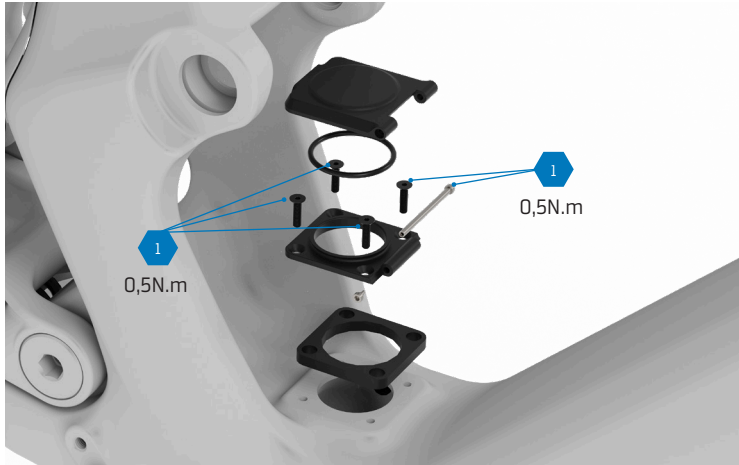

8. PASSAGE INTERNE DES CÂBLES

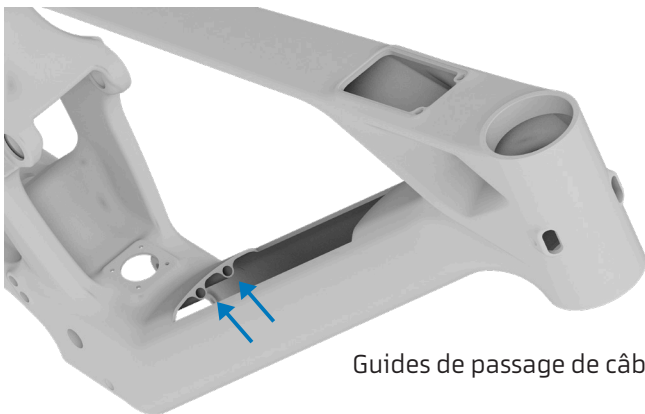
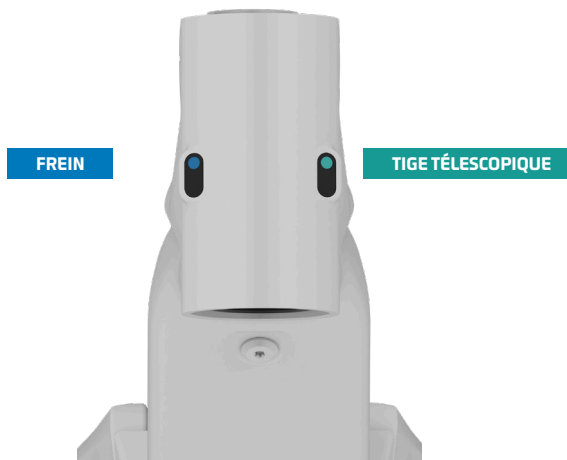

Guides de passage de câbles interne



8. PASSAGE INTERNE DES CÂBLES

8.1. ENTRÉES DE CÂBLES

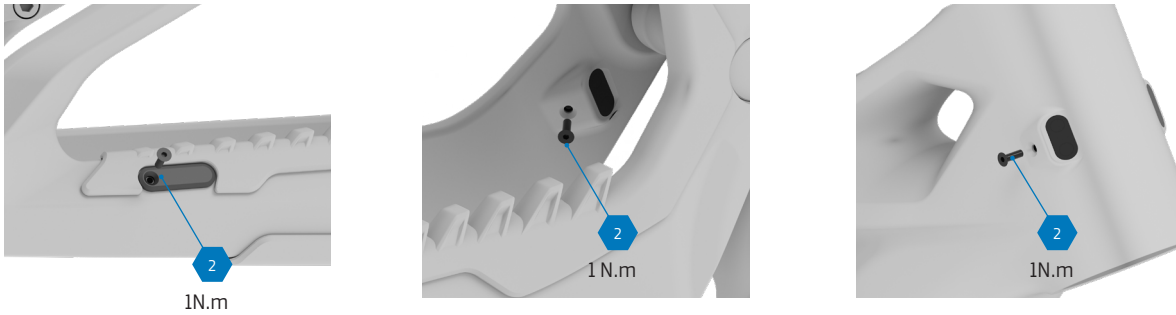

8.2. ENTRÉE DU CAPTEUR DE VITESSE

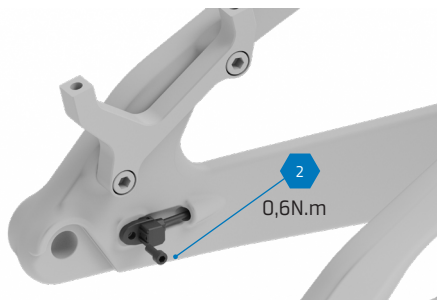

9. VIS DE FIXATION DE LA BATTERIE

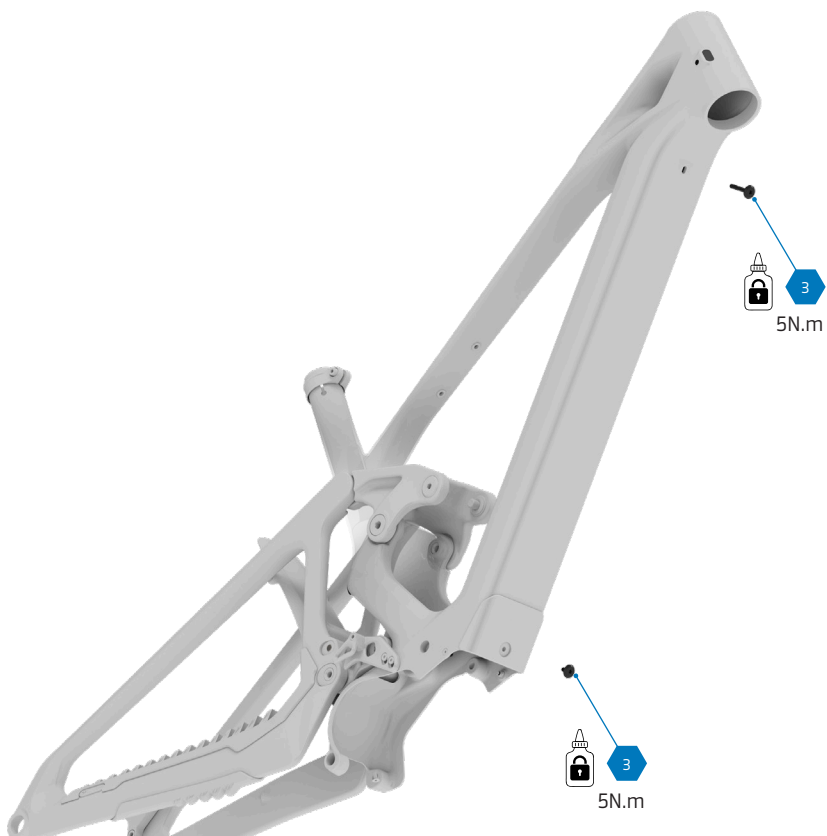



10. ÉCRAN



11. COMMANDE SANS FIL

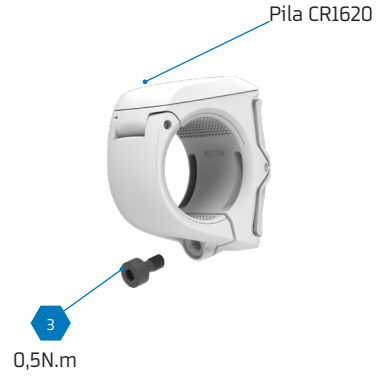

12. GARDE-BOUE

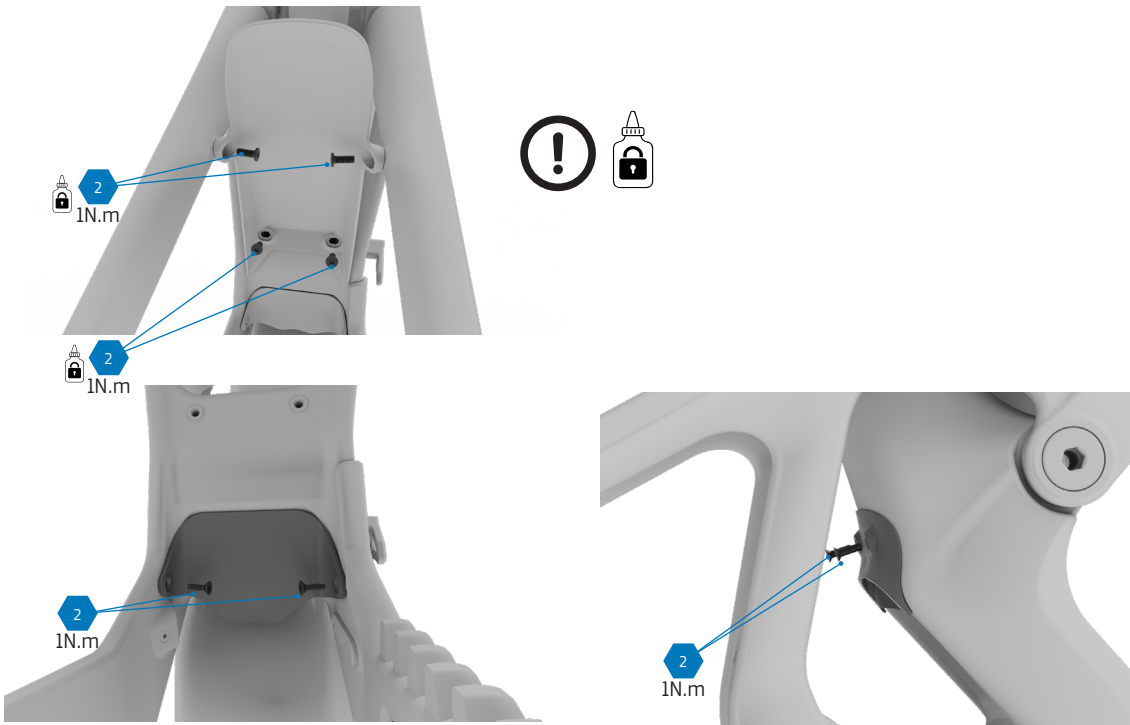

15. COLLIER DE SELLE



Il est recommandé d'utiliser de la graisse de friction pour carbone sur la tige de selle

16. GUIDE D'INSTALLATION DE LA BIELLETTE SUPÉRIEURE



Utilisez de la Loctite 243 pour le filetage.
Astuce de Pro : Au lieu d'appliquer le frein filet sur la vis, vous pouvez le mettre directement dans le filetage interne du cadre du vélo. Cela évite de contaminer les autres composants avec le frein filet lors de l'insertion de la vis.

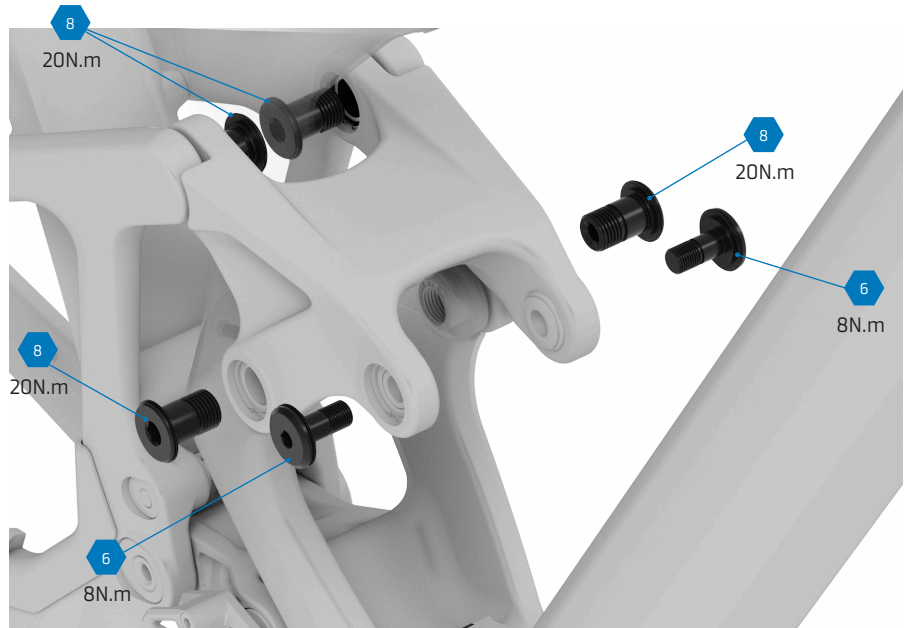
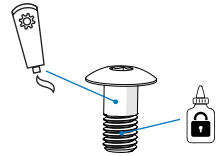

Pour les vis principales, appliquez de la graisse sur la tige, et du Loctite 243 sur les filetages

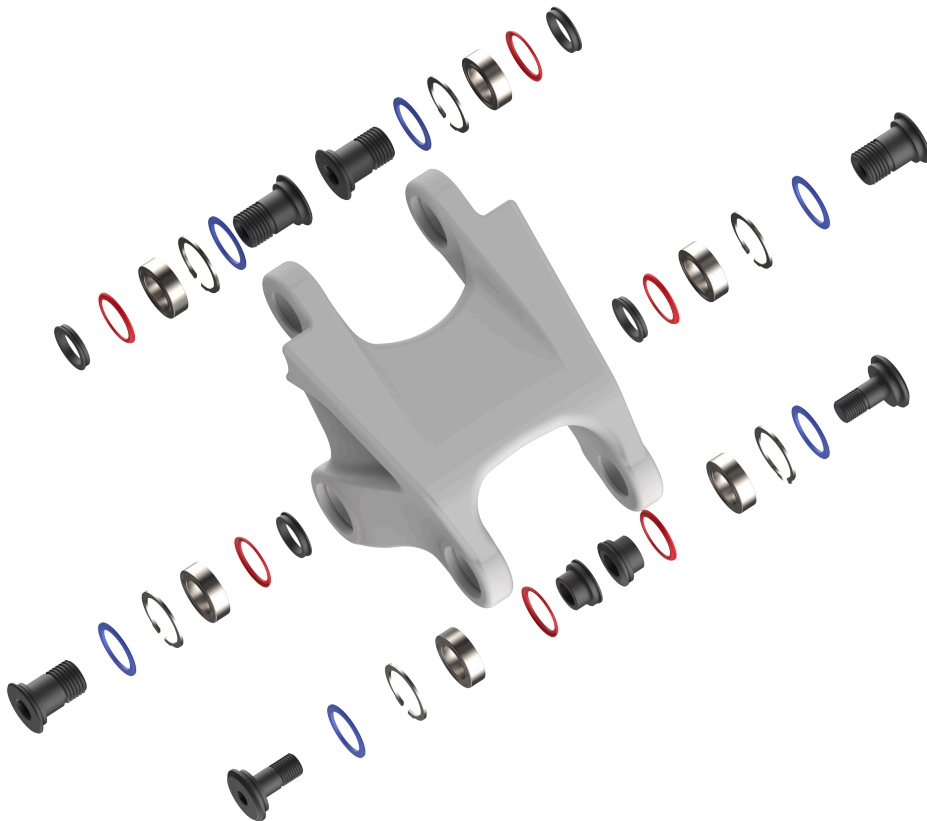

Faites particulièrement attention à la position des joints en caoutchouc.



Appliquez de la graisse sur les zones de friction tout en évitant de contaminer les filetages

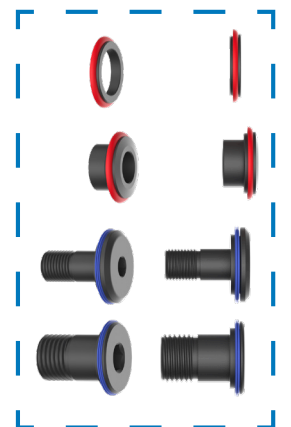

17. GUIDE D'INSTALLATION DE LA BIELLETTE INFÉRIURE

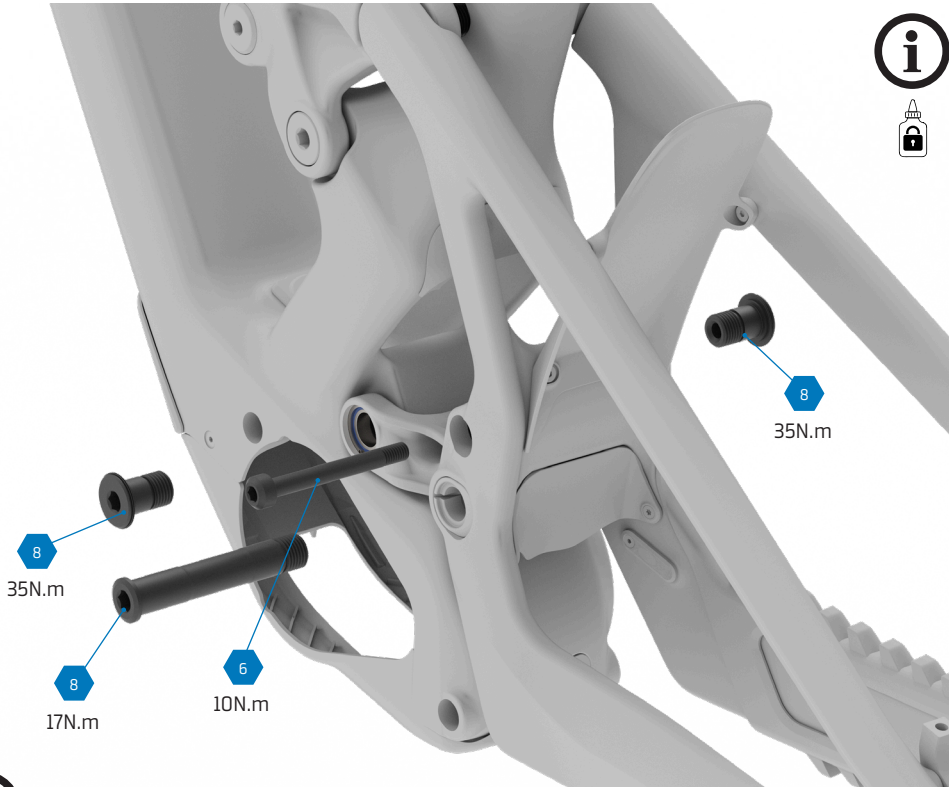

Utilisez de la Loctite 243 pour le filetage.



Astuce de Pro : Au lieu d'appliquer le frein filet sur la vis, vous pouvez le mettre directement dans le filetage interne du cadre du vélo. Cela évite de contaminer les autres composants avec le frein filet lors de l'insertion de la vis.

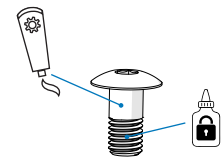

Pour les vis principales, appliquez de la graisse sur la tige, et du Loctite 243 sur les filetages

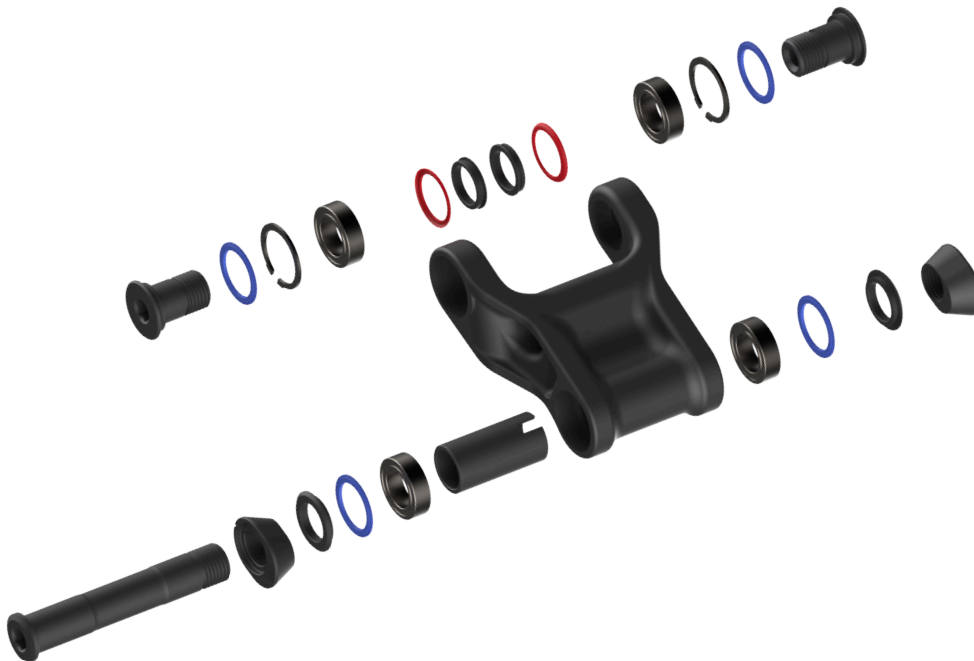

Faites particulièrement attention à la position des joints en caoutchouc.



Appliquez de la graisse sur les zones de friction tout en évitant de contaminer les filetages

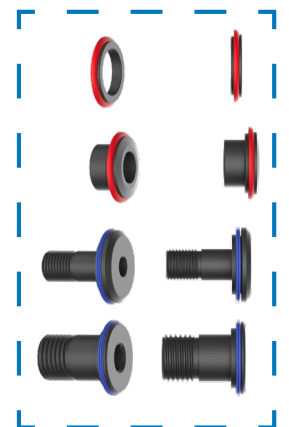



18. FLIP CHIP

18.1 FLIP CHIP POUR CHANGEMENT DE TAILLE DE ROUE 27.5"-29"

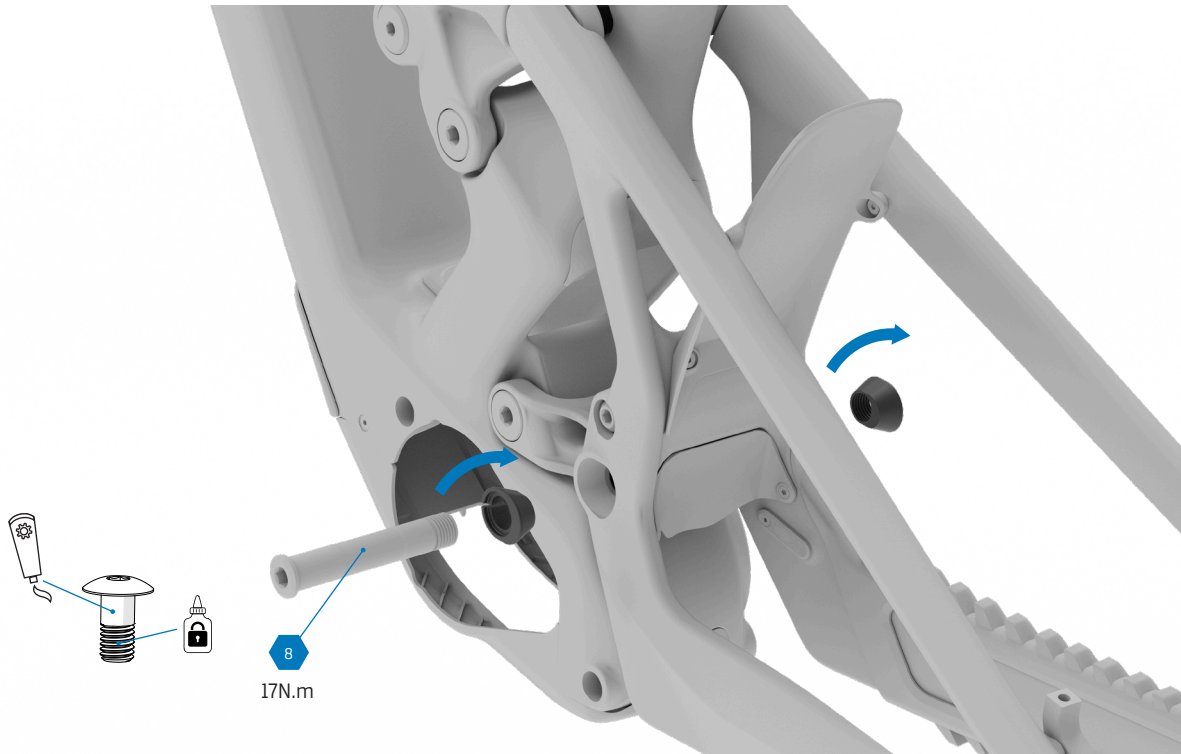

- ❗ Pour les vis principales, appliquez de la graisse sur la tige, et du Loctite 243 sur les filetages
- ❗ Appliquez de la graisse sur les zones de friction tout en évitant de contaminer les filetages
- ❗ Lors du passage de roues de 27,5" à 29", veillez à ajouter 2 maillons supplémentaires à la longueur de la chaîne. En 27,5", elle compte 120 maillons ; en 29", 122 maillons. Veuillez également connecter l'application Avinox Ride et mettre à jour les paramètres du wheel set-up.

18.2 FLIP CHIP POUR CHANGEMENT DE CINÉMATIQUE STD - LOW

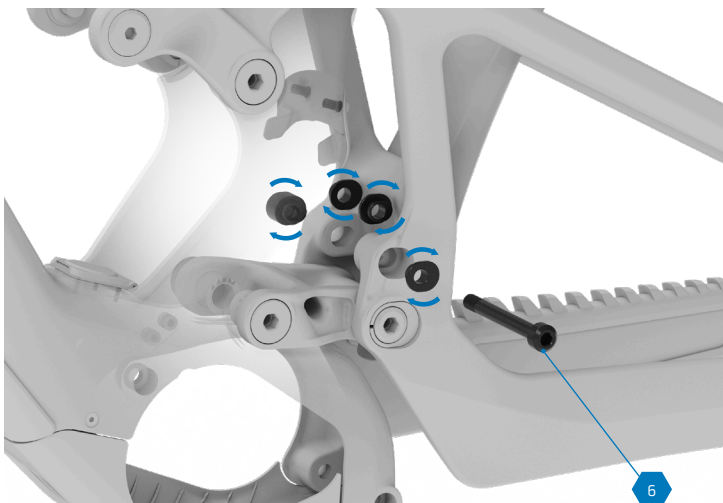

Le flip chip pour le changement de cinématique se compose de 4 pièces : 2 externes et 2 internes.



20. SPARE PARTS
ZENDIT

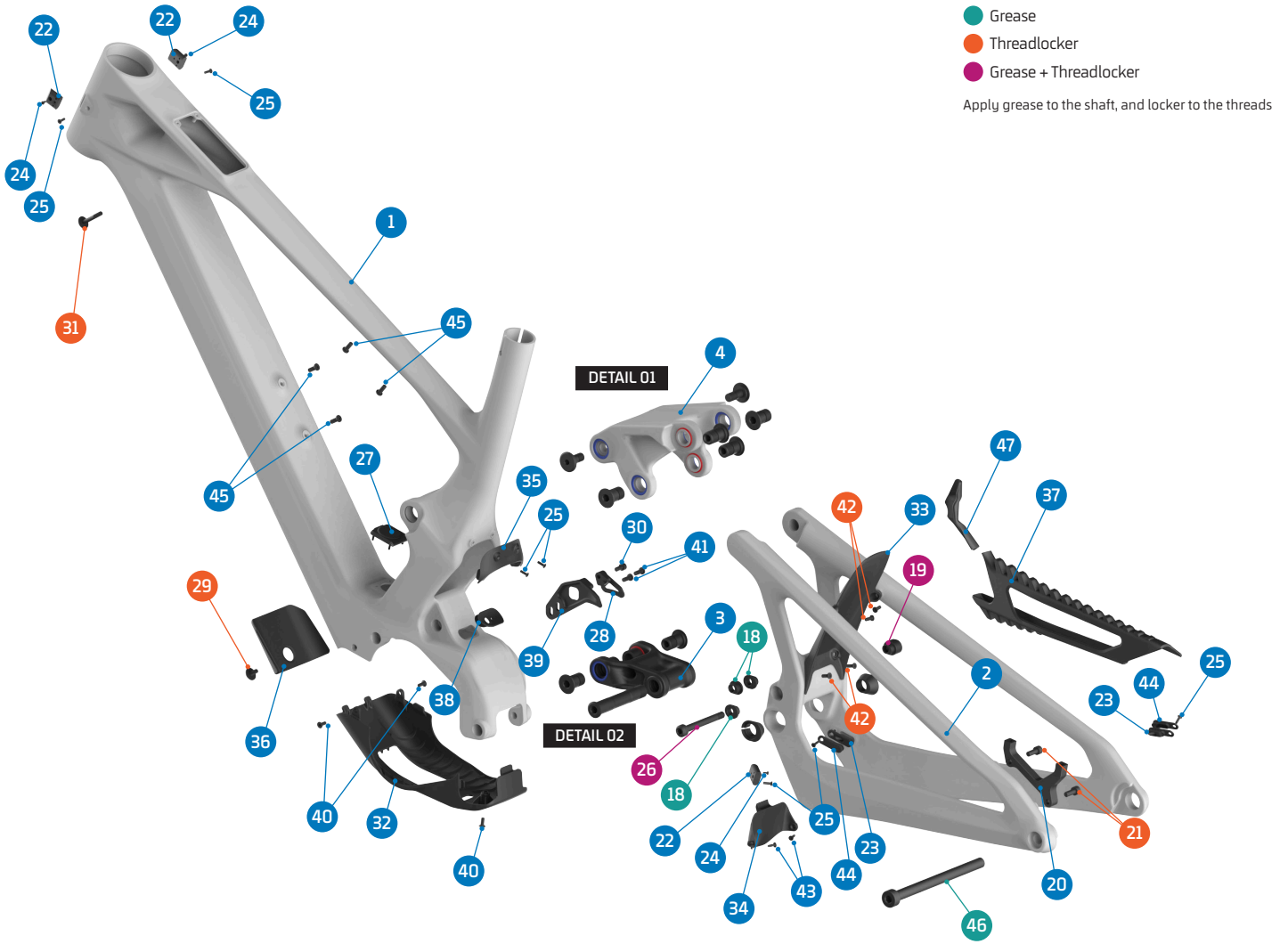

ITEM No.	DESCRIPTION	QTY.	PART NUMBER	TORQUE
1	FRAME	1		
2	REAR TRIANGLE	1		
3	LOWER LINK	1	099.26038	
4	UPPER LINK	1	Refer to B2B web for color options	
5	BEARING, 24x15x7 (3802-2RS)	10	SET 1 / 099.00113	
6	PIVOT WASHER	6	SET 3 & 4	
7	PIVOT SEAL, INTERNAL	8	SET 2, 3, 4 & 8	
8	PIVOT SEAL, EXTERNAL	10	SET 2, 3, 4 & 8	
9	PIVOT AXLE, M15	6	SET 3 & 4	35Nm / 20Nm
10	C-RING	8	SET 2, 3 & 4	
11	SPACER, 38L	1	SET 4	
12	SPACER, LOWER	2	SET 4	
13	PIVOT CHIP, LEFT	1	SET 4 & 099.26049	
14	PIVOT CHIP, RIGHT	1	SET 4 & 099.26050	
15	PIVOT AXLE, 81L	1	SET 4	17Nm
16	SPACER, 10x17x6	2	SET 2	
17	SHOCK BOLT	2	SET 2	8Nm
18	SHOCK FLIP CHIP LEFT	3	099.26044	
19	SHOCK FLIP CHIP RIGHT	1	099.26045	
20	DISC MOUNT	1	SET 6	
21	SCREW BOLT, M6x15	2	SET 6	12Nm
22	CABLE GUIDE	3	SET 7	
23	CABLE GUIDE	2	099.26046	
24	SCREW BOLT, M2,5x5	3	SET 7	1Nm

ITEM No.	DESCRIPTION	QTY.	PART NUMBER	TORQUE
25	SCREW BOLT, M3x10	7	SET 7 & 099.20068	1Nm
26	SHOCK BOLT, 70L	1	SET 2 & 099.26051	10Nm
27	CHARGE PORT COVER	1	099.26052	
28	CHAIN GUIDE OUTER	1	SET 5	
29	SCREW BOLT, M5x10	1	SET 9	5Nm
30	SCREW BOLT, M5x8	1	SET 9	2Nm
31	SCREW BOLT, M5x30	1	SET 9	5Nm
32	MOTOR COVER	1	099.26054	
33	TYRE FENDER	1	099.26055	
34	YOKE FENDER	1	099.26056	
35	FRONT FENDER	1	099.26057	
36	DOWN TUBE PROTECTOR	1	099.20058	
37	CHAINSTAY PROTECTOR	1	099.26059	
38	RUBBER CABLE PROTECTOR	1	099.26060	
39	CHAIN GUIDE BASE PLATE	1	SET 5	
40	SCREW BOLT, M4x10	3	099.26061	2Nm
41	SCREW BOLT, M5x12	2	SET 5	1,5Nm
42	SCREW BOLT, M4x10	4	099.20078	1Nm
43	SCREW BOLT, M3x10	2	099.26063	1Nm
44	CABLE GUIDE, COVER	2	099.26047	
45	SCREW BOLT, M5x8	4		1Nm
46	REAR AXLE	1	112.90027	
47	CHAINSTAY YOKE PROTECTOR	1	099.26109	



21. FAQS

AURAI-JE LE MÊME DÉGAGEMENT DE ROUE ARRIÈRE ET LA MÊME COMPATIBILITÉ DE DISQUE EN ROULANT EN 29" À L'ARRIÈRE ? DOIS-JE MODIFIER DES RÉGLAGES ?

Lors du passage en roue arrière de 29", il suffit de modifier la position du flip-chip inférieur. La longueur des bases augmente de 7 mm par rapport à la configuration mullet standard, mais le dégagement ainsi que la position de l'étrier de frein restent inchangés. Le vélo est livré en configuration mullet, mais pour rouler en 29" arrière, il est nécessaire de se connecter à l'application Avinox Ride et de mettre à jour la configuration des roues.

JE PRÉFÈRE ROULER EN FULL 29"; POURQUOI LE ZENDIT EST-IL PROPOSÉ EN MULLET DE SÉRIE ?

La configuration mullet (29" avant / 27,5" arrière) offre un comportement plus joueur, agile et précis, quel que soit le niveau du rider ou la taille du vélo. Si vous préférez une roue arrière de 29", le flip-chip du ZENDIT permet d'ajuster facilement la configuration sans modifier la géométrie ni la cinématique, uniquement la longueur des bases +7 mm.

Important : prévoir 2 maillons supplémentaires (chaîne passant de 120 à 122 maillons). Tous les modèles ZENDIT sont équipés de transmissions SRAM T-Type.

QUEL EST LE POIDS DU CADRE ZENDIT ?

Le nouveau cadre Stealth Air Carbon équipant les modèles Zendit RR, RR S et XR est identique et pèse exactement 3 000 grammes, avec les fixations d'amortisseur incluses, sur un cadre peint de taille ML sans l'amortisseur arrière.

QUELS AMORTISSEURS SONT COMPATIBLES AVEC LE ZENDIT ?

En plus des amortisseurs Fox Float X et Fox Float X2 dont nous équipons les différents modèles Zendit, le vélo est également compatible avec la série Fox DHX à ressort, Öhlins TTX à air ou TTX22 m.2 à ressort, et RockShox à ressort ou à air (à l'exception des modèles Vivid Air et Vivid Coil qui ne sont pas compatibles avec les cadres de taille S et M). Le Zendit est équipé d'amortisseurs métriques de 205 x 65 mm avec une fixation supérieure Trunnion et un matériel standard inférieur de 30x8 mm. Vérifiez avant d'installer un autre amortisseur arrière plus grand car il pourrait ne pas s'adapter, le réservoir (piggyback) risquant de heurter le tube principal en pleine compression.

LES MOYEURS DT SWISS AVEC TECHNOLOGIE DEG SONT-ILS DISPONIBLES SUR LE ZENDIT ?

Oui, les modèles Zendit RR S et XR sont tous deux équipés de moyeux dotés de la technologie anti-retour de pédalier DEG DF (DEG DF anti-pedal kickback), avec un angle de rotation de la roue libre de 0 ou 10 degrés, spécialement adapté aux vélos électriques. Les vélos sont livrés de série avec la roue libre réglée en position standard à 10 degrés.

AURAI-JE LE MÊME DÉGAGEMENT ET LA MÊME COMPATIBILITÉ EN 29" ARRIÈRE ? FAUT-IL MODIFIER LES RÉGLAGES ?

Oui. En configurant le vélo en 29" arrière, il suffit de modifier la position du flip-chip inférieur. La longueur des bases augmente de 7 mm, mais le dégagement et la position de l'étrier de frein ne changent pas. Contrairement à certaines configurations, aucun réglage interne via l'écran n'est nécessaire.

QUELLES AMÉLIORATIONS CINÉMATIQUES APPORTE CETTE NOUVELLE ZENDIT ?

Le modèle Original Neat a été notre tout premier vélo à intégrer la conception évoluée de la suspension Zero, avec son design compact. Cette nouvelle génération de Zendit a été mise à jour et améliorée pour suivre les dernières avancées en matière de performances observées sur d'autres vélos tout suspendus Mondraker de dernière génération, tels que le Crafty et le Level. La génération Zendit 2027 offre une suspension arrière légèrement plus progressive avec un taux de progression de 25,7 %, un rapport de levier plus élevé pour une plus grande souplesse et une meilleure réactivité en début de course, ainsi que des courbes anti-squat et anti-rise légèrement plus basses pour une suspension arrière plus performante et plus polyvalente. La longueur et la course de l'amortisseur arrière sont également plus longues que celles du modèle d'origine, à 205 x 65 mm. Le SAG recommandé est d'environ 28 % (18 mm de SAG), avec une recommandation maximale de 33 % (21,5 mm de SAG).



21. FAQs

QUEL EST LE DÉBATTEMENT MAXIMUM DE FOURCHE ?

Le Zendit est compatible avec des fourches offrant un débattement maximum de 180 mm ou une distance axe-couronne de 600 mm ; toutefois, nous recommandons d'utiliser les fourches de série (170 mm) que nous proposons, afin de préserver la géométrie et l'équilibre de poids parfaits sur toutes les tailles.

PUIS-JE MONTER UN DISQUE ARRIÈRE DE 220 MM ?

Oui, le Zendit est compatible avec des disques de frein arrière plus grands, jusqu'à 220 mm. Compte tenu des derniers modèles de freins puissants, tels que les SRAM Maven de série que l'on retrouve sur différentes configurations et différents modèles, nous ne le recommandons. Les freins actuels offrant déjà une puissance largement suffisante.

COMMENT FONCTIONNENT LES DEUX POSITIONS DE GÉOMÉTRIE ?

Tout comme nos modèles Crafty Carbon ou Level, le Zendit offre deux positions géométriques grâce au flip-chip. La position standard est celle d'origine, tandis qu'il existe une position low où le boîtier de pédalier s'abaisse de 5 mm et où les angles changent de 0,35°. L'opération est très simple. Dévissez le boulon inférieur de l'amortisseur à l'aide d'une clé Allen de 6 mm et basculez les deux pièces en aluminium situées de part et d'autre du vélo, comme indiqué sur le cadre. Revissez le boulon de l'amortisseur et le tour est joué. Vous pouvez consulter l'ensemble des données géométriques sur le site web de Mondraker.

QUELLE LARGEUR DE PNEUS MAXIMALE ?

Le Zendit est compatible avec des pneus d'une largeur maximale de 66 mm, soit environ 2.6" en 27,5" ou 29".

Important : il est recommandé de mesurer le pneu avant l'installation, car la largeur réelle peut varier selon le fabricant.

PEUT-ON AJOUTER UN RANGE EXTENDER ?

Non. Le système Avinox fonctionne uniquement avec la batterie interne de 800 Wh, aucun range extender n'est disponible.

PEUT-ON MONTER UN PORTE-BIDON ?

Oui, c'est possible. Il existe deux emplacements possibles pour un porte-bidon : sur le triangle principal, à la position habituel comme sur n'importe quel autre vélo, et sous le tube supérieur.

LE PASSAGE DE CÂBLES PEUT-IL ÊTRE INTERNE ? À TRAVERS LE JEU DE DIRECTION ?

Oui. Le jeu de direction permet le passage des câbles et offrir un guidage entièrement interne si vous préférez cette configuration.

LA BATTERIE EST-ELLE DÉMONTABLE ?

C'est possible, à condition de retirer d'abord le moteur.

Important : cette opération doit être effectuée par un mécanicien qualifié chez un revendeur agréé, mais chez Mondraker, nous déconseillons formellement de démonter la batterie, quelles que soient les circonstances.

QUEL EST LE TEMPS COMPLET DE CHARGE DE LA BATTERIE ?

Avec le chargeur rapide de série du modèle XR (chargeur GaN 508 W à 12 A), vous pouvez passer de 0 à 75 % en seulement 1 h 30 et de 0 à 100 % en seulement 2 h 25. Sur les modèles RR S et RR, avec le chargeur standard de 4 A et 168 W, vous pouvez recharger la batterie de 0 à 75 % en 4 h 28 min et de 0 à 100 % en 5 h 10 min.



21. FAQs

LES DÉRAILLEURS ARRIÈRE SRAM DE DERNIÈRE GÉNÉRATION DE T-TYPE PEUVENT FONCTIONNER EN ÉTANT BRANCHÉS DIRECTEMENT SUR LA BATTERIE PRINCIPALE DU VÉLO À L'AIDE DU CÂBLE D'ALIMENTATION. EST-CE POSSIBLE AVEC LES DERNIERS MODÈLES ZENDIT ?

Oui, cette fonctionnalité est intégrée de série sur tous les modèles ZENDIT RR, RR S et XR. Grâce à cette configuration, la fonction SmoothShift est disponible et apparaît sur l'écran Avinox, avec la possibilité de l'activer ou de la désactiver.

Lorsque SmoothShift est activé et qu'un changement de vitesse est détecté, le moteur entraîne automatiquement le plateau indépendamment des manivelles, ce qui permet de changer de vitesse en roue libre, sans pédaler ni faire tourner les manivelles. Pour protéger la transmission, le système utilise une fusion multi-capteurs afin de réduire temporairement le couple moteur pendant le passage de vitesse, garantissant un déplacement fluide de la chaîne entre les pignons. Cette précision limite l'usure en synchronisant la rotation du moteur avec la vitesse de la roue pendant le changement, avant de restaurer instantanément la pleine puissance une fois le passage de vitesse terminé.

LE ZENDIT EST ÉQUIPÉ D'UNE TRANSMISSION SRAM DE TYPE T. SERAIT-IL POSSIBLE D'UTILISER UNE TRANSMISSION SHIMANO ET UN DÉRAILLEUR ARRIÈRE SHIMANO ?

Oui, tout à fait. Assurez-vous simplement de vous procurer une patte de dérailleur UDH compatible pour le dérailleur arrière Shimano.

QUELLE EST LA PUISSANCE MAXIMALE QUE JE PEUX OBTENIR DU MOTEUR AVINOX M2S DE ZENDIT ?

La puissance maximale est de 150 Nm et 1 300 W en mode Boost.

PEUT-ON PERSONNALISER LES MODES D'ASSISTANCE ?

Oui, vous pouvez personnaliser les modes d'assistance de l'Avinox M2S de Zendit de la même manière que pour les autres systèmes de motorisation. Vous pouvez le faire directement depuis l'écran du vélo ou via l'application Avinox Ride sur votre téléphone portable. C'est une opération très simple et vous pourrez personnaliser très facilement chaque paramètre de pilotage selon vos préférences. Sur le site Avinox <https://www.avinox-ebike.com/> ou via l'application Avinox Ride, vous trouverez toutes les informations relatives à la personnalisation du moteur et à la configuration des différents modes d'assistance : Auto, Eco, Trail, Turbo et Boost.

QUELLE AUTONOMIE PEUT-ON ESPÉRER ?

C'est toujours une question délicate, qui varie du niveau d'assistance utilisé, de la condition physique du cycliste, de son poids et des conditions. Avec la batterie standard de 800 Wh, un cycliste moyen pesant 80 kg peut gravir environ 2 000 m de dénivelé en combinant différents modes d'assistance et rouler jusqu'à 4 heures en modes AUTO-ECO. Encore une fois, cela dépend des conditions de pratique et de la condition physique du cycliste.

QUELLES INFORMATIONS S'AFFICHENT SUR L'ÉCRAN ?

Vous trouverez toutes les informations relatives à l'écran et au manuel de la télécommande en cliquant sur ce lien :

<https://www.avinox-ebike.com/>

QUELS TYPES D'ENTRETIEN OU DE CONTRÔLES DE SÉCURITÉ LE MOTEUR AVINOX M2S NÉCESSITE-T-IL ?

Absolument aucun. Il n'est pas non plus nécessaire de lubrifier les pièces du moteur ni de le démonter... il suffit simplement d'en prendre soin comme pour un VTT classique. Il est toutefois important de mentionner, à titre de précaution valable pour tout VTT, que les composants électroniques et, plus particulièrement, la zone du boîtier de pédalier du moteur ne doivent jamais être nettoyés à l'aide d'un nettoyeur haute pression. Il est déconseillé d'utiliser un jet d'eau à haute pression pour nettoyer directement l'axe de pédalier, car cela pourrait endommager gravement les composants électroniques du moteur.



21. FAQs

QUELLE TAILLE DE VÉLO CHOISIR ?

Les modèles Zendit sont disponibles en 5 tailles, avec une taille ML intermédiaire entre les tailles Medium et Large. Par rapport aux 4 tailles proposées sur différents modèles Mondraker, les nouvelles tailles Small et Medium sont légèrement plus petites que les anciennes Small et Medium de la gamme à 4 tailles, tandis que les nouvelles tailles Large et Extra Large sont quant à elles légèrement plus grandes. Consultez les tableaux de géométrie pour plus d'informations et tous les détails. Voici un aperçu des tailles recommandées en fonction de la taille du cycliste.

<165 cm	165-170 cm	170-175 cm	175-180 cm	180-185 cm	185-190 cm	190-195 cm	>195 cm
S			M/L			XL	
	M			L			



Toutes les informations et les photos figurant sur ce document sont fournies à titre informatif uniquement et ne constituent pas un contrat juridique entre Mondraker et toute personne ou organisme. Les spécifications, les géométries ou toute autre information technique publiée sont susceptibles de changer sans préavis.

© © Toutes les marques et tous les modèles sont la propriété de Blue Factory Team, S.L.U. et sont protégés par les lois en vigueur et les accords internationaux applicables.

MANUALI E DOCUMENTI





ISTRUZIONI GENERALI DI SICUREZZA

In questo manuale tecnico vengono utilizzati i seguenti 3 simboli. Questi simboli servono per prestare attenzione alle seguenti precauzioni:

PERICOLO:

Non seguire le indicazioni o utilizzare la bicicletta in modo improprio poiché potrebbero causare lesioni gravi o letali. Queste mansioni comportano difficoltà tecniche e, se sono eseguite male, potrebbero danneggiare la bicicletta o comportare l'annullamento della garanzia.

ATTENZIONE!

Non seguire le indicazioni o utilizzare la bicicletta in modo improprio può causare lesioni lievi. Queste mansioni comportano difficoltà tecniche e, se sono eseguite male, potrebbero danneggiare la bicicletta o comportare l'annullamento della garanzia.

INFORMAZIONI

Informazioni indispensabili per una corretta esecuzione dei procedimenti per evitare eventuali danni della bicicletta o perdita della garanzia, ma che non comportano alcun rischio per la persona.

ALTRE CONSIDERAZIONI

- L'uso di ricambi non originali può causare danni, malfunzionamenti e incidenti che possono portare a gravi conseguenze.
- Per eseguire i passaggi descritti in questo manuale, sono richieste competenze che vanno ben oltre le conoscenze di un'utilizzatore medio di bicicletta. Nel caso in cui non si è qualificati per seguire una delle seguenti indicazioni, si prega di portare la bicicletta presso un servizio tecnico autorizzato Mondraker per la manutenzione e la sostituzione dei suoi componenti. L'installazione errata dei pezzi di ricambio può causare malfunzionamenti, incidenti, lesioni e l'annullamento della garanzia.

PULIZIA E CURA

- Non appena i pezzi sono stati smontati, si consiglia di pulire, ingrassare e mettere il frenafletti (se necessario) sui componenti che verranno riutilizzati.

LEGENDA DEI SIMBOLI



Fissatore per filettature di grado medio. Loctite 243.



Grasso sintetico di qualità per il montaggio.



Grasso speciale carbonio per creare attriti.

1. GEOMETRIA

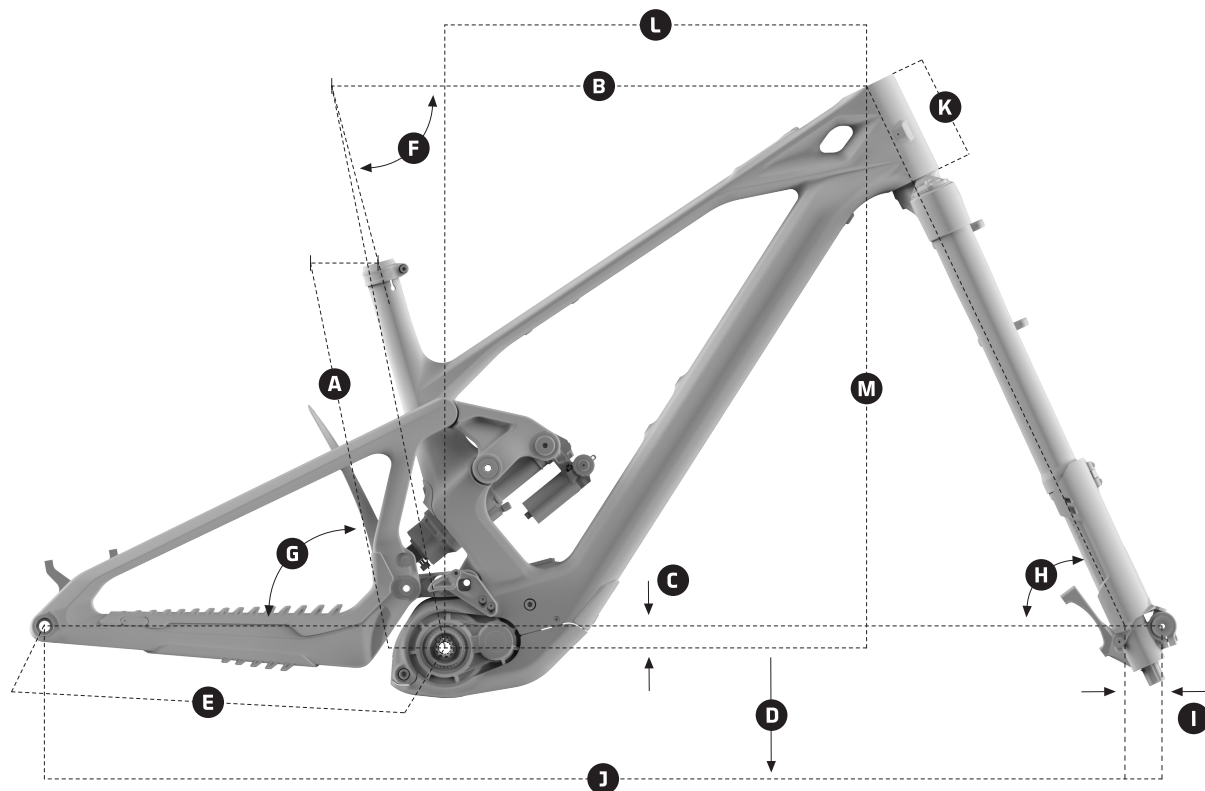

ZENDIT (FLIP CHIP POSIZIONE STANDARD)

DIMENSIONE DEL TELAIO	S	M	ML	L	XL
A Lunghezza Piantone	380 mm	410 mm	435 mm	460 mm	490 mm
B Lunghezza Tubo Orizz. Virtuale	586 mm	606 mm	628 mm	650 mm	672 mm
C BB Drop	6 mm	6 mm	6 mm	6 mm	6 mm
D Altezza movimento centrale	345 mm	345 mm	345 mm	345 mm	345 mm
E Lunghezza Batticatena	450 mm	450 mm	450 mm	455 mm	455 mm
F Angolo tubo sella	73,5°	73,5°	73,5°	73,5°	73,5°
G Angolo Sella	77,0°	77,0°	77,0°	77,0°	77,0°
H Angolo Sterzo	63,5°	63,5°	63,5°	63,5°	63,5°
I Offset Forcella / Rake	44 mm	44 mm	44 mm	44 mm	44 mm
J Interasse	1241 mm	1261 mm	1286 mm	1315 mm	1339 mm
K Lunghezza Tubo Sterzo	110 mm	110 mm	120 mm	130 mm	140 mm
L Reach	440 mm	460 mm	480 mm	500 mm	520 mm
M Stack	631 mm	631 mm	640 mm	649 mm	658 mm

* La lunghezza dei foderi orizzontali aumenta di 7 mm quando si monta una ruota posteriore da 29".



1. GEOMETRIA

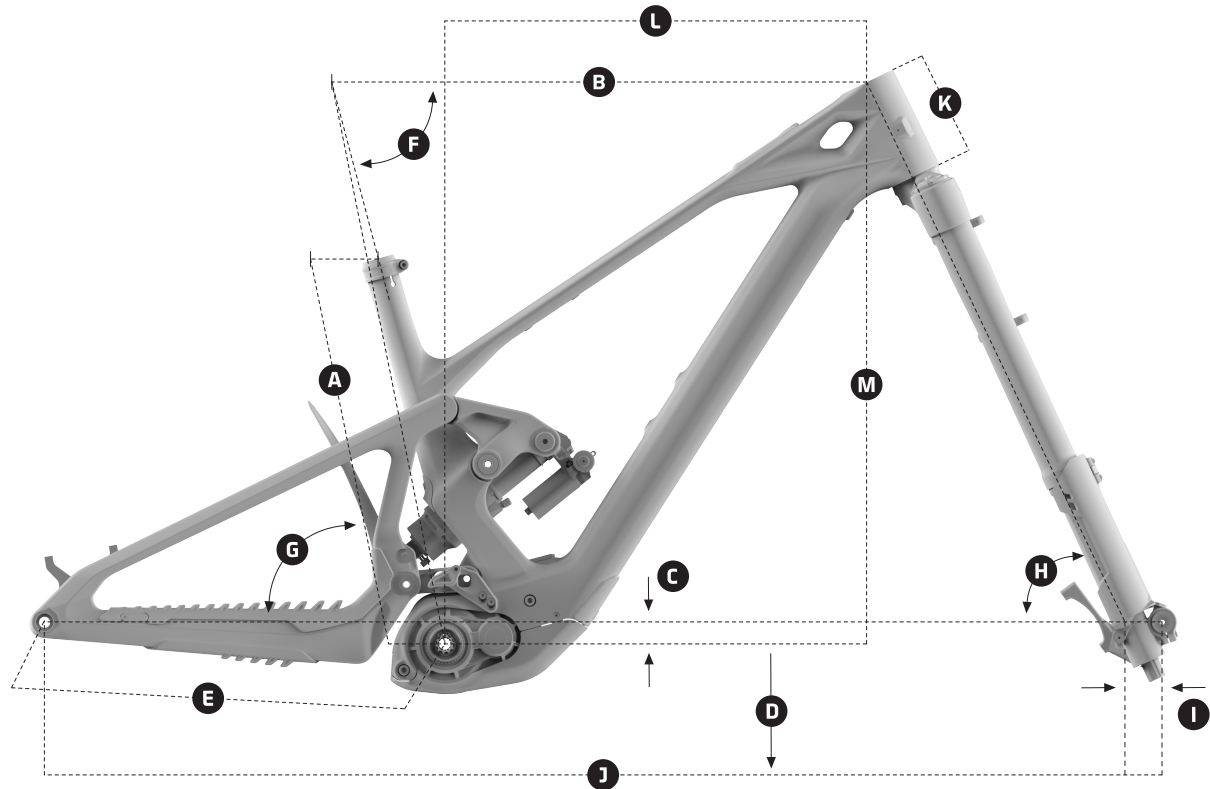

ZENDIT (FLIP CHIP POSIZIONE LOW)

DIMENSIONE DEL TELAIO	S	M	ML	L	XL
A Lunghezza Piantone	380 mm	410 mm	435 mm	460 mm	490 mm
B Lunghezza Tubo Orizz. Virtuale	586 mm	606 mm	629 mm	651 mm	673 mm
C BB Drop	11 mm	11 mm	11 mm	11 mm	11 mm
D Altezza movimento centrale	340 mm	340 mm	340 mm	340 mm	340 mm
E Lunghezza Batticatena	451 mm	451 mm	451 mm	456 mm	456 mm
F Angolo tubo sella	73,15°	73,15°	73,15°	73,15°	73,15°
G Angolo Sella	76,65°	76,65°	76,65°	76,65°	76,65°
H Angolo Sterzo	63,15°	63,15°	63,15°	63,15°	63,15°
I Offset Forcella / Rake	44 mm	44 mm	44 mm	44 mm	44 mm
J Interasse	1242 mm	1262 mm	1287 mm	1316 mm	1340 mm
K Lunghezza Tubo Sterzo	110 mm	110 mm	120 mm	130 mm	140 mm
L Reach	436 mm	456 mm	476 mm	496 mm	516 mm
M Stack	633 mm	634 mm	643 mm	652 mm	661 mm

* La lunghezza dei foderi orizzontali aumenta di 7 mm quando si monta una ruota posteriore da 29".



2. SPECIFICHE DEL TELAIO DELLA BICICLETTA

TAGLIE TELAIO	S / M / ML / L / XL
DIMENSIONE RUOTA ANTERIORE	29"
MOZZO ANTERIORE	110mm x 20mm (BOOST)
DIMENSIONE RUOTA POSTERIORE	27.5" / 29"
MOZZO POSTERIORE	148mm x 12mm (BOOST)
ASSE POSTERIORE	12X148 P1.0 L180
ATTACCHI PORTABORRACCE / RANGE EXTENDER	Tubo obliquo per portaborraccia, tubo orizzontale per accessori.
MOTORE	Avinox
MOVIMENTO CENTRALE	Avinox
BATTERIA	800Wh
RANGE EXTENDER	-
ESCURSIONE POSTERIORE	165mm
AMMORTIZZATORI POSTERIORI	205 x 65mm TRUNNION, 30 x 8mm
ESCURSIONE ANTERIORE	170mm
DIAMETRO REGGISELLA	31.6mm / 36.9mm
LINEA CATENA	55mm
STERZO	ZS56 / ZS56, 1-1/8", 1.5"
DIMENSIONE CORONA MASSIMA	36T
FRENO POSTERIORE	POST MOUNT, DIRECT 220mm max
DIMENSIONE MASSIMA RUOTA COMPATIBILE	29" x 2.6" (66-622)

3. PROFONDITÀ INSERIMENTO REGGISELLA

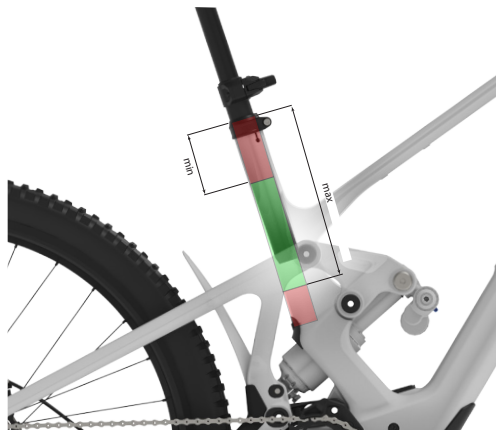

TAGLIA TELAIO	MIN. (mm)	MAX. (mm)
XL	100	300
L	100	270
ML	100	244
M	100	220
S	100	190



4. COMPONENTI TRASMISSIONE

4.1. GUIDA CATENA

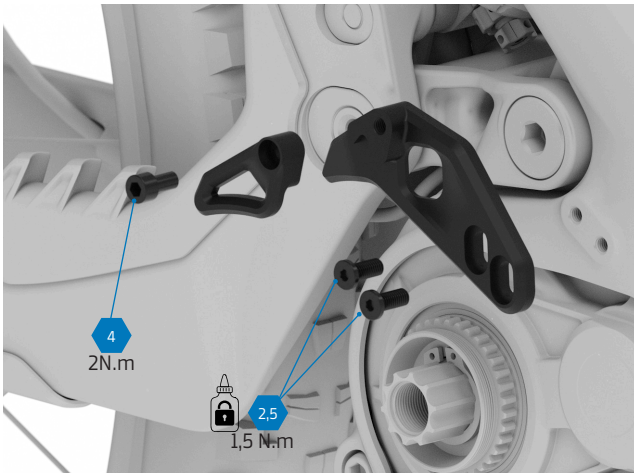

4.2. GUARNITURA

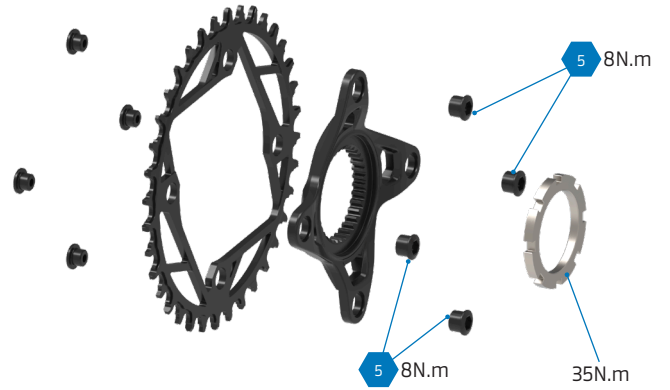

5. COPERCHIO MOTORE

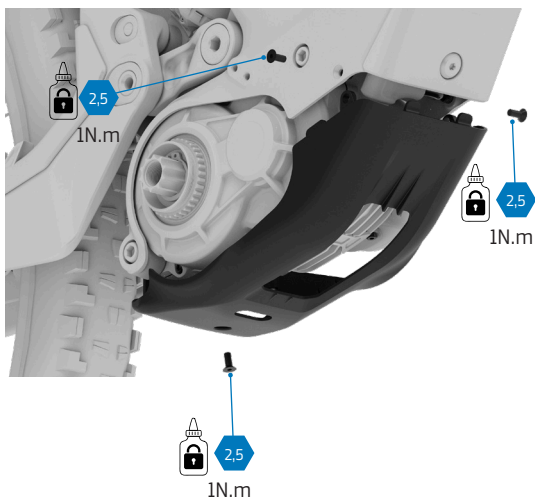



6. MOTORE

6.1. FISSAGGIO DEL MOTORE AL TELAIO

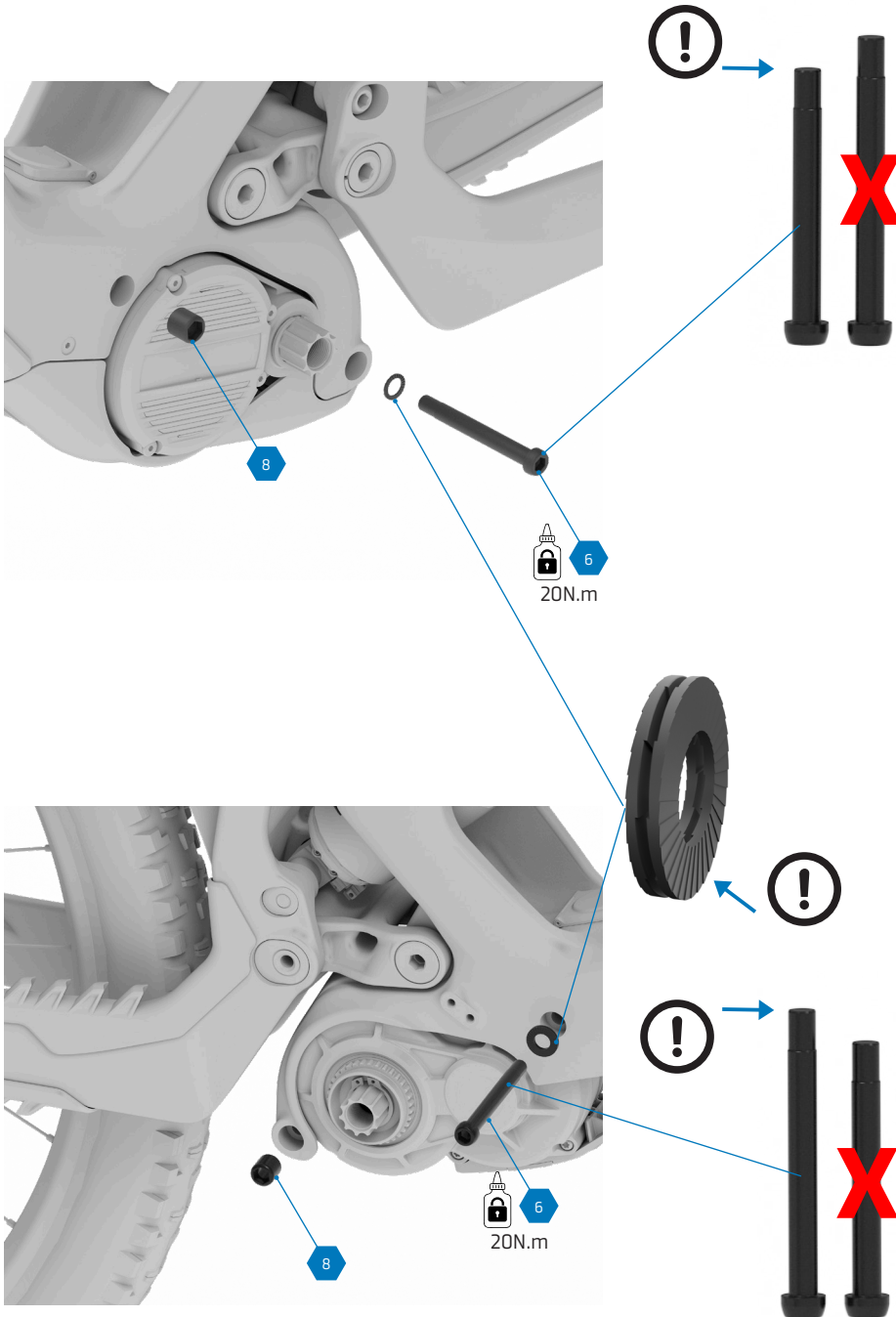

6. MOTORE

6.2. DISTANZIALI TRA IL TELAIO E IL MOTORE

Questo passaggio è necessario solo quando si sostituisce il motore o il telaio con uno nuovo. I motori e i telai assemblati in Mondraker sono già dotati dei distanziali corretti.

È necessario uno strumento speciale AVINOX per eseguire questa operazione.

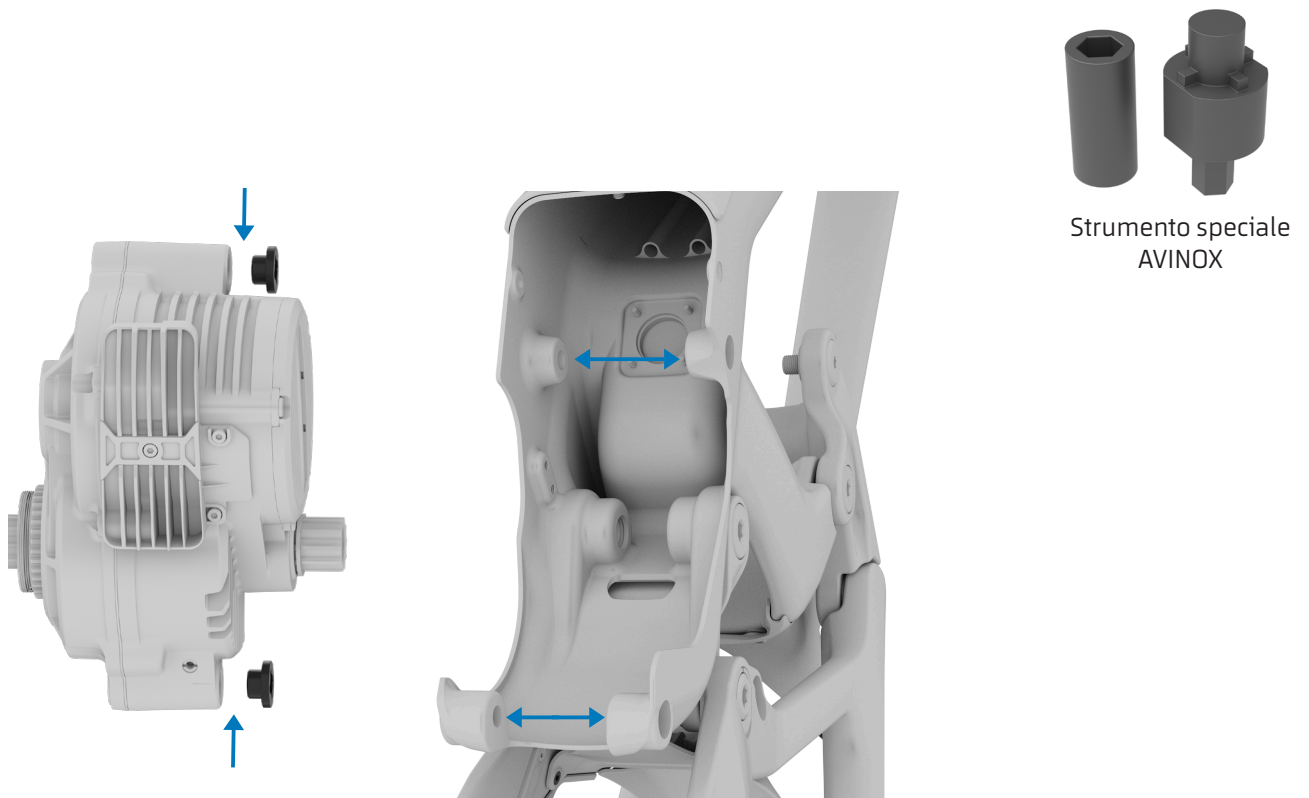

In caso di sostituzione del telaio o del motore, è necessario misurare con un calibro la distanza tra le superfici di appoggio in carbonio nell'alloggiamento del motore. In base a questa misura, occorre installare le relative rondelle o distanziali tra il motore e la vite, secondo i valori indicati nella tabella. È indispensabile verificare le misure sia nel punto di ancoraggio anteriore che in quello posteriore, in quanto possono differire e richiedere quindi un numero diverso di distanziali. Il serraggio finale delle viti deve essere effettuato utilizzando lo strumento speciale AVINOX, applicando una coppia di serraggio di **5 Nm**.

A = X - 56.7mm (Punto di ancoraggio anteriore) A = Y - 47.1mm (Punto di ancoraggio posteriore)

Gioco tra il telaio e il motore	Numero di rondelle del punto di montaggio
$A < 0.25\text{mm}$	0
$0.25\text{mm} \leq A < 0.50\text{mm}$	0
$0.50\text{mm} \leq A < 0.75\text{mm}$	2
$0.75\text{mm} \leq A < 1.00\text{mm}$	3
$A = 1.00\text{mm}$	4
$A > 1.00\text{mm}$	La tolleranza del telaio è anomala: l'unità di trasmissione non può essere installata.



7. PORTA DI RICARICA

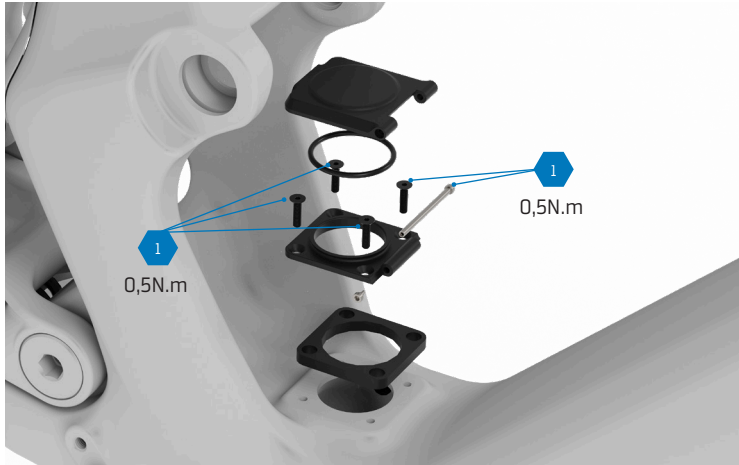

8. GUIDA INTERNA CAVI

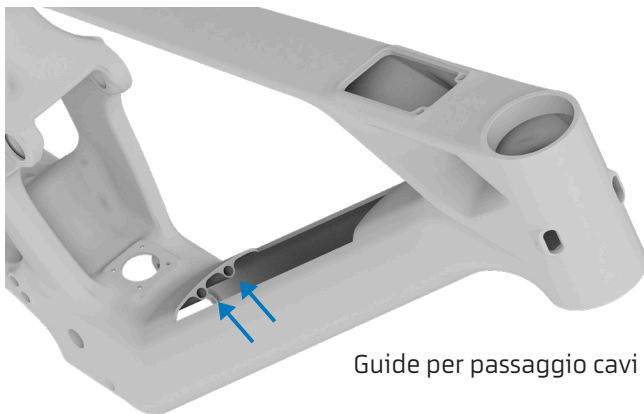
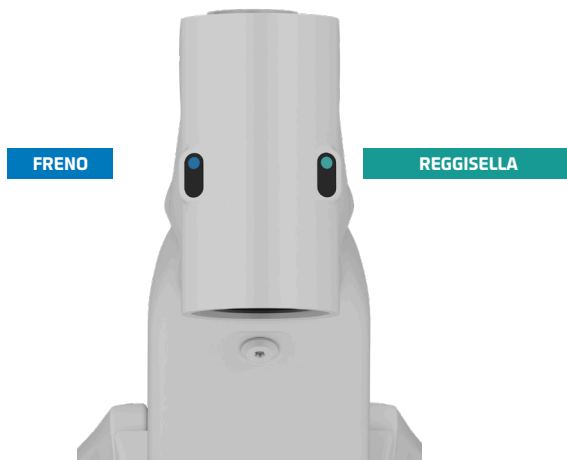

Guide per passaggio cavi interno



8. GUIDA INTERNA CAVI

8.1. INGRESSI DEI CAVI

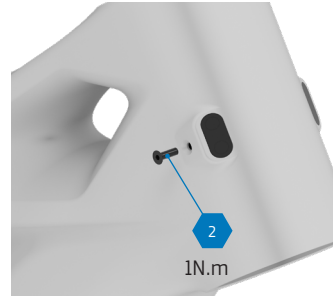
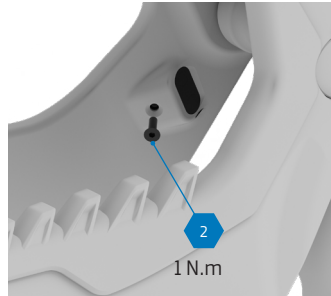
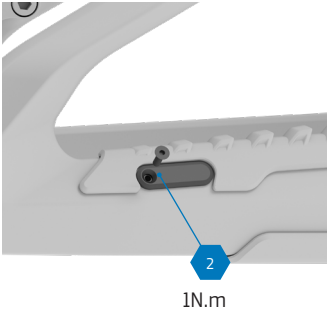

8.2. INGRESSO DEL SENSORE DI VELOCITÀ

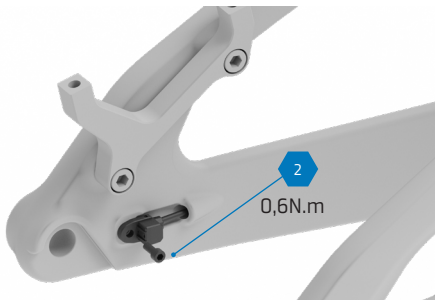

9. VITI DI FISSAGGIO DELLA BATTERIA

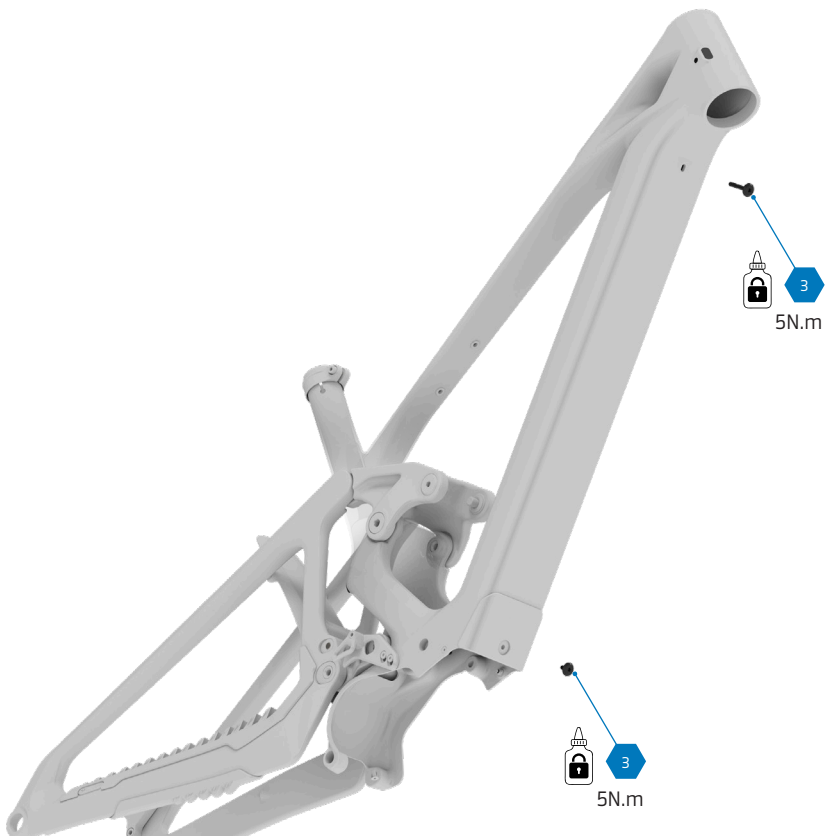



10. DISPLAY



11. COMANDO WIRELESS

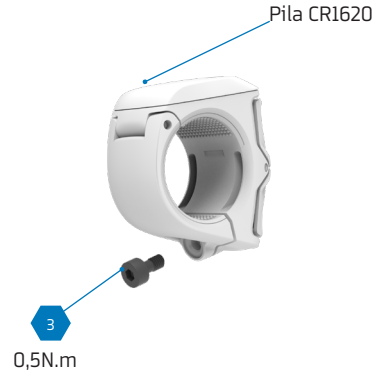

12. PARAFANGHI

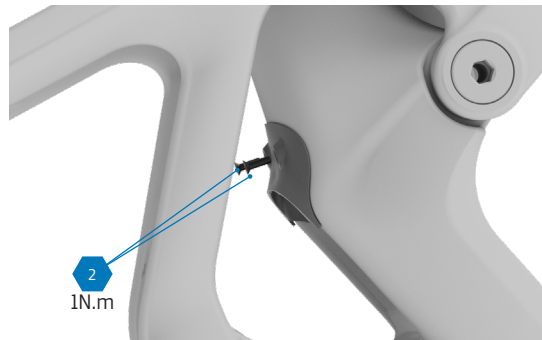
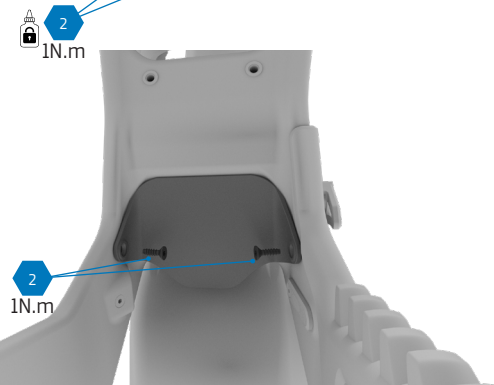
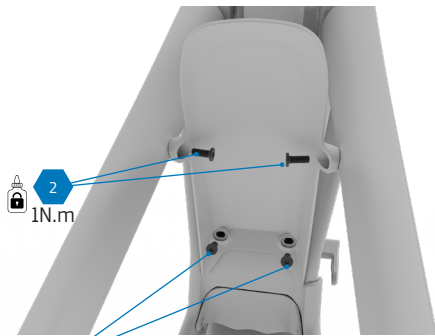

15. COLLARINO SELLA



Si raccomanda di utilizzare grasso a frizione per carbonio sul reggisella

16. GUIDA ALL'INSTALLAZIONE DEL LEVERAGGIO SUPERIORE



Utilizzare Loctite 243 per la filettatura.



Consiglio da Pro: Invece di applicare il frenafiletti sulla vite, puoi metterlo direttamente nella filettatura interna del telaio della bicicletta. In questo modo si evita di contaminare gli altri componenti con il frenafiletti durante l'inserimento della vite.

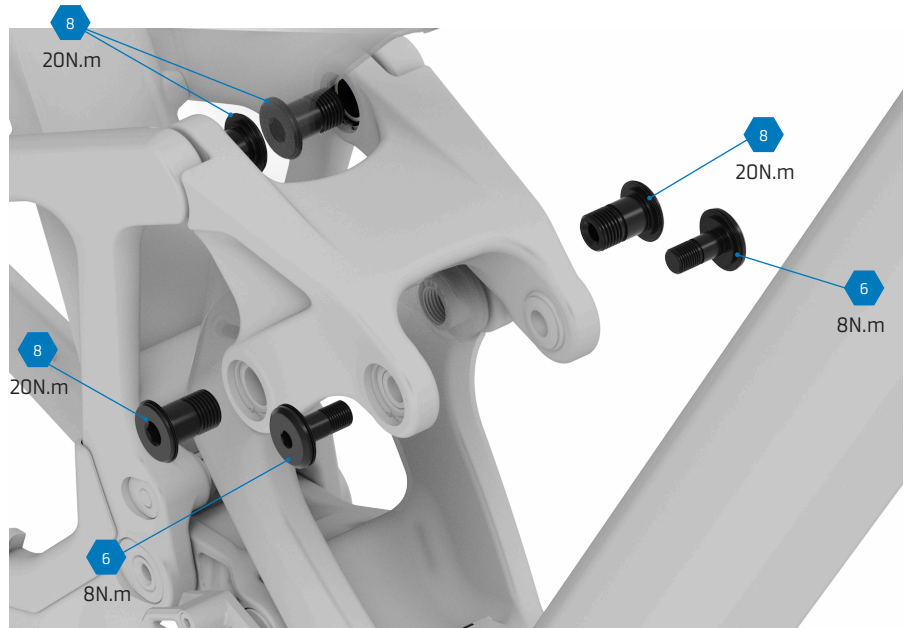
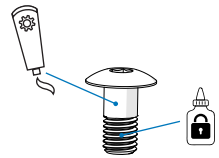

Per le viti principali applicare grasso all'albero e Loctite 243 alle filettature.

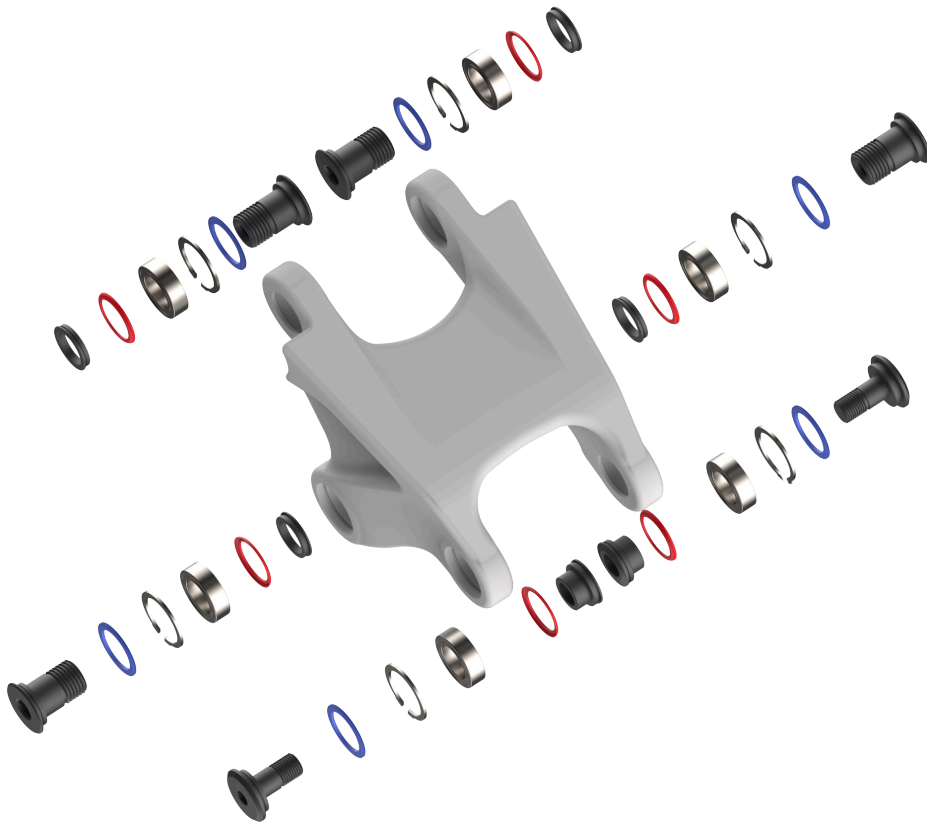

Prestare particolare attenzione alla posizione delle guarnizioni in gomma.



Applicare grasso sulle zone di attrito evitando di contaminare le parti filettate.

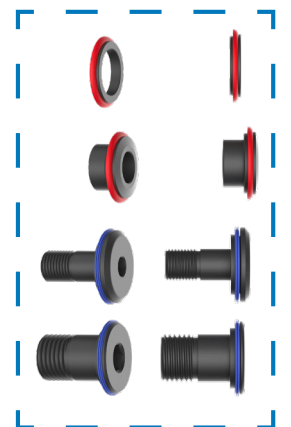



17. GUIDA ALL'INSTALLAZIONE DELLA BIELLETTA INFERIORE

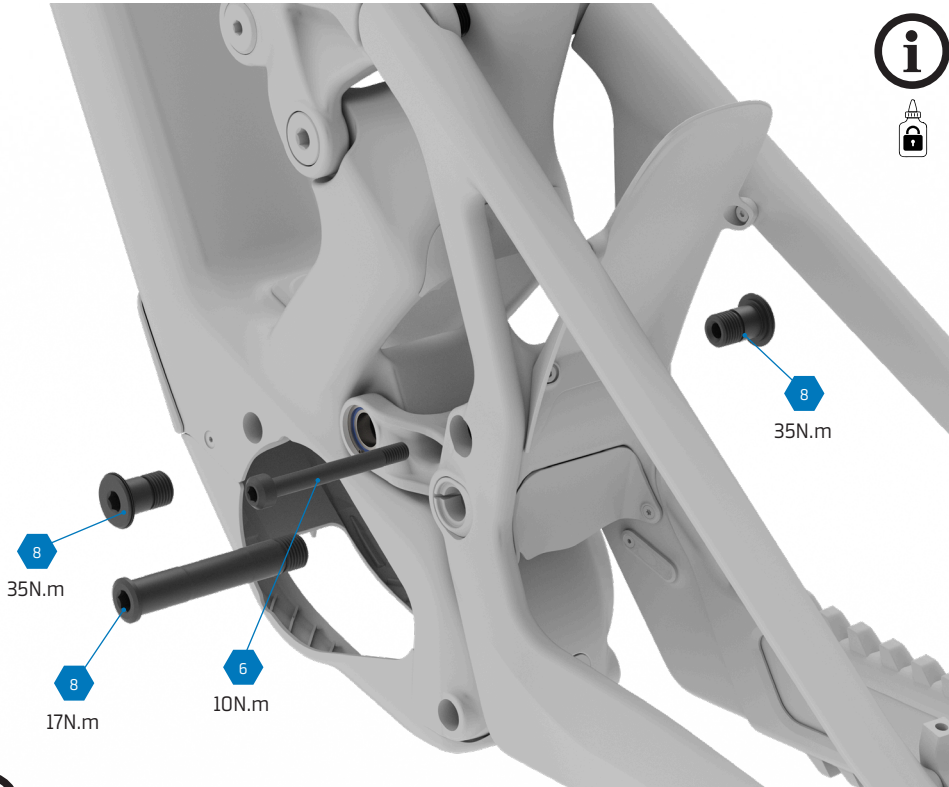

Utilizzare Loctite 243 per la filettatura.



Consiglio da Pro: Invece di applicare il frenafili sulla vite, puoi metterlo direttamente nella filettatura interna del telaio della bicicletta. In questo modo si evita di contaminare gli altri componenti con il frenafili durante l'inserimento della vite.

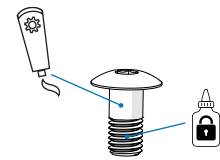

Per le viti principali applicare grasso all'albero e Loctite 243 alle filettature.

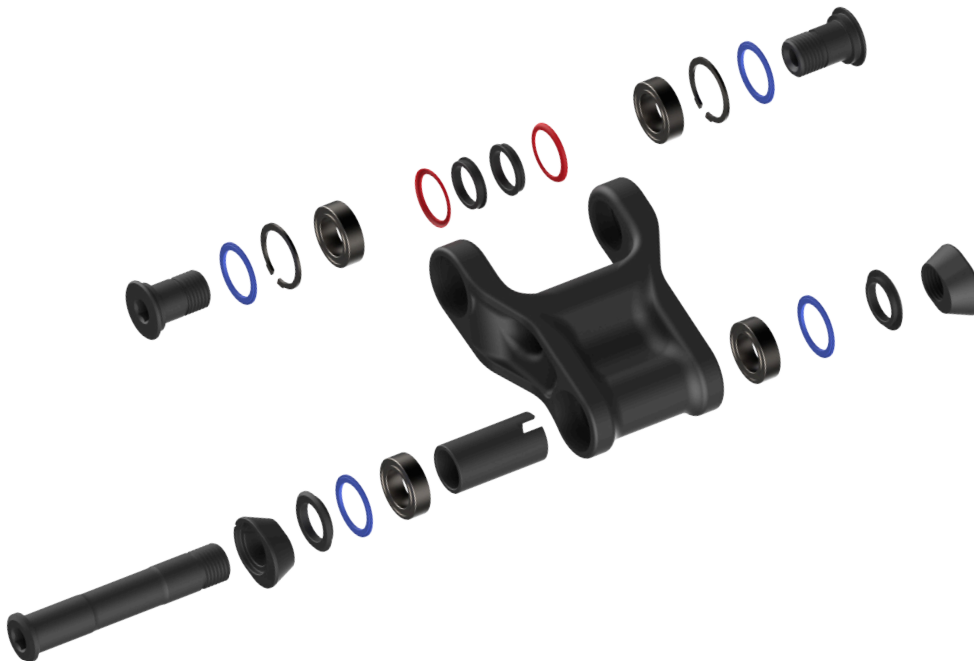

Prestare particolare attenzione alla posizione delle guarnizioni in gomma.



Applicare grasso sulle zone di attrito evitando di contaminare le parti filettate.

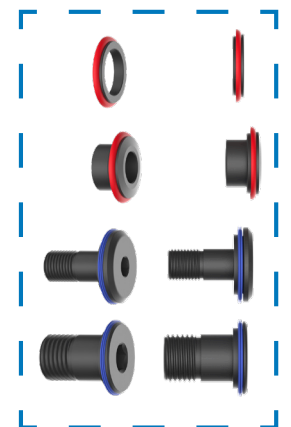



18. FLIP CHIP

18.1 FLIP CHIP PER CAMBIO FORMATO RUOTA 27.5"-29"

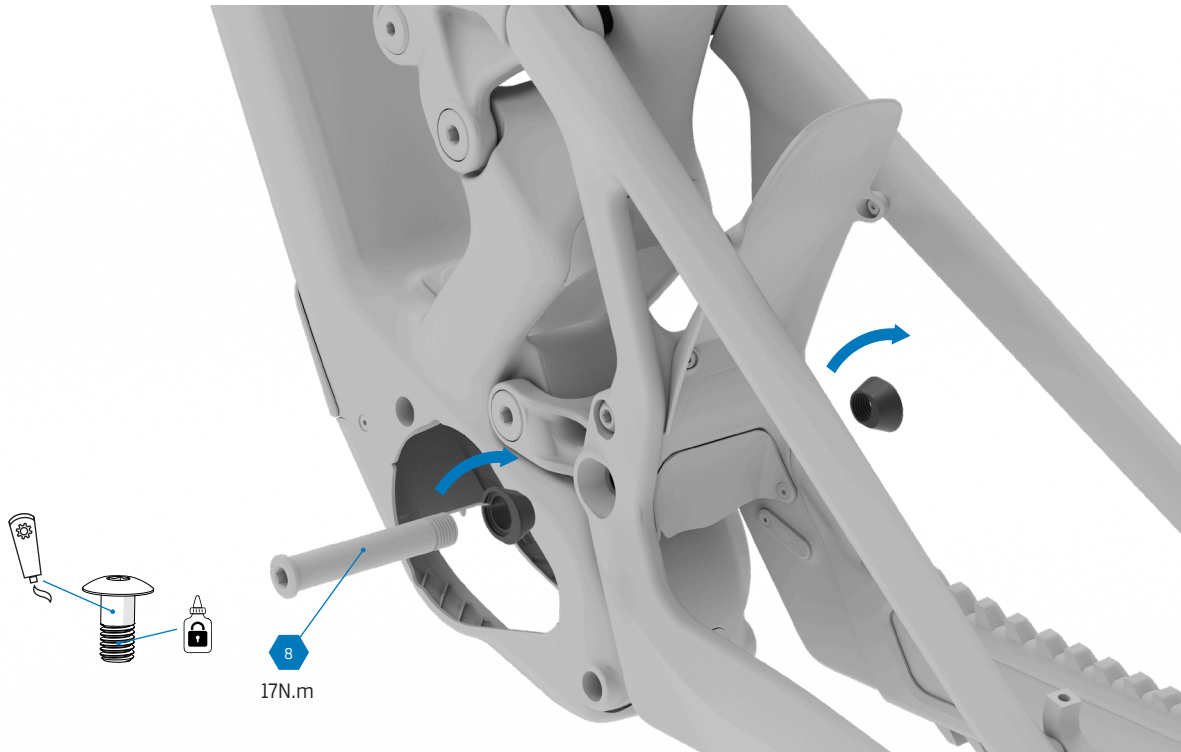

- ❗ Per le viti principali applicare grasso all'albero e Loctite 243 alle filettature.
- ❗ Applicare grasso sulle zone di attrito evitando di contaminare le parti filettate.
- ❗ Quando si passa dalle ruote da 27,5" a quelle da 29", assicurarsi di aggiungere 2 maglie extra alla lunghezza della catena. Con le 27,5" la catena ha 120 maglie, con le 29" ne ha 122. È inoltre necessario connettere l'applicazione Avinox Ride e aggiornare le impostazioni del wheel set-up.

18.2 FLIP CHIP PER CAMBIO CINEMATICA STD - LOW

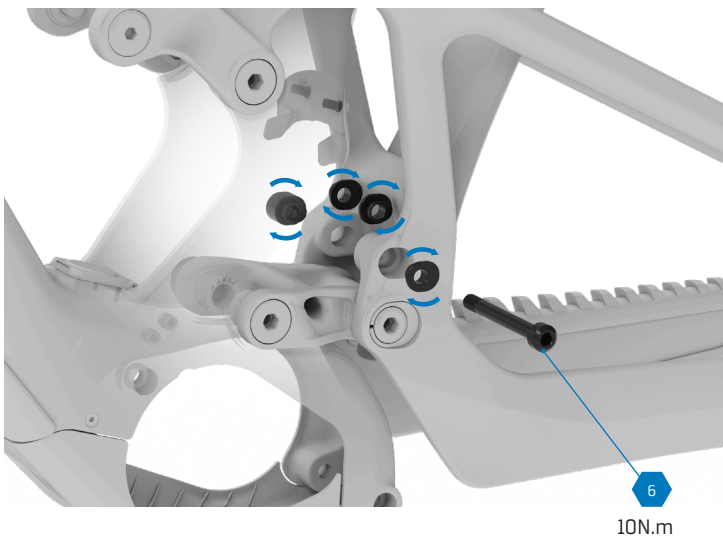

Il flip chip per il cambio di cinematica è composto da 4 pezzi: 2 esterni e 2 interni.



20. SPARE PARTS
ZENDIT

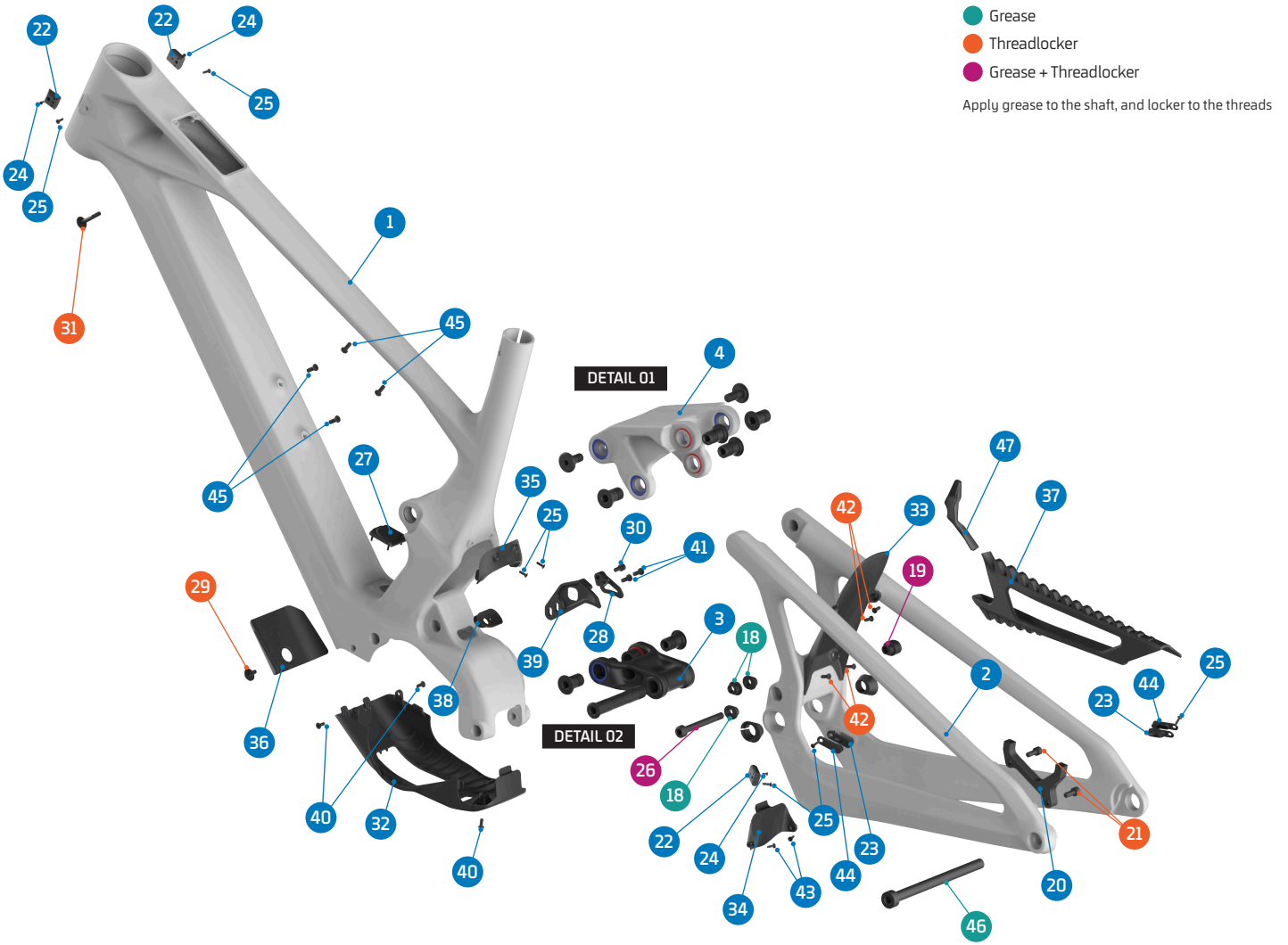

ITEM No.	DESCRIPTION	QTY.	PART NUMBER	TORQUE
1	FRAME	1		
2	REAR TRIANGLE	1		
3	LOWER LINK	1	099.26038	
4	UPPER LINK	1	Refer to B2B web for color options	
5	BEARING, 24x15x7 (3802-2RS)	10	SET 1 / 099.00113	
6	PIVOT WASHER	6	SET 3 & 4	
7	PIVOT SEAL, INTERNAL	8	SET 2, 3, 4 & 8	
8	PIVOT SEAL, EXTERNAL	10	SET 2, 3, 4 & 8	
9	PIVOT AXLE, M15	6	SET 3 & 4	35Nm / 20Nm
10	C-RING	8	SET 2, 3 & 4	
11	SPACER, 38L	1	SET 4	
12	SPACER, LOWER	2	SET 4	
13	PIVOT CHIP, LEFT	1	SET 4 & 099.26049	
14	PIVOT CHIP, RIGHT	1	SET 4 & 099.26050	
15	PIVOT AXLE, 81L	1	SET 4	17Nm
16	SPACER, 10x17x6	2	SET 2	
17	SHOCK BOLT	2	SET 2	8Nm
18	SHOCK FLIP CHIP LEFT	3	099.26044	
19	SHOCK FLIP CHIP RIGHT	1	099.26045	
20	DISC MOUNT	1	SET 6	
21	SCREW BOLT, M6x15	2	SET 6	12Nm
22	CABLE GUIDE	3	SET 7	
23	CABLE GUIDE	2	099.26046	
24	SCREW BOLT, M2,5x5	3	SET 7	1Nm

ITEM No.	DESCRIPTION	QTY.	PART NUMBER	TORQUE
25	SCREW BOLT, M3x10	7	SET 7 & 099.20068	1Nm
26	SHOCK BOLT, 70L	1	SET 2 & 099.26051	10Nm
27	CHARGE PORT COVER	1	099.26052	
28	CHAIN GUIDE OUTER	1	SET 5	
29	SCREW BOLT, M5x10	1	SET 9	5Nm
30	SCREW BOLT, M5x8	1	SET 9	2Nm
31	SCREW BOLT, M5x30	1	SET 9	5Nm
32	MOTOR COVER	1	099.26054	
33	TYRE FENDER	1	099.26055	
34	YOKE FENDER	1	099.26056	
35	FRONT FENDER	1	099.26057	
36	DOWN TUBE PROTECTOR	1	099.20058	
37	CHAINSTAY PROTECTOR	1	099.26059	
38	RUBBER CABLE PROTECTOR	1	099.26060	
39	CHAIN GUIDE BASE PLATE	1	SET 5	
40	SCREW BOLT, M4x10	3	099.26061	2Nm
41	SCREW BOLT, M5x12	2	SET 5	1,5Nm
42	SCREW BOLT, M4x10	4	099.20078	1Nm
43	SCREW BOLT, M3x10	2	099.26063	1Nm
44	CABLE GUIDE, COVER	2	099.26047	
45	SCREW BOLT, M5x8	4		1Nm
46	REAR AXLE	1	112.90027	
47	CHAINSTAY YOKE PROTECTOR	1	099.26109	



20. SPARE PARTS
ZENDIT



DETAIL 01

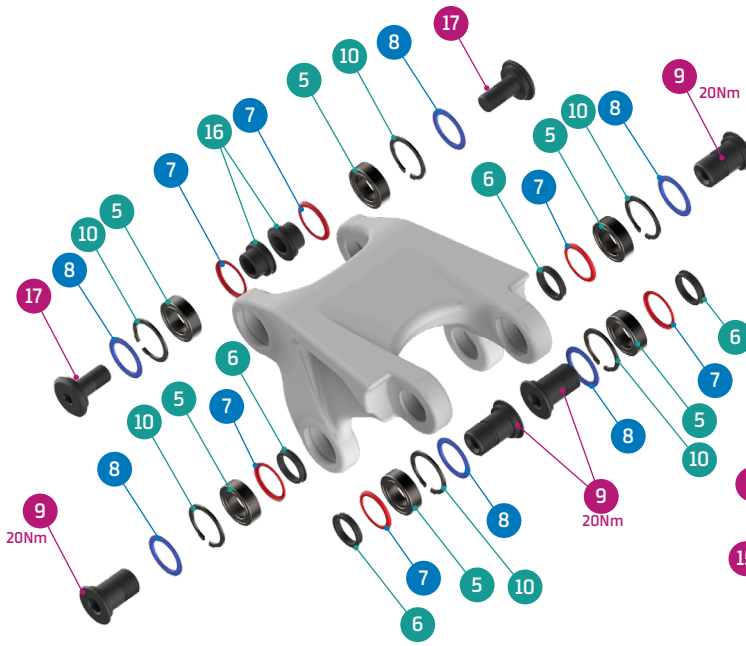

DETAIL 02

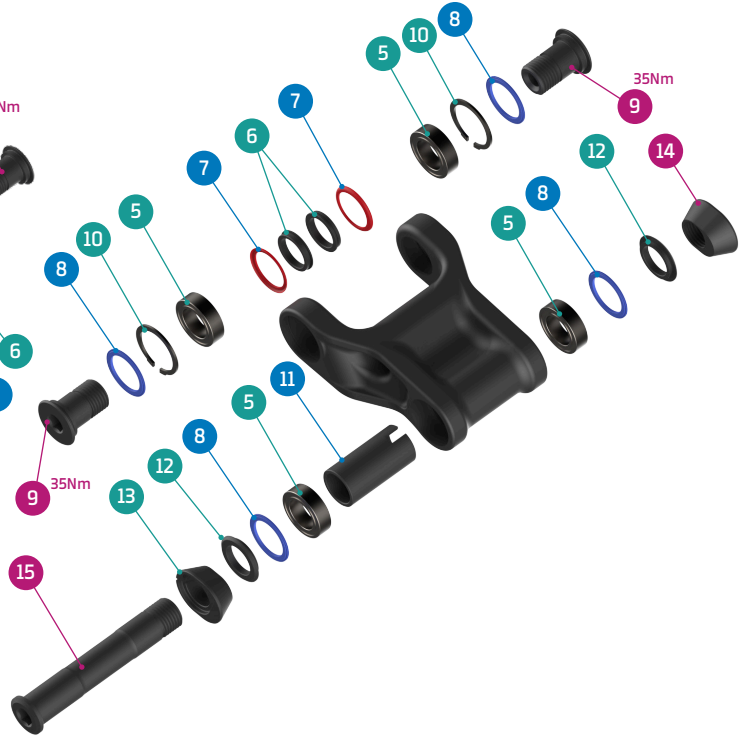

SET 6	SET 7	SET 8	SET 9
DISC ADAPTOR KIT	CABLE GUIDE KIT	SEALS KIT	BATTERY BOLTS KIT

SET 1	SET 2	SET 3	SET 4	SET 5
ZERO BEARING KIT 25	SHOCK HARDWARE KIT 23	UPPER LINK KIT 34	LOWER LINK KIT 38	CHAIN GUIDE PLATE + BOLTS

PART NUMBER	DESCRIPTION	COMPONENTS
099.22100	SET 1: ZERO BEARING KIT 25	BEARING 3802-2RS, 24x15x7 (x10)
099.26201	SET 2: SHOCK HARDWARE KIT 23	PIVOT SEAL INTERNAL (x2) / PIVOT SEAL EXTERNAL (x2) / C-RING (x2) / SPACER, 10x17x6 (x2) / SHOCK BOLT (x2) / SHOCK BOLT, 70 (x1)
099.26300	SET 3: UPPER LINK KIT 34	PIVOT WASHER (x4) / PIVOT SEAL INTERNAL (x4) / PIVOT SEAL EXTERNAL (x4) / PIVOT AXLE, M15 (x4) / C-RING (x4)
099.26400	SET 4: LOWER LINK KIT 38	PIVOT WASHER (x2) / PIVOT SEAL INTERNAL (x2) / PIVOT SEAL EXTERNAL (x4) / PIVOT AXLE, M15 (x2) / C-RING (x2) / SCPACER, 38 (x1) / SCPACER LOWER (x1) / PIVOT CHIP LEFT (x1) / PIVOT CHIP RIGHT (x1) / PIVOT AXLE, 81 (x1)
099.26064	SET 5: CHAIN GUIDE PLATE + BOLTS	CHAIN GUIDE BASE (x1) / CHAIN GUIDE OUTER PLATE (x1) / SCREW BOLT, M5X12 (x2) / SCREW BOLT, M5x10 (x1)
099.25018	SET 6: DISC ADAPTOR KIT	DISC ADAPTOR (x1) / SCREW BOLT (x2)
099.26048	SET 7: CABLE GUIDE KIT	CABLE GUIDE (x1) / SCREW BOTL M2.5X5L (x1) / SCREW BOLT M3X10L (x1)
099.26062	SET 8: SEALS KIT	PIVOT SEAL INTERNAL (x8) / PIVOT SEAL EXTERNAL (x10)
099.26053	SET 9: BATTERY BOLTS KIT	SCREW BOLT, M5x10 (x1) / SCREW BOLT, M5x30 (x1)



21. FAQs

POSSO UTILIZZARE UNA RUOTA POSTERIORE DA 29"? DEVO MODIFICARE QUALCOSA SULLA BICI?

Per configurare la Zendit con una ruota posteriore da 29" è sufficiente modificare la posizione del flip chip sul link inferiore. La lunghezza del carro aumenta di 7 mm rispetto alla configurazione mullet standard, mentre lo spazio disponibile e la posizione della pinza freno rimangono invariati. La bici viene fornita di serie in configurazione mullet. Prima di utilizzare una ruota posteriore da 29", è necessario aggiornare la configurazione tramite l'app Avinox Ride.

PREFERISCO UTILIZZARE UNA CONFIGURAZIONE FULL 29". PERCHÉ ZENDIT È PROPOSTA DI SERIE IN MULLET?

La configurazione mullet (29" anteriore / 27.5" posteriore) consente una guida più agile e precisa, indipendentemente dal livello del rider o dalla taglia della bici. Se si desidera utilizzare una ruota posteriore da 29", il sistema flip chip consente di modificare facilmente la configurazione senza alterare geometria o cinematica della sospensione. La lunghezza del carro aumenta di 7 mm. In questo caso è necessario aggiungere 2 maglie alla catena, passando da 120 a 122 maglie. Tutti i modelli Zendit sono equipaggiati di serie con trasmissione SRAM T-Type.

QUANTO PESA IL TELAIO DELLA NUOVA ZENDIT?

Il telaio Stealth Air Carbon utilizzato sui modelli Zendit RR, RR S e XR è identico per tutte le versioni e pesa esattamente 3.000 grammi (taglia ML verniciata, hardware incluso, senza ammortizzatore posteriore).

QUALI AMMORTIZZATORI SONO COMPATIBILI CON ZENDIT?

Oltre agli ammortizzatori Fox Float X e Fox Float X2 che montiamo sui diversi modelli Zendit, la bicicletta è compatibile anche con la serie Fox DHX a molla, Öhlins TTX ad aria o TTX22 m.2 a molla, e RockShox a molla o ad aria (eccetto i modelli Vivid Air e Vivid Coil che non sono compatibili con i telai di taglia S e M). La Zendit monta ammortizzatori metrici da 205 x 65 mm con attacco superiore Trunnion e hardware standard inferiore da 30x8 mm. Controllare prima di installare qualsiasi altro ammortizzatore posteriore più grande perché potrebbe non adattarsi, in quanto il serbatoio (piggyback) potrebbe urtare il tubo principale alla massima compressione.

I NUOVI MOZZI DT SWISS DEG SONO DISPONIBILI SU ZENDIT?

Sì. I modelli Zendit RR S e XR sono equipaggiati con mozzi DT Swiss DEG DF con tecnologia anti pedal kickback, specifica per e-bike, con possibilità di impostazione del movimento del corpetto libero a 0° o 10°. Le bici vengono fornite di serie con il corpetto impostato sulla posizione 10°.

QUALI AGGIORNAMENTI INTRODUCE LA CINEMATICA DELLA NUOVA ZENDIT?

Zendit introduce un'evoluzione del sistema Zero Suspension con una cinematica aggiornata. La nuova configurazione prevede:

- una progressione della sospensione posteriore pari al 25,7%
- un leverage ratio più elevato
- una maggiore sensibilità nella fase iniziale
- valori di anti-squat e anti-rise leggermente ridotti

La lunghezza e la corsa dell'ammortizzatore sono state aggiornate a 205 × 65 mm.

Sag consigliato: circa 28% (18 mm)

Sag massimo consigliato: 33% (21,5 mm)



21. FAQs

QUAL È LA CORSA MASSIMA DELLA FORCELLA COMPATIBILE CON ZENDIT?

Zendit è compatibile con forcelle fino a 180 mm di escursione o 600 mm axle-to-crown. Tuttavia, non si consiglia l'utilizzo di configurazioni diverse da quella di serie da 170 mm, per mantenere geometria e bilanciamento ottimali.

È POSSIBILE UTILIZZARE UN DISCO FRENO POSTERIORE DA 220 MM SU ZENDIT?

Sì. Zendit è compatibile con dischi posteriori fino a 220 mm. Tuttavia, considerando la potenza dei sistemi frenanti moderni, non si tratta di una configurazione raccomandata.

ZENDIT DISPONE DI DUE POSIZIONI DI GEOMETRIA. COME FUNZIONA?

Zendit offre due posizioni di geometria tramite flip chip:

- posizione Standard (configurazione di serie)
- posizione Low

In posizione Low:

- il movimento centrale si abbassa di 5 mm
- l'angolo di sterzo varia di $-0,35^\circ$

La regolazione si effettua svitando il bullone inferiore dell'ammortizzatore e ruotando gli inserti del flip chip.

QUAL È LA LARGHEZZA MASSIMA DEGLI PNEUMATICI COMPATIBILI CON ZENDIT?

Zendit è compatibile con pneumatici fino a 66 mm di larghezza, equivalenti a:

- 27.5 × 2.6"
- 29 × 2.6"

Si consiglia di verificare la larghezza reale del pneumatico prima dell'installazione.

È POSSIBILE INSTALLARE UN RANGE EXTENDER PER AUMENTARE L'AUTONOMIA?

No. Zendit utilizza esclusivamente la batteria interna da 800 Wh e non è previsto alcun range extender.

È POSSIBILE MONTARE UN PORTABORRACCIA?

Sì. Sono disponibili due posizioni per il portaborraccia:

- all'interno del triangolo principale
- sotto il tubo superiore

Il passaggio cavi entra dal tubo di sterzo. È possibile far passare i cavi internamente?

Sì. La serie sterzo è predisposta per consentire il passaggio interno dei cavi.



21. FAQs

È POSSIBILE SMONTARE LA BATTERIA INTERNA?

La batteria può essere rimossa solo dopo aver smontato il motore. Questa operazione deve essere eseguita esclusivamente da un meccanico qualificato presso un rivenditore autorizzato. Non è raccomandato lo smontaggio della batteria.

QUANTO TEMPO SERVE PER RICARICARE COMPLETAMENTE LA BATTERIA?

Con caricatore rapido (modello XR):

- 0 → 75% in 1 h 30 min
- 0 → 100% in 2 h 25 min

Con caricatore standard (modelli RR S e RR):

- 0 → 75% in 4 h 28 min
- 0 → 100% in 5 h 10 min

I CAMBI SRAM T-TYPE POSSONO ESSERE COLLEGATI ALLA BATTERIA DELLA BICI?

Sì. Questa funzione è disponibile di serie su tutti i modelli Zendit. Il sistema consente la funzione SmoothShift, che permette il cambio marcia anche senza pedalare.

È possibile utilizzare una trasmissione Shimano su Zendit?

Sì. È sufficiente utilizzare un forcellino UDH compatibile con deragliatore Shimano.

Qual è il livello massimo di assistenza del motore Avinox M2S?

Il livello massimo di assistenza è pari a:

- 800%
- 150 Nm
- 1300 W in modalità Boost

È POSSIBILE PERSONALIZZARE LE MODALITÀ DI ASSISTENZA?

Sì. Le modalità di assistenza possono essere personalizzate tramite il display o l'app Avinox Ride. Ulteriori informazioni sono disponibili sul sito Avinox.

QUALE AUTONOMIA È POSSIBILE OTTENERE CON ZENDIT?

L'autonomia dipende da diversi fattori, tra cui modalità di assistenza, peso del rider e terreno. Indicativamente, con batteria da 800 Wh, un rider di 80 kg può affrontare circa 2000 m di dislivello e pedalare fino a 4 ore utilizzando principalmente le modalità Auto ed Eco.



21. FAQs

QUALI INFORMAZIONI FORNISCE IL DISPLAY ZENDIT?

Tutte le informazioni relative al display e al controller sono disponibili sul sito Avinox.

CHE TIPO DI MANUTENZIONE RICHIEDE IL MOTORE AVINOX M2S?

Non è richiesta alcuna manutenzione specifica. È importante evitare l'utilizzo di sistemi di lavaggio ad alta pressione nella zona del motore e dei componenti elettronici.

QUALE TAGLIA DI BICICLETTA MI SERVE?

I modelli Zendit sono disponibili in 5 taglie, con una taglia ML posizionata tra la Medium y la Large. Rispetto all'opzione a 4 taglie offerta su altri modelli Mondraker, le nuove taglie Small e Medium sono leggermente più piccole rispetto alle precedenti, mentre las nuove Large ed Extra Large sono leggermente più grandi. Consulta le tabelle delle geometrie per ulteriori informazioni e dettagli. Di seguito, una panoramica delle taglie consigliate in base all'altezza del rider.

<165 cm	165-170 cm	170-175 cm	175-180 cm	180-185 cm	185-190 cm	190-195 cm	>195 cm
S		M/L				XL	
	M			L			



Tutte le informazioni e le immagini contenute in questo documento sono fornite esclusivamente a titolo informativo e non costituiscono un contratto legale tra MONDRAKER e qualsiasi persona o entità. Le specifiche, le geometrie o qualsiasi altra informazione tecnica qui pubblicata sono soggette a modifiche senza preavviso.

© ® Tutti i marchi e modelli sono di proprietà di Blue Factory team, S.L.U. e sono protetti dalle leggi vigenti e dagli accordi internazionali applicabili.

MANUALES Y DOCUMENTOS



INSTRUCCIONES GENERALES Y DE SEGURIDAD

En esta guía técnica pueden aparecer los 3 iconos siguientes. Cada uno de ellos indica que deben tomarse las siguientes precauciones:

ADVERTENCIA:

No seguir las indicaciones o usar la bicicleta de forma inadecuada puede ocasionar graves lesiones o incluso la muerte. Estas tareas entrañan dificultad técnica y, si no se realizan de forma adecuada, podrían causar daños a tu bicicleta o dar lugar a la anulación de la garantía.

CUIDADO:

No seguir las indicaciones o usar la bicicleta de forma inadecuada puede ocasionar lesiones leves. Estas tareas entrañan dificultad técnica y, si no se realizan de forma adecuada, podrían causar daños a tu bicicleta o dar lugar a la anulación de la garantía.

INFORMACIÓN

Información imprescindible para realizar esta tarea correctamente y, así, evitar que se cause cualquier daño a la bicicleta o se pierda la garantía, pero que no supone ningún riesgo para las personas.

OTRAS CONSIDERACIONES

- El uso de piezas de repuesto no originales puede ocasionar daños, fallos de funcionamiento y accidentes que pueden tener graves consecuencias.
- Para realizar algunos de los pasos descritos en este manual se requieren habilidades superiores a las del usuario medio de bicicleta. En caso de no poder seguir alguno de estos pasos, lleva tu bicicleta a un servicio técnico autorizado Mondraker para el mantenimiento y sustitución de sus componentes. La instalación incorrecta de piezas de repuesto puede ocasionar fallos de funcionamiento, accidentes, lesiones y la anulación de la garantía.

LIMPIEZA Y CUIDADO

- Una vez desmontadas las piezas, se recomienda limpiar, engrasar y poner fijador de roscas (en caso necesario) en los componentes que se vayan a reutilizar.

LEYENDA DE SÍMBOLOS



Fijador de roscas grado medio. Loctite 243.



Grasa sintética de calidad para montaje.



Grasa especial de fricción para carbono.

1. GEOMETRÍA

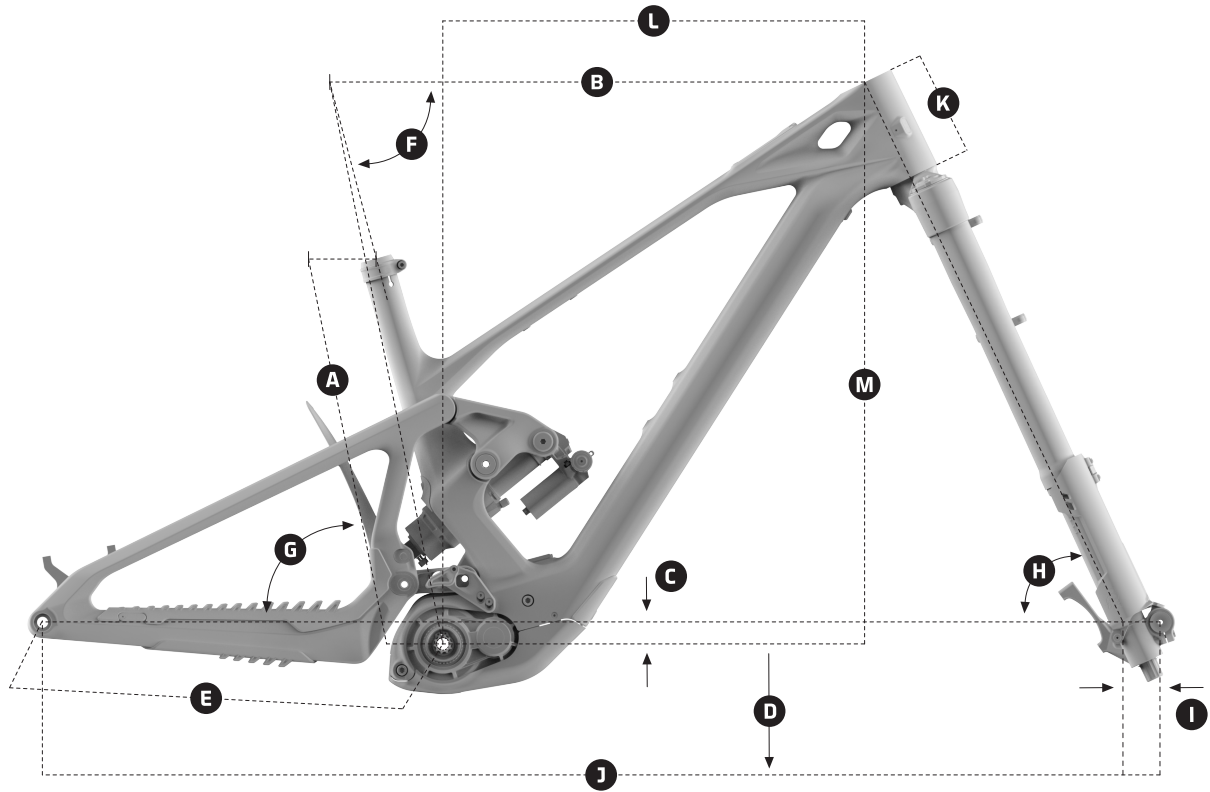

ZENDIT (FLIP CHIP POSICIÓN ESTÁNDAR)

TALLA DE CUADRO	S	M	ML	L	XL
A Longitud tubo sillín	380 mm	410 mm	435 mm	460 mm	490 mm
B Longitud tubo superior	586 mm	606 mm	628 mm	650 mm	672 mm
C Caída eje pedalier	6 mm	6 mm	6 mm	6 mm	6 mm
D Altura eje pedalier	345 mm	345 mm	345 mm	345 mm	345 mm
E Longitud vainas	450 mm	450 mm	450 mm	455 mm	455 mm
F Ángulo tubo sillín real	73,5°	73,5°	73,5°	73,5°	73,5°
G Ángulo tubo sillín efectivo	77,0°	77,0°	77,0°	77,0°	77,0°
H Ángulo dirección	63,5°	63,5°	63,5°	63,5°	63,5°
I Offset de la horquilla	44 mm	44 mm	44 mm	44 mm	44 mm
J Distancia entre ejes	1241 mm	1261 mm	1286 mm	1315 mm	1339 mm
K Longitud pipa	110 mm	110 mm	120 mm	130 mm	140 mm
L Reach	440 mm	460 mm	480 mm	500 mm	520 mm
M Stack	631 mm	631 mm	640 mm	649 mm	658 mm

* La longitud de las vainas aumenta 7 mm al montar una rueda trasera de 29".

1. GEOMETRÍA

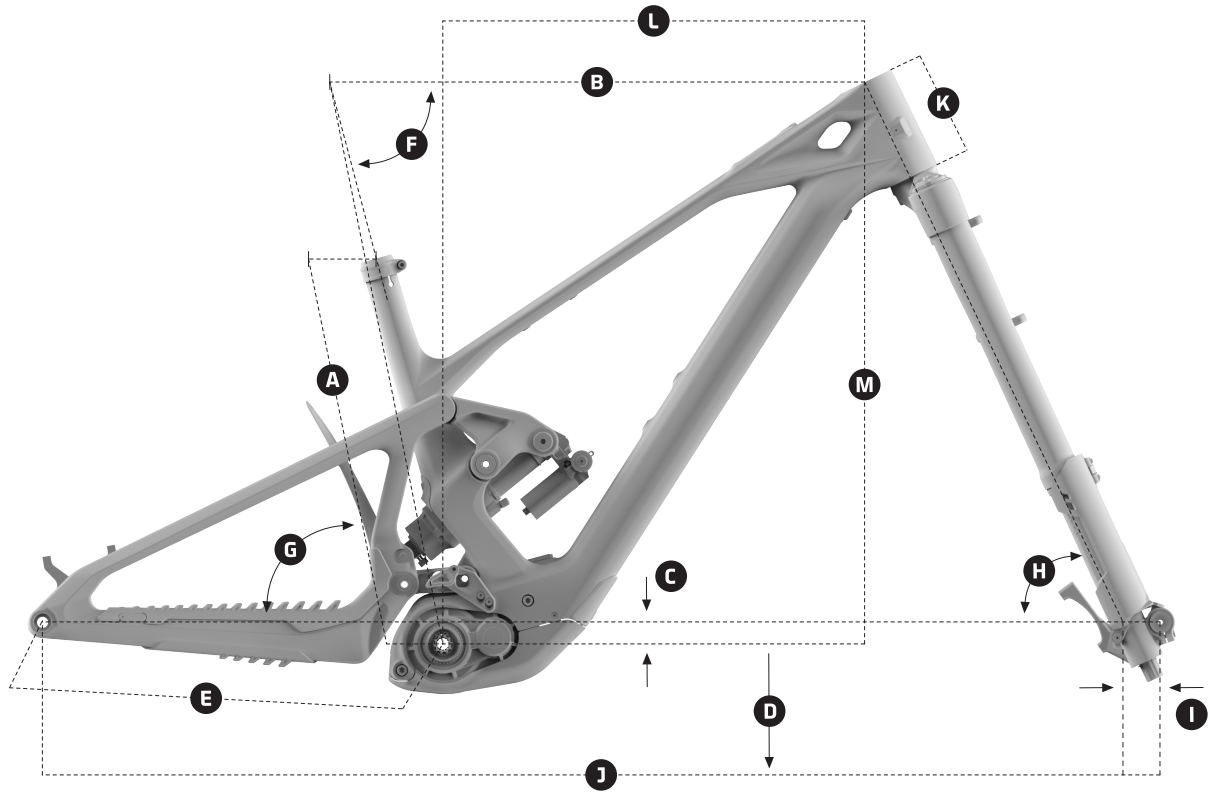

ZENDIT (FLIP CHIP POSICIÓN LOW)

TALLA DE CUADRO	S	M	ML	L	XL
A Longitud tubo sillín	380 mm	410 mm	435 mm	460 mm	490 mm
B Longitud tubo superior	586 mm	606 mm	629 mm	651 mm	673 mm
C Caída eje pedalier	11 mm	11 mm	11 mm	11 mm	11 mm
D Altura eje pedalier	340 mm	340 mm	340 mm	340 mm	340 mm
E Longitud vainas	451 mm	451 mm	451 mm	456 mm	456 mm
F Ángulo tubo sillín real	73,15°	73,15°	73,15°	73,15°	73,15°
G Ángulo tubo sillín efectivo	76,65°	76,65°	76,65°	76,65°	76,65°
H Ángulo dirección	63.15°	63.15°	63.15°	63.15°	63.15°
I Offset de la horquilla	44 mm	44 mm	44 mm	44 mm	44 mm
J Distancia entre ejes	1242 mm	1262 mm	1287 mm	1316 mm	1340 mm
K Longitud pipa	110 mm	110 mm	120 mm	130 mm	140 mm
L Reach	436 mm	456 mm	476 mm	496 mm	516 mm
M Stack	633 mm	634 mm	643 mm	652 mm	661 mm

* La longitud de las vainas aumenta 7 mm al montar una rueda trasera de 29".



2. ESPECIFICACIONES TÉCNICAS DEL CUADRO

TALLAS DE CUADRO	S / M / ML / L / XL
TAMAÑO RUEDA DELANTERA	29"
BUJE DELANTERO	110mm x 20mm (BOOST)
TAMAÑO RUEDA TRASERA	27.5" / 29"
BUJE TRASERO	148mm x 12mm (BOOST)
EJE TRASERO	12X148 P1.0 L180
CAPACIDAD TOTAL DE BIDONES / RANGE EXTENDER	Tubo diagonal para portabidón, tubo superior para accesorios.
MOTOR	Avinox
EJE PEDALIER	Avinox
BATERÍA	800Wh
COMPATIBILIDAD CON RANGE EXTENDER	-
RECORRIDO TRASERO	165mm
AMORTIGUADOR TRASERO	205 x 65mm TRUNNION, 30 x 8mm
RECORRIDO DE HORQUILLA	170mm
DIÁMETRO DE TIJA	31.6mm / 36.9mm
LÍNEA DE CADENA	55mm
DIRECCIÓN	ZS56 / ZS56, 1-1/8", 1.5"
TAMAÑO MÁXIMO DE PLATO	36T
FRENO TRASERO	POST MOUNT, DIRECT 220mm max
TAMAÑO MÁXIMO DE RUEDA	29" x 2.6" (66-622)

3. LONGITUD DE INSERCIÓN DE TIJA

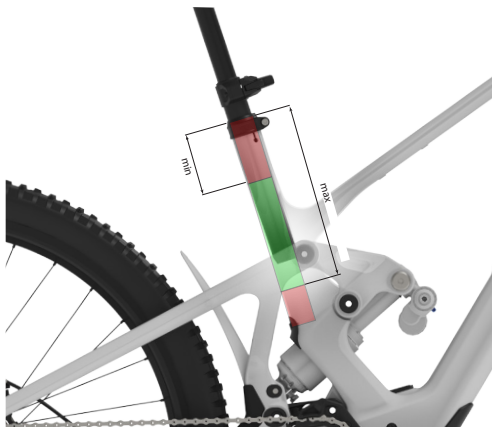

TALLA CUADRO	MIN. (mm)	MAX. (mm)
XL	100	300
L	100	270
ML	100	244
M	100	220
S	100	190



4. COMPONENTES TRANSMISIÓN

4.1. GUIACADENA

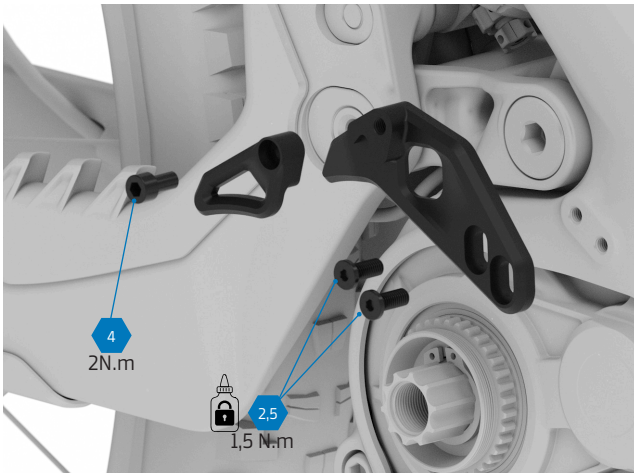

4.2. PLATO

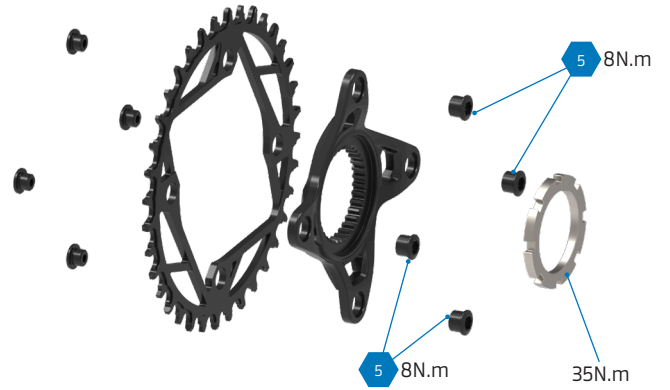

5. TAPA DEL MOTOR

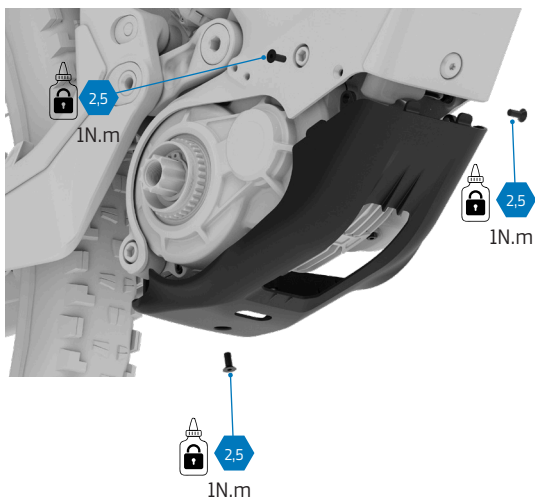



6. MOTOR

6.1. FIJACIÓN DEL MOTOR AL CUADRO

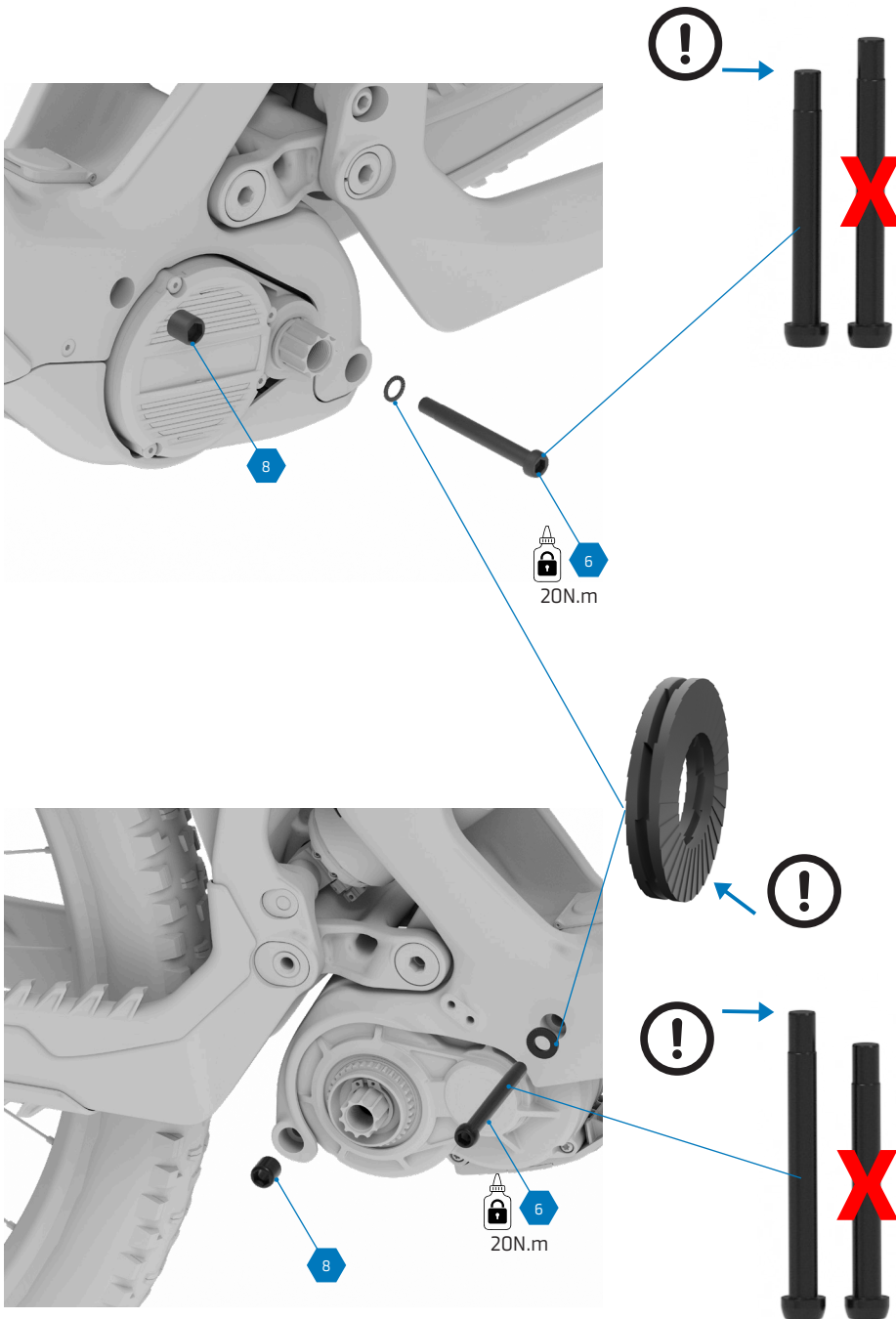

6. MOTOR

6.2. ESPACIADORES ENTRE EL CUADRO Y EL MOTOR

Este paso es necesario únicamente cuando se reemplaza el motor o el cuadro por uno nuevo. Los motores y cuadros que se ensamblan en Mondraker ya vienen con los espaciadores correctos.

Se requiere una herramienta especial de AVINOX para realizar la tarea.

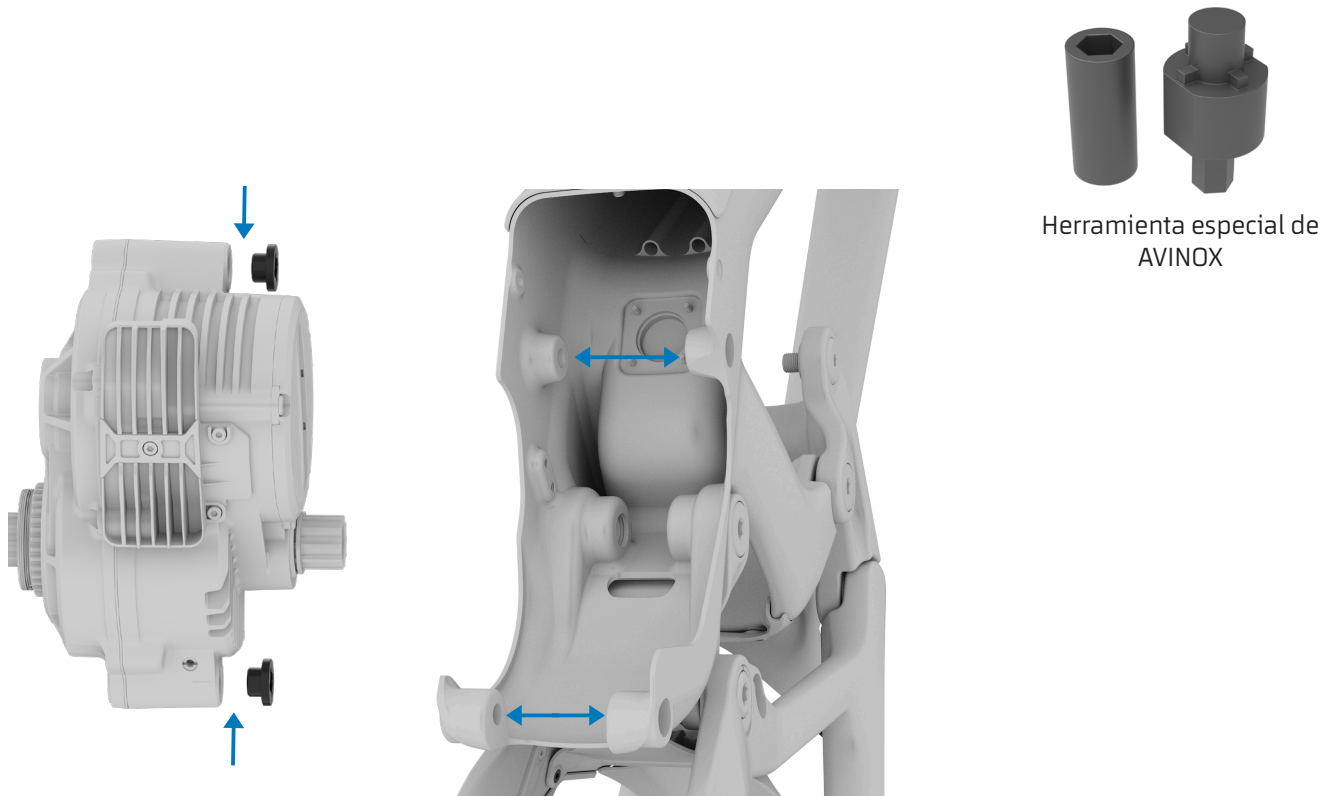

En caso de sustitución del cuadro o del motor, es necesario medir con un calibre la distancia entre las superficies de apoyo de carbono en el alojamiento del motor. En función de esta cota, se deberán instalar los espaciadores o arandelas correspondientes entre el motor y el tornillo, de acuerdo con los valores indicados en la tabla. Es imprescindible verificar las medidas tanto en el anclaje delantero como en el trasero, ya que pueden diferir y, en consecuencia, requerir un número distinto de espaciadores. El apriete final de los tornillos debe realizarse utilizando la herramienta especial de AVINOX, aplicando un par de apriete de **5 Nm**.

A = X - 56.7mm (Punto de anclaje delantero) A = Y - 47.1mm (Punto de anclaje trasero)

Holgura entre el cuadro y el motor	Número de arandelas del punto de montaje
$A < 0.25\text{mm}$	0
$0.25\text{mm} \leq A < 0.50\text{mm}$	0
$0.50\text{mm} \leq A < 0.75\text{mm}$	2
$0.75\text{mm} \leq A < 1.00\text{mm}$	3
$A = 1.00\text{mm}$	4
$A > 1.00\text{mm}$	La tolerancia del cuadro es anormal: la unidad motriz no se puede instalar.



7. PUERTO DE CARGA

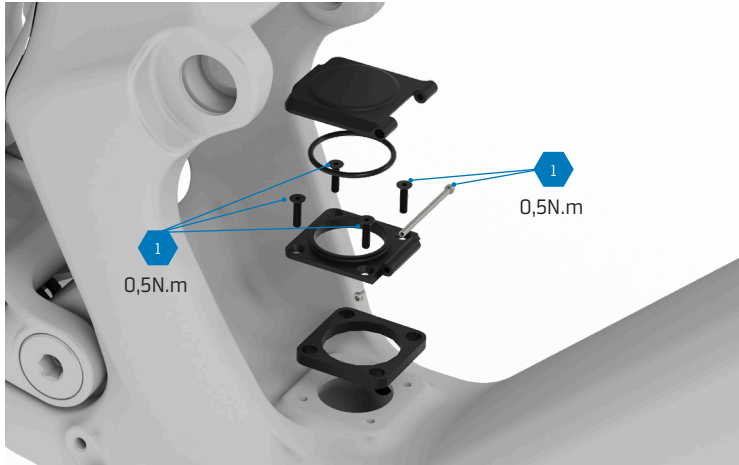

8. GUIADO INTERNO DE CABLES

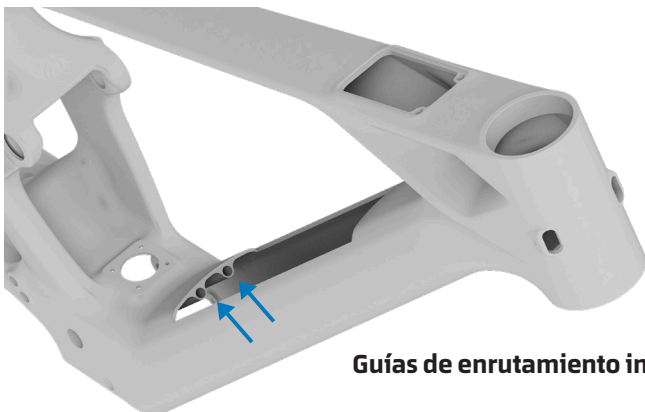
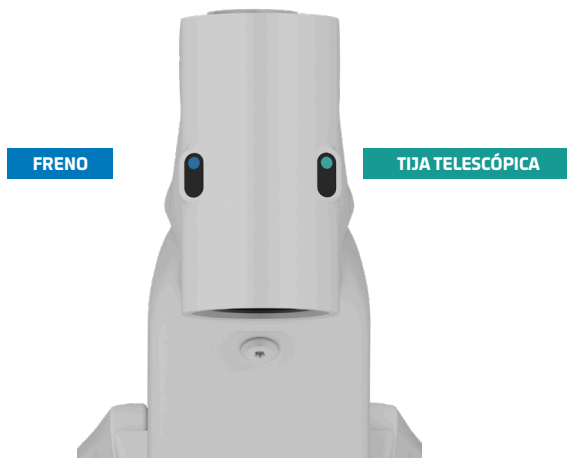

Guías de enrutamiento interno



8. GUIADO INTERNO DE CABLES

8.1 ENTRADAS DE CABLES

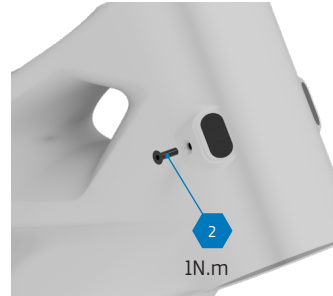
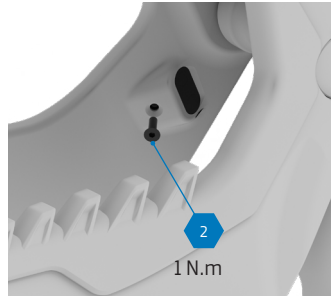
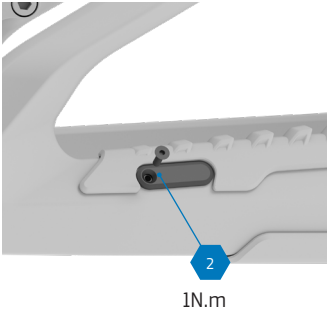

8.2 ENTRADA SENSOR DE VELOCIDAD

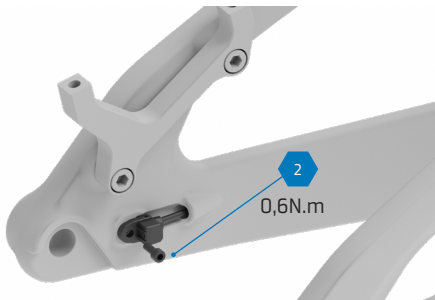

9. TORNILLOS DE LA BATERÍA

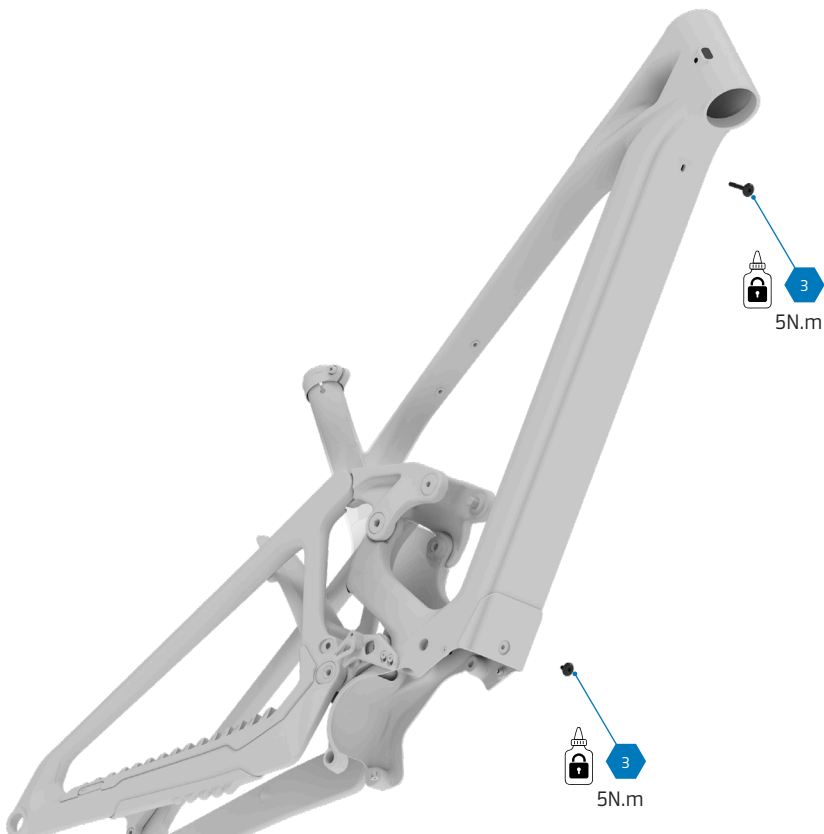



10. DISPLAY



11. MANDO INALÁMBRICO

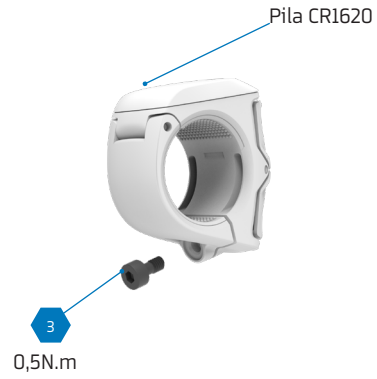

12. GUARDABARROS

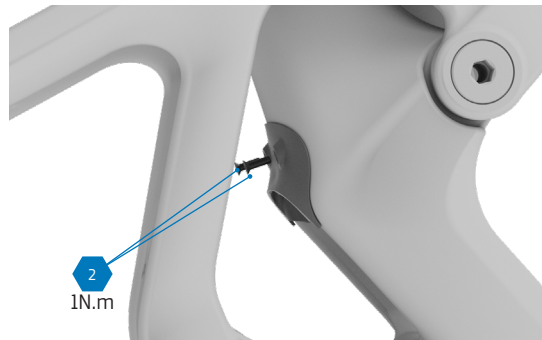
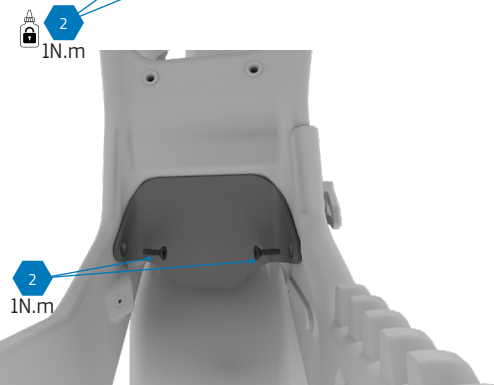
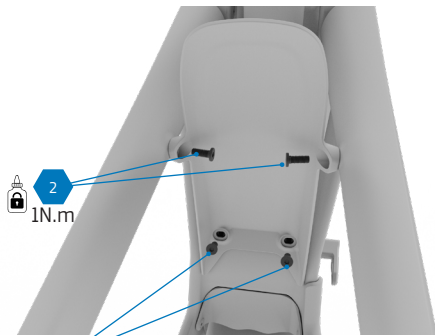

15. CIERRE DE SILLÍN



Se recomienda usar sobre la tija gruesa de fricción para carbono

16. GUÍA DE INSTALACIÓN DE LA BIELETA SUPERIOR



Utilice Loctite 243 para la rosca.
Consejo para Pro: en vez de poner el fijador de roscas en el tornillo, puedes ponerlo en la rosca hembra del cuadro de la bicicleta. Así evitas contaminar con fijador el resto de componentes al insertar el tornillo.

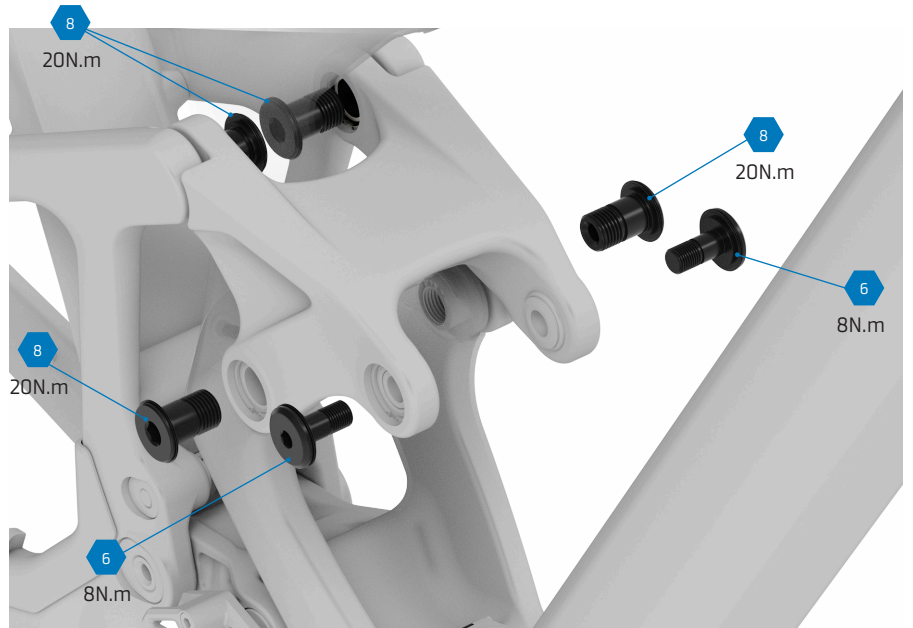
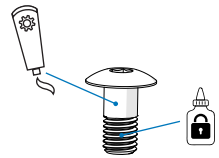

Para los tornillos principales aplica grasa al eje y Loctite 243 a las roscas.

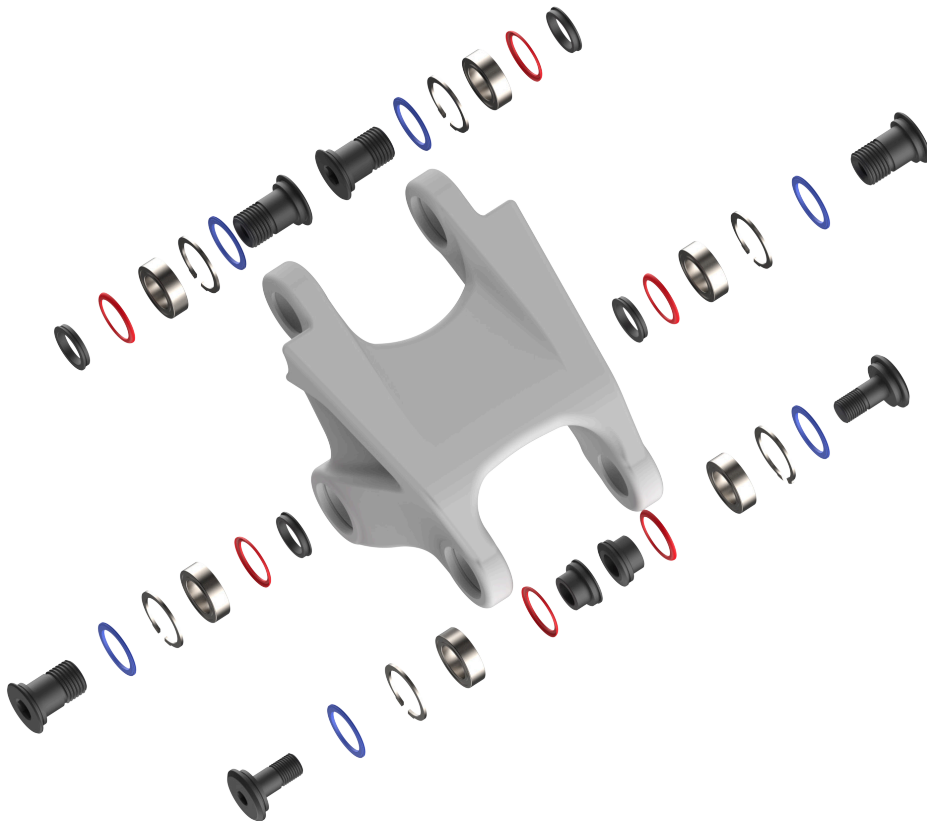

Preste especial atención a la posición de los sellos de goma



Aplique grasa a las zonas de fricción pero evitando contaminar las zonas de rosca

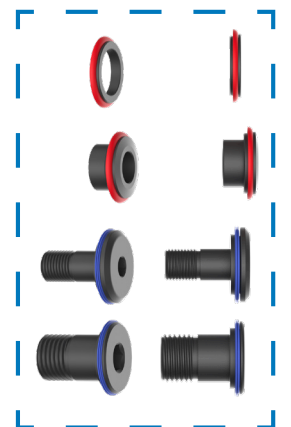



17. GUÍA DE INSTALACIÓN DE LA BIELETA INFERIOR

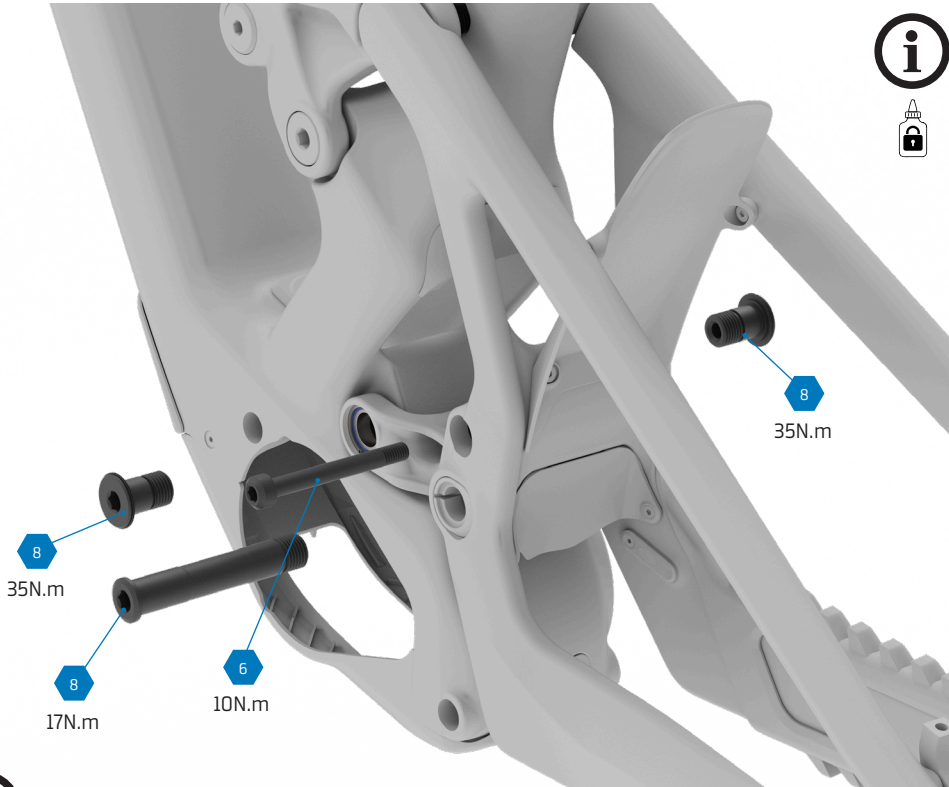

Utilice Loctite 243 para la rosca.
Consejo para Pro: en vez de poner el fijador de roscas en el tornillo, puedes ponerlo en la rosca hembra del cuadro de la bicicleta. Así evitas contaminar con fijador el resto de componentes al insertar el tornillo.

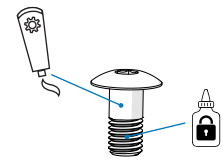

Para los tornillos principales aplica grasa al eje y Loctite 243 a las roscas.

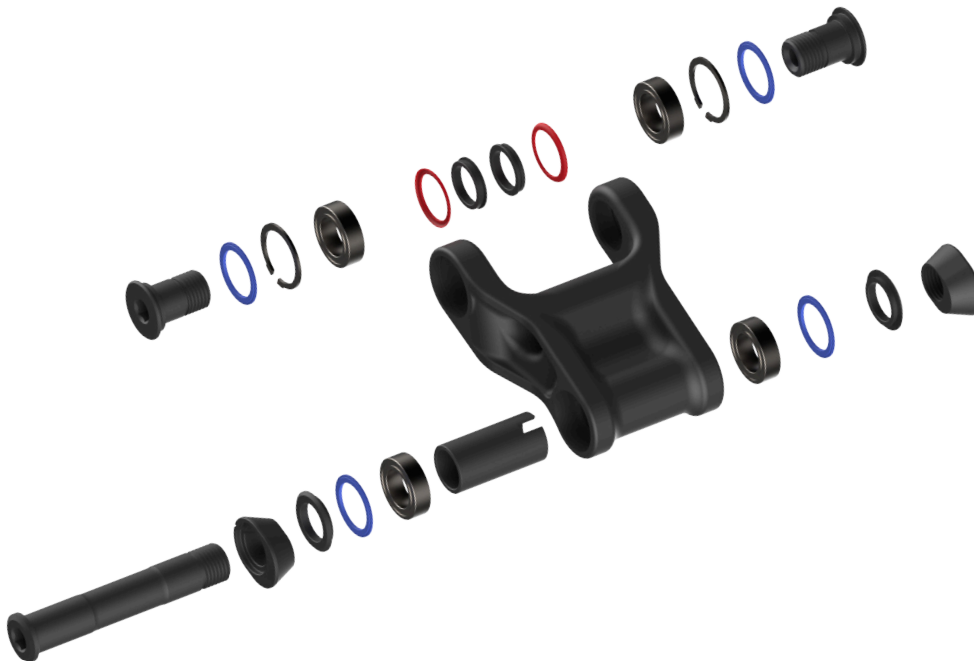

Preste especial atención a la posición de los sellos de goma



Aplique grasa a las zonas de fricción pero evitando contaminar las zonas de rosca

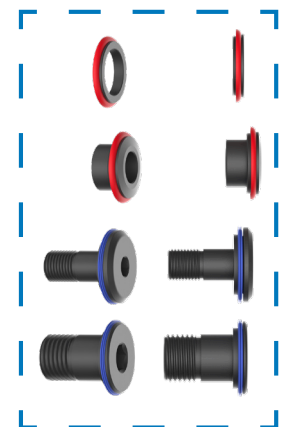



18. FLIP CHIP

18.1 FLIP CHIP PARA CAMBIO DE TAMAÑO DE RUEDA 27.5"-29"

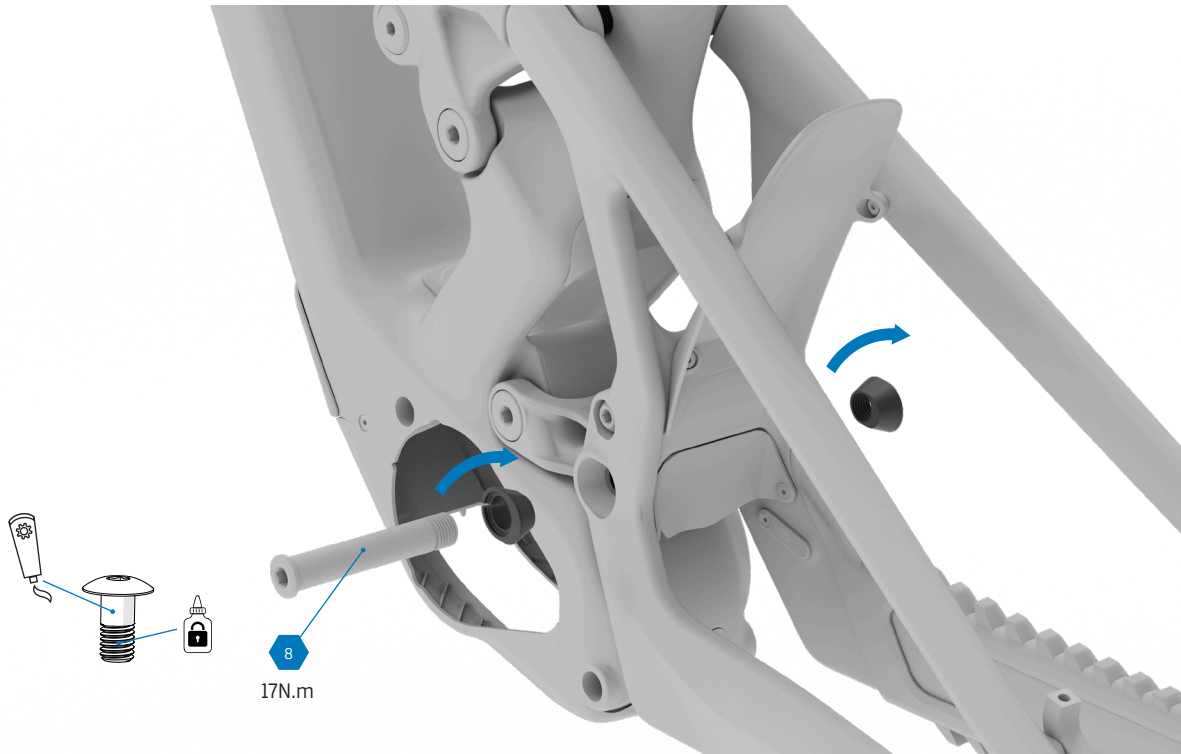

- ❗ Para los tornillos principales aplica grasa al eje y Loctite 243 a las roscas.
- ❗ Aplique grasa a las zonas de fricción pero evitando contaminar las zonas de rosca
- ❗ Cuando pases de rueda de 27,5" a 29" asegúrate de añadir 2 eslabones extra a la longitud de la cadena. Con 27,5" tiene 120 eslabones. Con 29" 122 eslabones. También debes conectar la aplicación Avinox Ride app y actualizar la configuración del wheel set-up.

18.2 FLIP CHIP PARA CAMBIO DE CINEMÁTICA STD - LOW

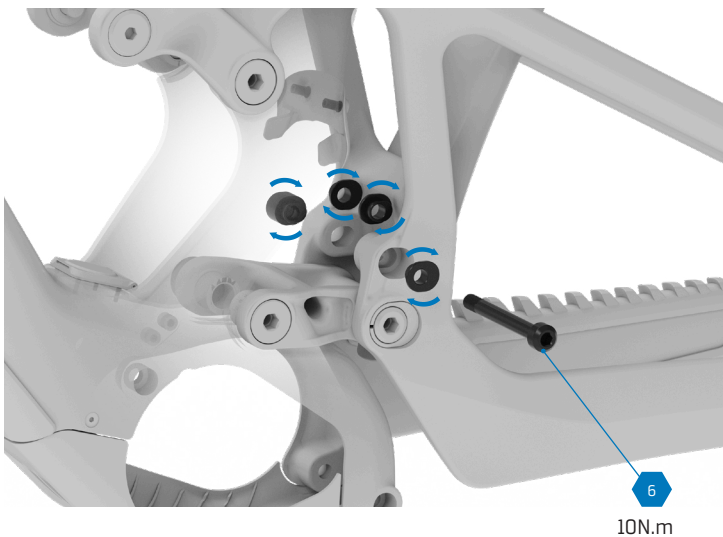

El flip chip para el cambio de cinemática se compone de 4 piezas: 2 externas y 2 internas.



20. SPARE PARTS
ZENDIT

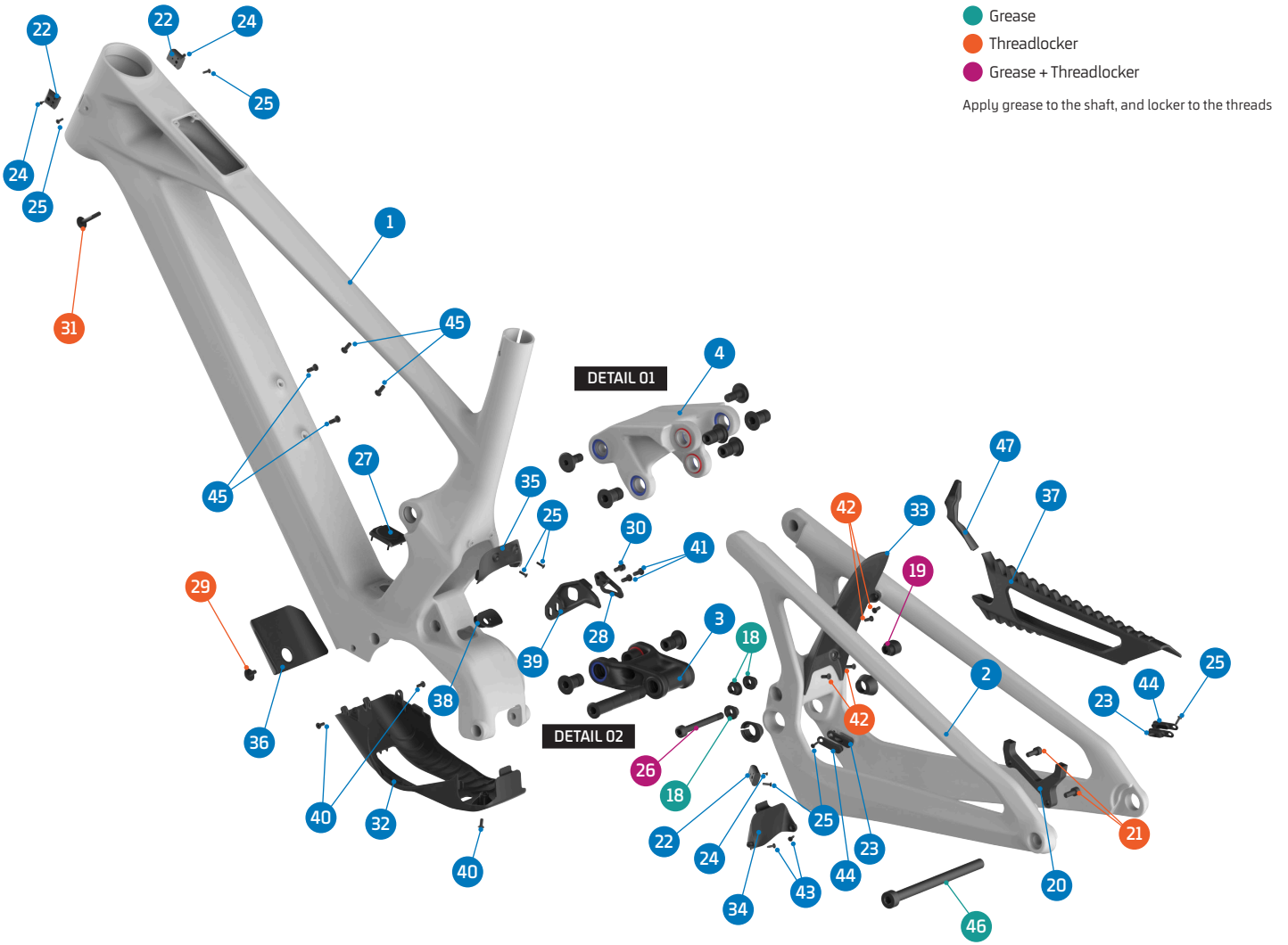

ITEM No.	DESCRIPTION	QTY.	PART NUMBER	TORQUE
1	FRAME	1		
2	REAR TRIANGLE	1		
3	LOWER LINK	1	099.26038	
4	UPPER LINK	1	Refer to B2B web for color options	
5	BEARING, 24x15x7 (3802-2RS)	10	SET 1 / 099.00113	
6	PIVOT WASHER	6	SET 3 & 4	
7	PIVOT SEAL, INTERNAL	8	SET 2, 3, 4 & 8	
8	PIVOT SEAL, EXTERNAL	10	SET 2, 3, 4 & 8	
9	PIVOT AXLE, M15	6	SET 3 & 4	35Nm / 20Nm
10	C-RING	8	SET 2, 3 & 4	
11	SPACER, 38L	1	SET 4	
12	SPACER, LOWER	2	SET 4	
13	PIVOT CHIP, LEFT	1	SET 4 & 099.26049	
14	PIVOT CHIP, RIGHT	1	SET 4 & 099.26050	
15	PIVOT AXLE, 81L	1	SET 4	17Nm
16	SPACER, 10x17x6	2	SET 2	
17	SHOCK BOLT	2	SET 2	8Nm
18	SHOCK FLIP CHIP LEFT	3	099.26044	
19	SHOCK FLIP CHIP RIGHT	1	099.26045	
20	DISC MOUNT	1	SET 6	
21	SCREW BOLT, M6x15	2	SET 6	12Nm
22	CABLE GUIDE	3	SET 7	
23	CABLE GUIDE	2	099.26046	
24	SCREW BOLT, M2,5x5	3	SET 7	1Nm

ITEM No.	DESCRIPTION	QTY.	PART NUMBER	TORQUE
25	SCREW BOLT, M3x10	7	SET 7 & 099.20068	1Nm
26	SHOCK BOLT, 70L	1	SET 2 & 099.26051	10Nm
27	CHARGE PORT COVER	1	099.26052	
28	CHAIN GUIDE OUTER	1	SET 5	
29	SCREW BOLT, M5x10	1	SET 9	5Nm
30	SCREW BOLT, M5x8	1	SET 9	2Nm
31	SCREW BOLT, M5x30	1	SET 9	5Nm
32	MOTOR COVER	1	099.26054	
33	TYRE FENDER	1	099.26055	
34	YOKE FENDER	1	099.26056	
35	FRONT FENDER	1	099.26057	
36	DOWN TUBE PROTECTOR	1	099.20058	
37	CHAINSTAY PROTECTOR	1	099.26059	
38	RUBBER CABLE PROTECTOR	1	099.26060	
39	CHAIN GUIDE BASE PLATE	1	SET 5	
40	SCREW BOLT, M4x10	3	099.26061	2Nm
41	SCREW BOLT, M5x12	2	SET 5	1,5Nm
42	SCREW BOLT, M4x10	4	099.20078	1Nm
43	SCREW BOLT, M3x10	2	099.26063	1Nm
44	CABLE GUIDE, COVER	2	099.26047	
45	SCREW BOLT, M5x8	4		1Nm
46	REAR AXLE	1	112.90027	
47	CHAINSTAY YOKE PROTECTOR	1	099.26109	



DETAIL 01

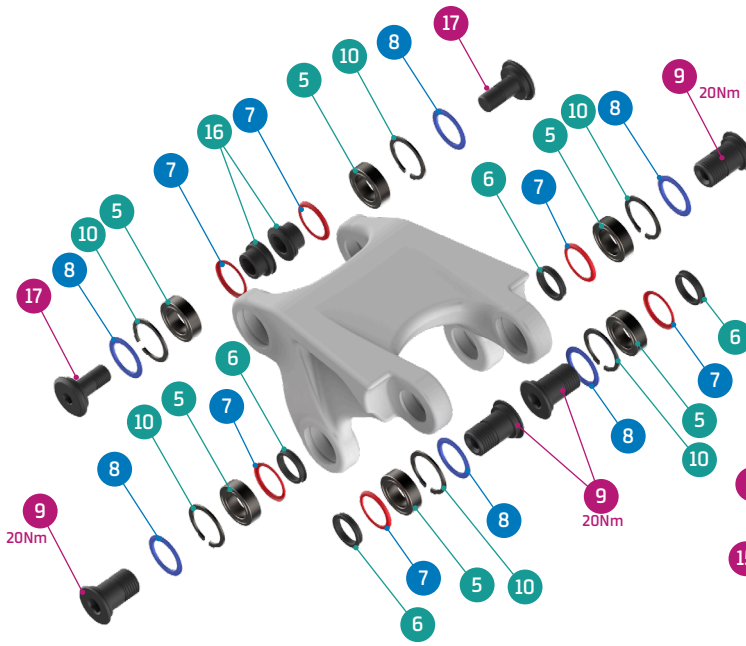

DETAIL 02

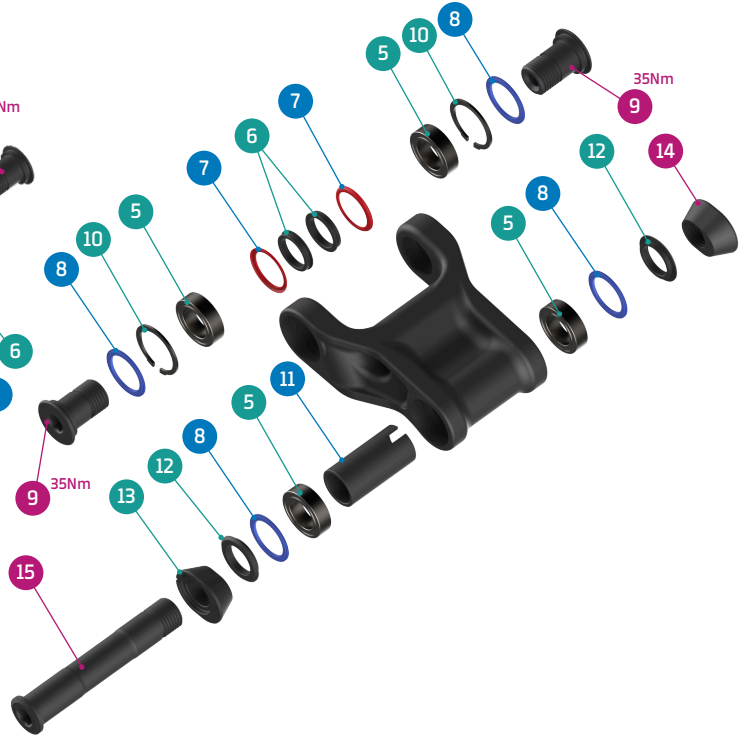

SET 6	SET 7	SET 8	SET 9
-------	-------	-------	-------

DISC ADAPTOR KIT



CABLE GUIDE KIT



SEALS KIT

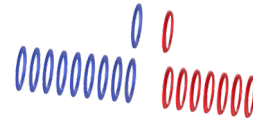

BATTERY BOLTS KIT



SET 1	SET 2	SET 3	SET 4	SET 5
-------	-------	-------	-------	-------

ZERO BEARING KIT 25



SHOCK HARDWARE KIT 23

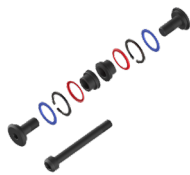

UPPER LINK KIT 34

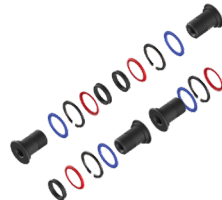

LOWER LINK KIT 38

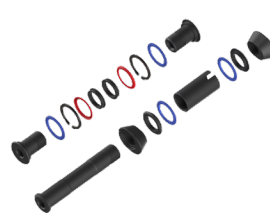

CHAIN GUIDE PLATE + BOLTS



PART NUMBER	DESCRIPTION	COMPONENTS
099.22100	SET 1: ZERO BEARING KIT 25	BEARING 3802-2RS, 24x15x7 (x10)
099.26201	SET 2: SHOCK HARDWARE KIT 23	PIVOT SEAL INTERNAL (x2) / PIVOT SEAL EXTERNAL (x2) / C-RING (x2) / SPACER, 10x17x6 (x2) / SHOCK BOLT (x2) / SHOCK BOLT, 70 (x1)
099.26300	SET 3: UPPER LINK KIT 34	PIVOT WASHER (x4) / PIVOT SEAL INTERNAL (x4) / PIVOT SEAL EXTERNAL (x4) / PIVOT AXLE, M15 (x4) / C-RING (x4)
099.26400	SET 4: LOWER LINK KIT 38	PIVOT WASHER (x2) / PIVOT SEAL INTERNAL (x2) / PIVOT SEAL EXTERNAL (x4) / PIVOT AXLE, M15 (x2) / C-RING (x2) / SCPACER, 38 (x1) / SCPACER LOWER (x1) / PIVOT CHIP LEFT (x1) / PIVOT CHIP RIGHT (x1) / PIVOT AXLE, 81 (x1)
099.26064	SET 5: CHAIN GUIDE PLATE + BOLTS	CHAIN GUIDE BASE (x1) / CHAIN GUIDE OUTER PLATE (x1) / SCREW BOLT, M5X12 (x2) / SCREW BOLT, M5x10 (x1)
099.25018	SET 6: DISC ADAPTOR KIT	DISC ADAPTOR (x1) / SCREW BOLT (x2)
099.26048	SET 7: CABLE GUIDE KIT	CABLE GUIDE (x1) / SCREW BOTL M2.5X5L (x1) / SCREW BOLT M3X10L (x1)
099.26062	SET 8: SEALS KIT	PIVOT SEAL INTERNAL (x8) / PIVOT SEAL EXTERNAL (x10)
099.26053	SET 9: BATTERY BOLTS KIT	SCREW BOLT, M5x10 (x1) / SCREW BOLT, M5x30 (x1)



21. FAQs

¿MANTENDRÉ EL MISMO PASO DE RUEDA TRASERO Y LA MISMA COMPATIBILIDAD DE DISCO AL MONTAR UNA RUEDA TRASERA DE 29"? ¿DEBO CAMBIAR ALGÚN AJUSTE EN LA CONFIGURACIÓN DE LA BICICLETA AL HACERLO?

Al configurar la bicicleta para una rueda trasera de 29", solo es necesario cambiar la posición del flip-chip en el link inferior. La longitud de las chainstays (vainas) aumentará 7 mm en comparación con la configuración estándar mullet, pero el paso de rueda y la posición de la pinza de freno no varían. Nuestra bicicleta viene de serie con configuración mullet. Antes de salir a rodar con una rueda trasera de 29", debes conectar la aplicación Avinox Ride app y actualizar la configuración del wheel set-up.

PREFIERO RODAR SIEMPRE CON UNA CONFIGURACIÓN TOTAL DE 29" (FULL 29ER), ¿POR QUÉ LA ZENDIT SOLO SE OFRECE DE SERIE COMO OPCIÓN MULLET?

La configuración de ruedas Mullet (29" delante / 27.5" detrás) permite una sensación más ágil y juguetona, con un manejo más preciso independientemente de la habilidad del ciclista o el tamaño de la bicicleta. Si prefieres una rueda trasera de 29", el ajuste del flip chip de la Zendit te permite cambiar fácilmente tu configuración para obtener el tacto de conducción que desees sin alterar la geometría ni la cinemática de la suspensión, aumentando únicamente la longitud de las vainas en 7 mm. Debido a esto, asegúrate de añadir 2 eslabones extra a la longitud de la cadena de serie (de 120 eslabones a 122 en total). Todos los modelos y tallas de Zendit vienen equipados de serie con transmisión SRAM T-Type.

¿CUÁNTO PESA EL NUEVO CUADRO ZENDIT?

El nuevo cuadro Stealth Air Carbon en los modelos Zendit RR, RR S y XR es el mismo y pesa exactamente 3.000 gramos (con tornillería incluida) en un cuadro pintado de talla ML (sin el amortiguador trasero).

¿QUÉ AMORTIGUADORES SON COMPATIBLES CON LA NUEVA ZENDIT?

Además de los amortiguadores Fox Float X y Fox Float X2 que montamos en los diferentes modelos Zendit, la bicicleta también es compatible con la serie Fox DHX de muelle, Öhlins TTX de aire o TTX22 m.2 de muelle, y RockShox de muelle o de aire (excepto los modelos Vivid Air y Vivid Coil, que no son compatibles con los cuadros de talla S y M). La Zendit cuenta con amortiguadores de medida métrica de 205 x 65 mm con anclaje superior Trunnion y tornillería estándar inferior de 30x8 mm. Comprueba antes de instalar cualquier otro amortiguador trasero más grande porque podría no caber, ya que el depósito externo (piggyback) podría chocar contra el tubo principal en compresión total.

DT SWISS HA LANZADO UNA NUEVA TECNOLOGÍA RATCHET CON SUS BUJES DEG, ¿ESTÁ DISPONIBLE EN LA ZENDIT?

Sí, tanto el modelo Zendit RR S como el XR cuentan con bujes con tecnología DEG DF anti-pedal kickback, con un movimiento de núcleo específico para e-bikes de 0 o 10 grados. Las bicicletas salen de fábrica con el núcleo configurado en la posición de 10 grados de flotación libre de serie.

¿QUÉ ACTUALIZACIONES CINEMÁTICAS OFRECE LA NUEVA ZENDIT?

La Neat fue nuestro primer modelo en incorporar el diseño evolucionado Zero Suspension con su diseño compacto; esta última generación del esquema de la Zendit ha sido actualizada y mejorada siguiendo las últimas evoluciones de rendimiento vistas en otras bicicletas de doble suspensión de Mondraker recientes, como la Crafty y la Level. La generación Zendit 2027 ofrece una suspensión trasera ligeramente más progresiva (tasa de progresión del 25,7%) y un mayor leverage ratio, resultando más suave y sensible al inicio del recorrido. Presenta curvas de anti-squat y anti-rise ligeramente más bajas para lograr una suspensión trasera más capaz y con mejor rendimiento general. La longitud y carrera del amortiguador también son mayores que en el modelo original, situándose ahora en 205x65 mm. El sag recomendado es del 28% (18 mm), con un máximo recomendado del 33% (21,5 mm).



21. FAQs

¿CUÁL ES EL RECORRIDO MÁXIMO DE HORQUILLA EN LOS MODELOS ZENDIT 2027?

La Zendit es compatible con horquillas de hasta 180 mm de recorrido o 600 mm de altura (axle to crown), aunque no recomendamos nada distinto a los 170 mm que montamos de serie para mantener el equilibrio perfecto de geometría y peso en todas las tallas.

¿ES POSIBLE MONTAR UN DISCO DE FRENO TRASERO MÁS GRANDE DE 220 MM EN LA ZENDIT?

Sí, la Zendit es compatible con discos de freno traseros de hasta 220 mm. Es algo que no recomendamos especialmente con los últimos frenos de gran potencia, como los SRAM Maven que vienen de serie, pero sí, es posible instalar discos de hasta 220 mm en la parte trasera de todos los nuevos modelos Zendit.

HAY DOS POSICIONES DE GEOMETRÍA EN LA ZENDIT, ¿CÓMO FUNCIONA?

Al igual que en nuestros modelos Crafty Carbon o Level, la Zendit ofrece 2 posiciones de geometría mediante un flip chip. La bicicleta viene de serie en la posición "Standard"; al invertir el chip pasamos a la posición "Low", donde el eje de pedaliador baja 5 mm y el ángulo del tubo de dirección cambia en -0.35° . Es una operación muy sencilla: afloja el tornillo inferior del amortiguador con una llave Allen de 6 mm y voltea las 4 piezas de aluminio de ambos lados (2 por lado, interna y externa), tal como se muestra en el cuadro. Instala de nuevo el tornillo del amortiguador y habrás terminado. Puedes consultar todas las tablas de geometría completas en la web de Mondraker.

¿CUÁL ES EL ANCHO MÁXIMO DE NEUMÁTICO QUE CABE EN LA ZENDIT?

La Zendit es compatible con neumáticos de hasta 66 mm de ancho, lo que se traduce en cubiertas de 27.5" o 29" x 2.6". Se recomienda medir el neumático antes de instalarlo, ya que el ancho real puede variar respecto al indicado según el fabricante.

¿SERÍA POSIBLE AÑADIR UN EXTENSOR DE BATERÍA (RANGE EXTENDER) EN LA ZENDIT PARA AUMENTAR LA AUTONOMÍA?

No, la Zendit con motor Avinox cuenta únicamente con la batería interna de 800Wh y no hay ningún extensor de autonomía disponible.

¿PUEDO LLEVAR UN BIDÓN DE AGUA?

Sí, es posible. Hay 2 ubicaciones posibles para el portabidón en el cuadro principal: la posición estándar (como en cualquier otra bicicleta) y debajo del tubo superior (top tube).

EL NUEVO GUIADO DE CABLES ES EXTERNO A TRAVÉS DEL TUBO DE DIRECCIÓN, ¿ES POSIBLE PASAR LOS CABLES INTERNAMENTE POR LA DIRECCIÓN?

Sí, puedes hacerlo. La tapa superior de la dirección está preparada para guiar los cables a través de ella y realizar una instalación completamente interna si así lo prefieres.

¿ES POSIBLE DESMONTAR LA BATERÍA INTERNA?

Es posible retirando primero el motor. Esta operación debe ser realizada por un mecánico cualificado en un distribuidor autorizado, aunque en Mondraker no recomendamos desmontar la batería en ningún caso.



21. FAQs

¿CUÁNTO TIEMPO TARDA EN CARGARSE COMPLETAMENTE LA BATERÍA?

Con el cargador rápido (12A - GaN - 508W) que viene de serie en el modelo XR, puedes cargar de 0 a 75% en solo 1h 30 min y de 0 a 100% en 2h 25 min. Los modelos RR S y RR incluyen el cargador estándar de Avinox de 4A - 168W, con el que puedes cargar de 0 a 75% en 4h 28 min y de 0 a 100% en 5h 10 min.

LOS DESVIADORES TRASEROS T-TYPE DE ÚLTIMA GENERACIÓN DE SRAM PUEDEN FUNCIONAR CONECTADOS DIRECTAMENTE A LA BATERÍA PRINCIPAL DE LA BICI MEDIANTE EL CABLE DE ALIMENTACIÓN. ¿ES POSIBLE HACERLO EN LOS ÚLTIMOS MODELOS ZENDIT?

Sí, de hecho, esta función viene de serie en todos los modelos Zendit RR, RR S y XR. Gracias a esta configuración, la función SmoothShift está disponible y aparecerá en tu pantalla Avinox como una opción para activar o desactivar. Cuando el SmoothShift está activado y se detecta un cambio de marcha, el motor girará automáticamente el plato independientemente de las bielas, permitiéndote cambiar a una marcha superior o inferior mientras rodas por inercia (sin pedalear y sin mover las bielas). Para proteger la transmisión, el sistema utiliza una fusión de múltiples sensores para reducir momentáneamente el par del motor durante estos cambios, asegurando que la cadena se mueva suavemente entre los piñones. Esta precisión evita el desgaste excesivo al sincronizar la rotación del motor con la velocidad de la rueda durante el cambio, restaurando instantáneamente todo el par en cuanto se completa el cambio de marcha.

LA ZENDIT MONTA TRANSMISIÓN SRAM T-TYPE, ¿SERÍA POSIBLE UTILIZAR UNA TRANSMISIÓN Y DESVIADOR TRASERO SHIMANO?

Sí, totalmente. Solo ten en cuenta que necesitarías una patilla de cambio UDH adicional para el desviador trasero Shimano.

¿CUÁL ES EL NIVEL MÁXIMO DE ASISTENCIA QUE PUEDO OBTENER DEL MOTOR AVINOX M2S DE LA ZENDIT?

La asistencia máxima es del 800% con 150Nm y 1.300W en modo Boost.

¿ES POSIBLE PERSONALIZAR LOS MODOS DE ASISTENCIA EN LA ZENDIT?

Sí, puedes personalizar los modos de asistencia del sistema Avinox M2S de la misma manera que con otros sistemas de motor. Puedes hacerlo directamente en la pantalla de la bicicleta o a través de la aplicación Avinox Ride app en tu teléfono móvil. Es una operación muy sencilla y podrás ajustar cada parámetro de conducción a tu gusto muy fácilmente. En la web de Avinox o en la app encontrarás toda la información relativa a la personalización del motor y la configuración de los diferentes modos: Auto, Eco, Trail, Turbo y Boost.

¿CUÁNTO TIEMPO PUEDO RODAR CON LA NUEVA ZENDIT?

Esta es siempre una pregunta compleja y, como siempre, depende del nivel de asistencia utilizado, la forma física del ciclista, su peso y las condiciones del terreno. Con la batería de serie de 800Wh, un ciclista medio de 80 kg de peso puede subir unos 2.000 m de desnivel positivo combinando diferentes modos y rodar hasta 4 horas en modos AUTO-ECO. De nuevo, esto dependerá de las condiciones de la ruta y del nivel físico del usuario.

¿QUÉ INFORMACIÓN OFRECE LA PANTALLA DE LA ZENDIT?

Puedes encontrar toda la información del manual de la pantalla y el mando remoto en el siguiente enlace: <https://www.avinox-ebike.com/>



21. FAQs

¿QUÉ TIPO DE MANTENIMIENTO O COMPROBACIONES DE SEGURIDAD REQUIERE EL MOTOR AVINOX M2S?

Absolutamente ninguno. No es necesario lubricar ninguna pieza de la unidad de potencia ni desmontarla... lo único que debes hacer es cuidarla como harías con una bicicleta de montaña tradicional. No obstante, es importante mencionar precauciones aplicables a cualquier MTB: las partes electrónicas y, específicamente, la zona del eje de pedalier donde se ubica el motor, nunca deben limpiarse con máquinas de alta presión. No se recomienda usar chorros de agua a presión directamente sobre el eje de las bielas, ya que los componentes electrónicos podrían sufrir daños graves.

¿QUÉ TALLA DE BICICLETA NECESITO?

Los modelos Zendit se presentan en 5 tallas, con una talla ML situada entre la Mediana y la Grande. En comparación con la opción de 4 tallas que ofrecemos en otros modelos de Mondraker, las nuevas tallas Small y Medium son ligeramente más pequeñas que las anteriores, mientras que las nuevas Large y Extra Large son ligeramente más grandes. Consulta las tablas de geometría para más detalles.

<165 cm	165-170 cm	170-175 cm	175-180 cm	180-185 cm	185-190 cm	190-195 cm	>195 cm
S			M/L				XL
	M				L		



Toda la información e imágenes que contiene este documento se proporcionan, únicamente, a título informativo y no constituyen un contrato legal entre Mondraker y ninguna persona ni entidad. Las especificaciones, geometrías o cualquier otra información técnica aquí publicada están sujetas a cambios sin necesidad de previo aviso.

© © Todas las marcas y modelos son propiedad de Blue Factory Team, S.L.U. y cuentan con la protección de las leyes vigentes y los acuerdos internacionales de aplicación.