



MANUALS & DOCUMENTS

—
SCREE

SCREE

EN	3
MANUALS & DOCUMENTS	
DE	33
ANLEITUNGEN UND DOKUMENTE	
FR	63
MANUELS ET DOCUMENTS	
IT	93
MANUALI E DOCUMENTI	
ES	123
MANUALES Y DOCUMENTOS	

MANUALS & DOCUMENTS





GENERAL AND SAFETY INSTRUCTIONS

This technical guide may use the following 3 icons. Each icon denotes that the following precautions should be taken:

WARNING:

Improper use or failure to follow directions may result in serious injury or death. These tasks are technically difficult and, if not performed properly, could cause damage to your bicycle or void your warranty.

CAUTION:

Improper use or failure to follow directions may result in minor injuries. These tasks are technically difficult and, if not performed properly, could cause damage to your bicycle or void your warranty.

INFORMATION

Essential information to correctly perform this task in order to avoid any damage to the bicycle or void the warranty, without any risk to people.

FURTHER CONSIDERATIONS

- Using non-original spare parts can lead to damage, malfunctions and accidents with potentially serious consequences.
- Some of the steps described in this manual require skills beyond those of the average bicycle user. If you are unable to follow any of these steps, please arrange for your bicycle to be serviced and replaced at an authorized Mondraker service centre. Installing spare parts incorrectly may result in malfunctions, accidents, injuries and void the warranty.

CLEANING AND MAINTENANCE

- Once the parts have been disassembled, components to be reused should be cleaned, greased and thread sealed (if necessary).

SYMBOL LEGEND



Medium grade threadlocker. Loctite 243 or similar.



Quality synthetic assembly grease.



Special carbon friction grease.



1. DIMENSIONS

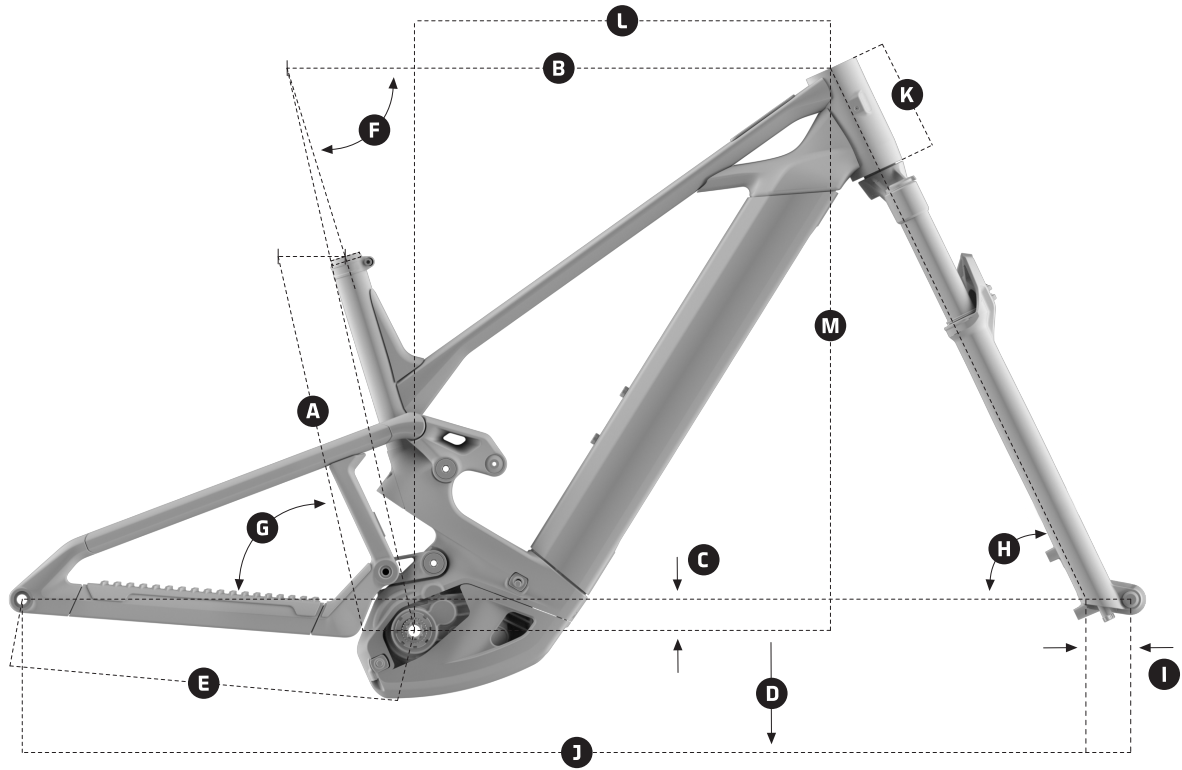

SCREE

FRAME SIZE	S	M	ML	L	XL
A Seat Tube Length	380 mm	410 mm	435 mm	460 mm	490 mm
B Top Tube Length	587,6 mm	607,6 mm	628,8 mm	650,7 mm	672,8 mm
C Bottom Bracket Drop	-35 mm	-35 mm	-35 mm	-35 mm	-35 mm
D Bottom Bracket Height	340 mm	340 mm	340 mm	340 mm	340 mm
E Chainstay Length	456 mm	456 mm	456 mm	456 mm	456 mm
F Seat Tube Angle, Actual	74°	74°	74°	74°	74°
G Seat Tube Angle, Effective	77°	77°	77°	77°	77°
H Headtube Angle	65,5°	65,5°	65,5°	65,5°	65,5°
I Fork Offset	44 mm	44 mm	44 mm	44 mm	44 mm
J Wheelbase	1221,2 mm	1241,2 mm	1263,3 mm	1287,4 mm	1311,5 mm
K Headtube Length	125 mm	125 mm	130 mm	140 mm	150 mm
L Reach	440 mm	460 mm	480 mm	500 mm	520 mm
M Stack	644,6 mm	644,6 mm	649,2 mm	658,3 mm	667,4 mm



2. FRAME TECHNICAL SPECIFICATIONS

FRAME SIZES	S / M / ML / L / XL
FRONT WHEEL SIZE	29"
FRONT AXLE	110mm x 15mm (BOOST)
REAR WHEEL SIZE	29"
REAR AXLE	148mm x 12mm (BOOST)
REAR SHAFT	12X148 P1.0 L180
NUMBER OF BOTTLE CAGES	2 positions, 1 BOTTLE CAGE / RANGE EXTENDER
DRIVE UNIT	BOSCH PERFORMANCE LINE CX
BOTTOM BRACKET	BOSCH
BATTERY	800Wh / 600Wh
RANGE EXTENDER	BOSCH POWERMORE 250Wh
REAR WHEEL TRAVEL	130mm
REAR SHOCK	165 x 45mm TRUNNION, 30 x 8mm
FRONT WHEEL TRAVEL	150mm
SEATPOST DIAMETER	31.6mm / 34.9mm
CHAIN LINE	55mm
HEADSET	ZS56 / ZS56, 1-1/8", 1.5"
MAXIMUM CHAINRING SIZE	34T
REAR BRAKE	POST MOUNT, DIRECT 220mm max
MAXIMUM COMPATIBLE WHEEL SIZE	29" x 2.6" (66-622)

3. SEATPOST INSERTION DEPTH

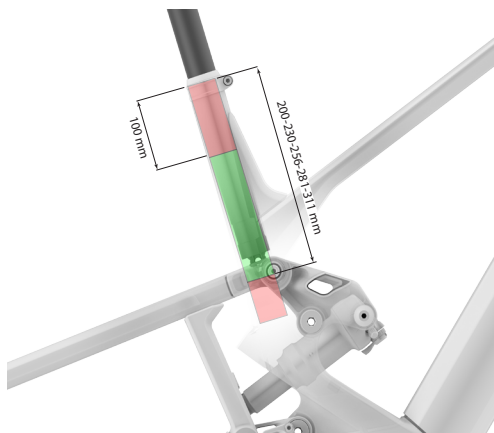

FRAME SIZE	MIN. (mm)	MAX. (mm)
XL	100	311
L	100	281
ML	100	256
M	100	230
S	100	200



4. DRIVE COMPONENTS

4.1. CHAIN GUIDE

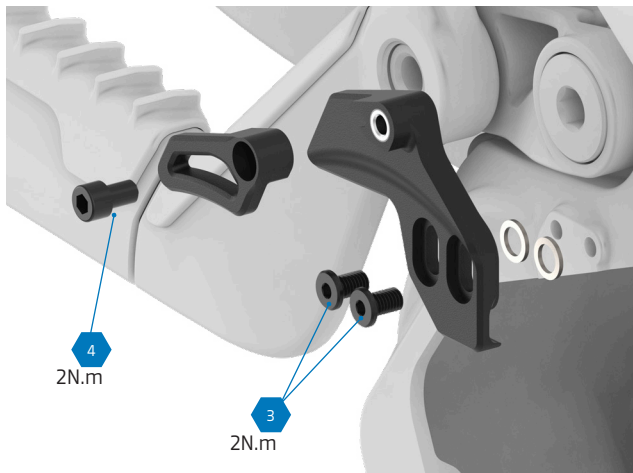

4.2. CHAINRING



Consult the chainring manufacturer's manual to determine if your chainring is o-ring compatible.

5. MOTOR COVER

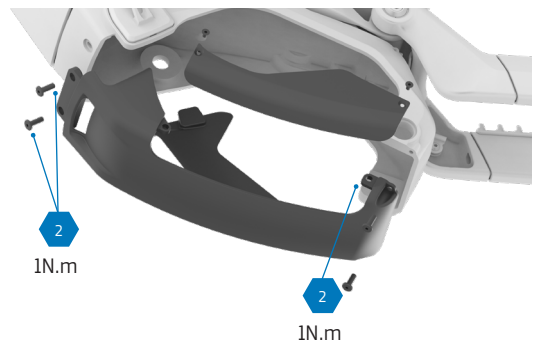
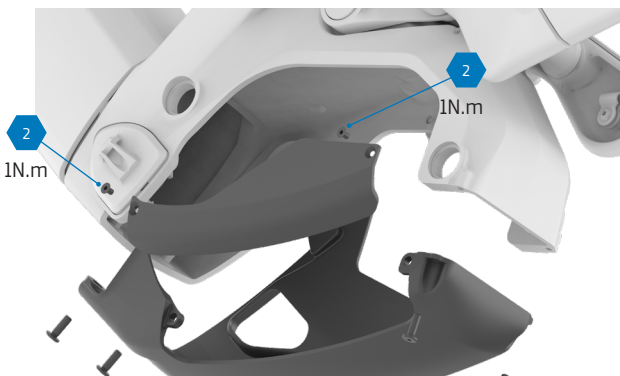



6. MOTOR REMOVAL



Do not use Loctite 243

6.1. MOTOR CONNECTIONS

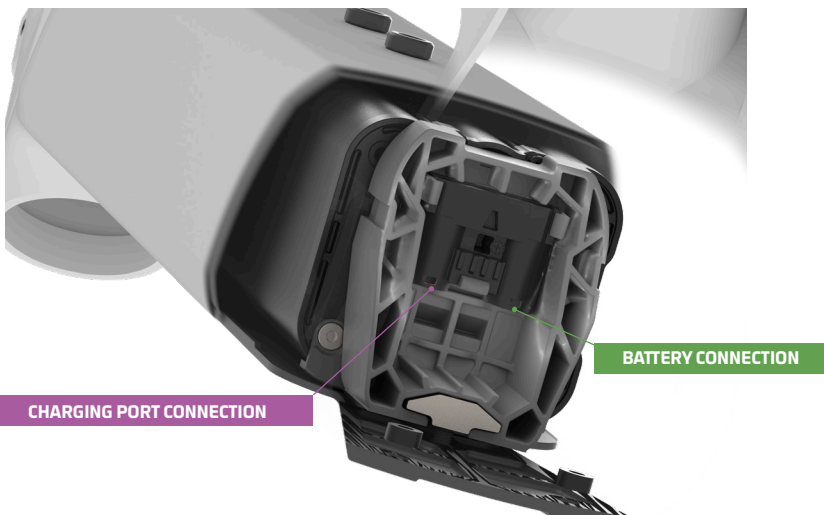
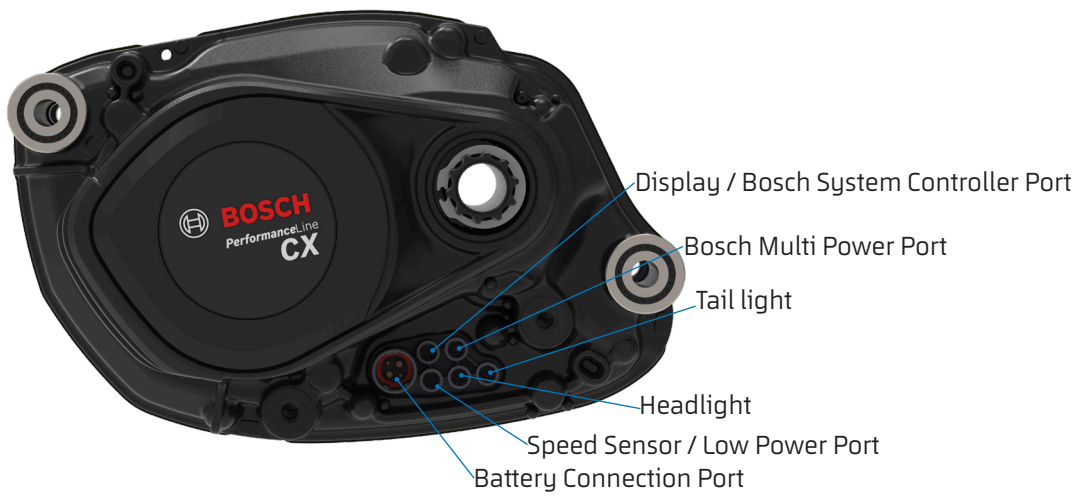



7. CHARGING PORT

7.1 REMOVE CHARGING PORT

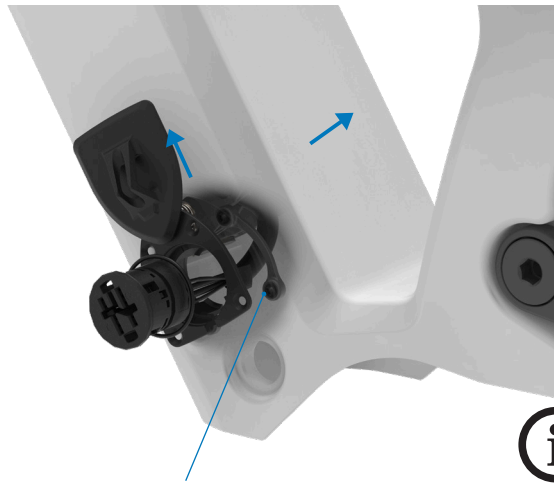
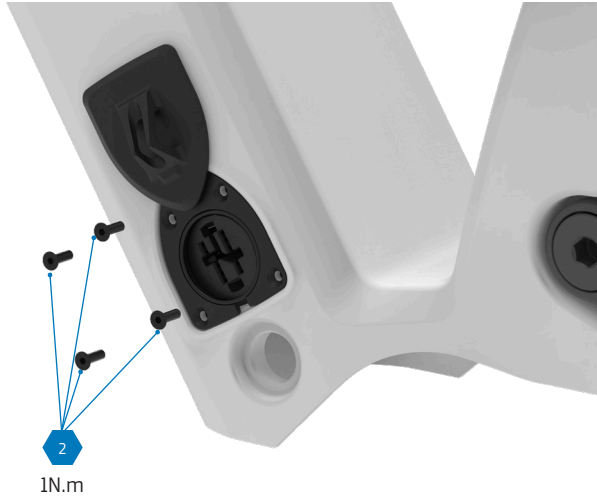



8. BATTERY REMOVAL

STEP 1

Unscrew the first thread section of the bolt. The battery will come out but will remain attached to the frame.

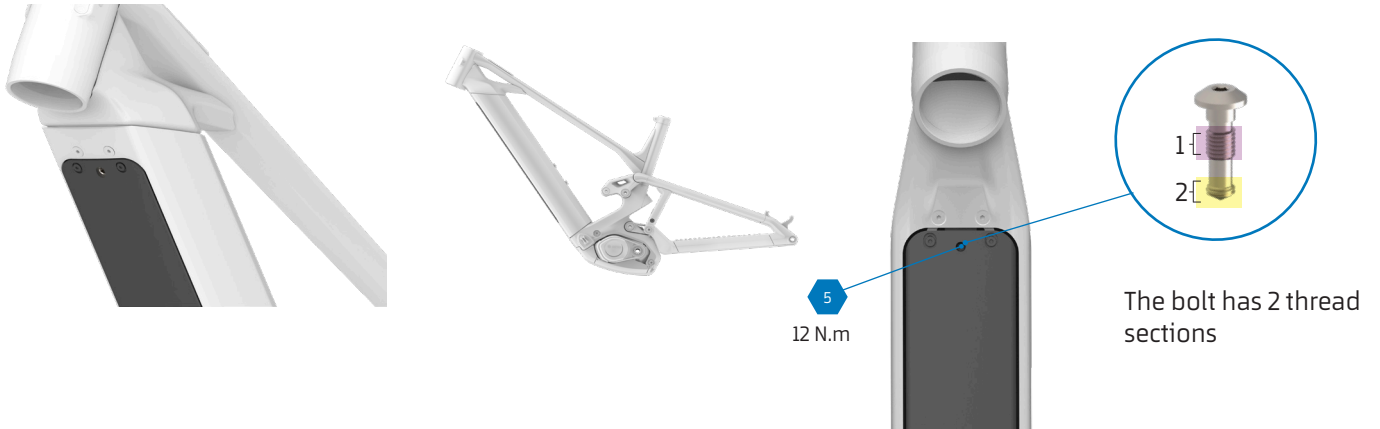

END OF STEP 1

At this stage, hold the battery with your hand and keep unscrewing the second section of the thread.

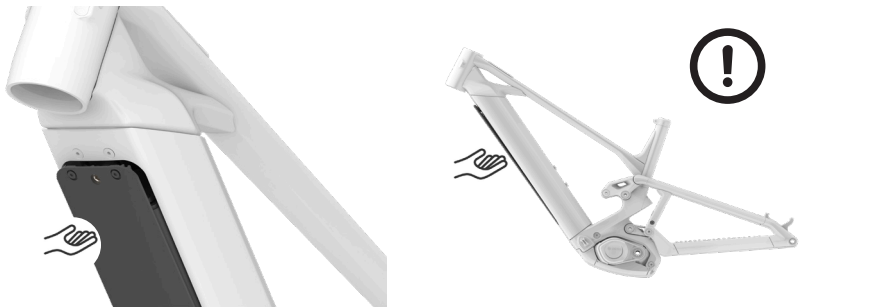

STEP 2

The battery is now free. Be careful, the battery is heavy. If you don't hold the battery firmly, it could hit the ground and permanently be damaged.

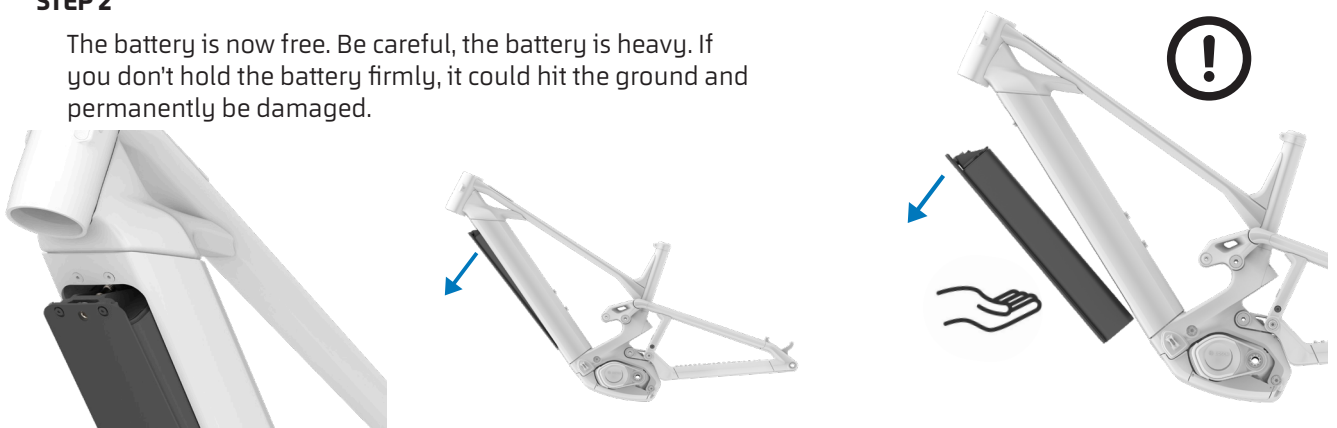



9. INTERNAL CABLE ROUTING

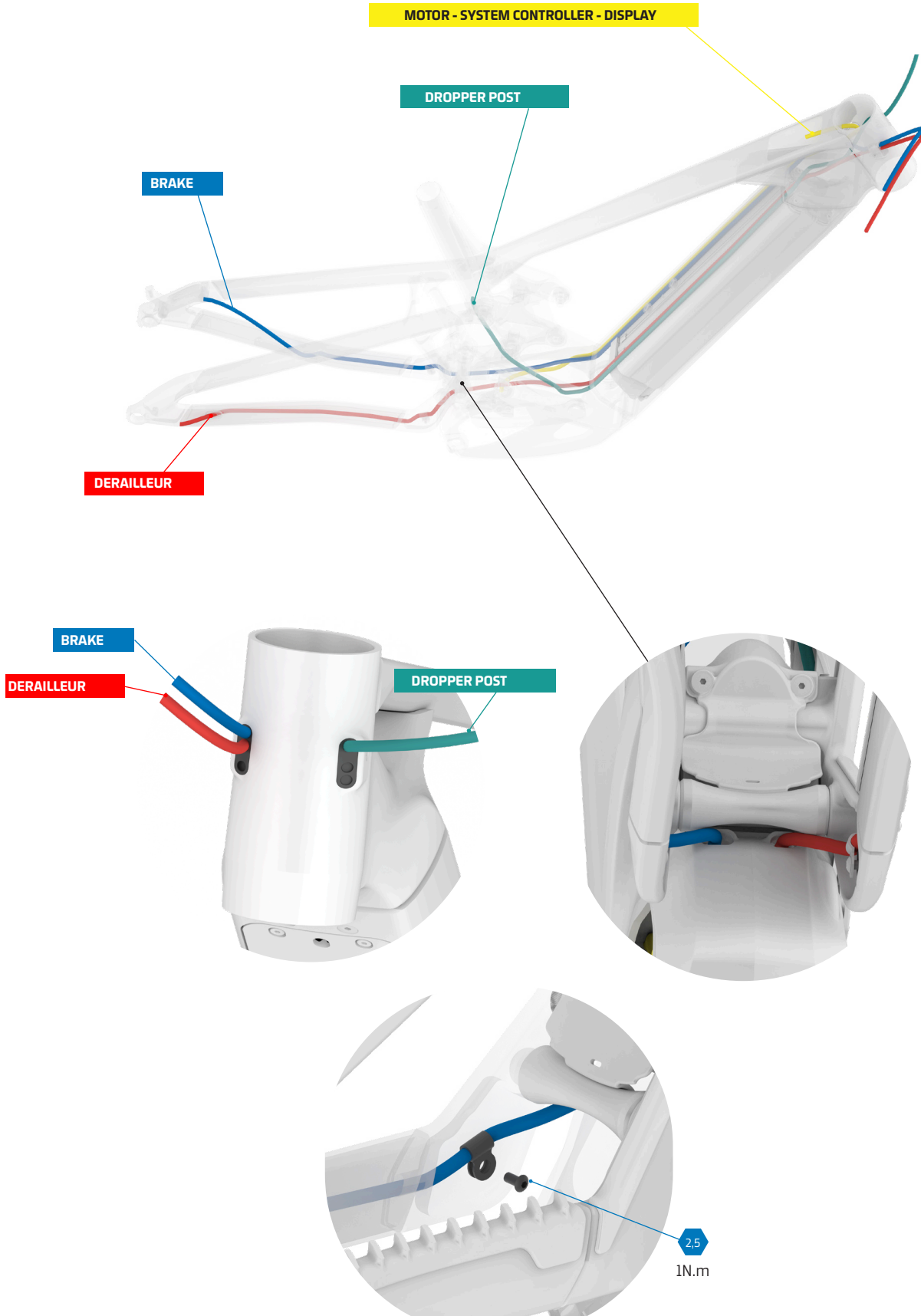



10. BATTERY CLAMPING

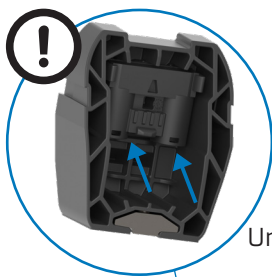
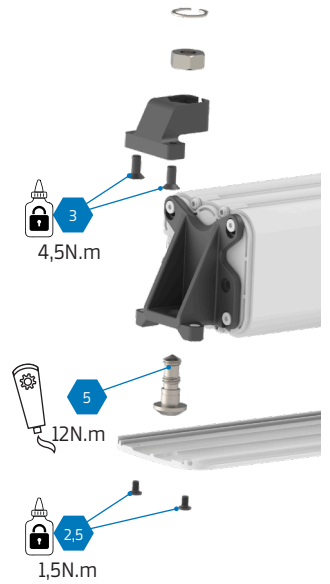
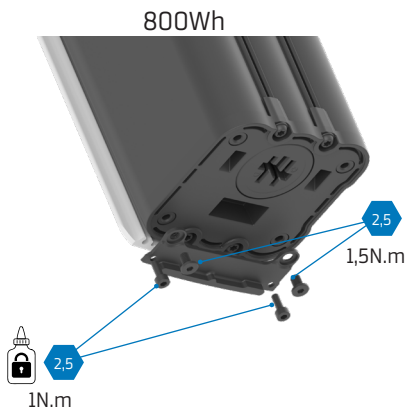
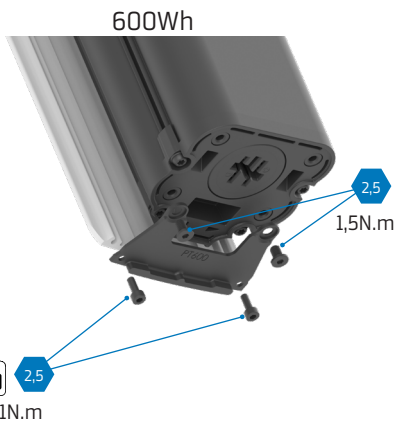
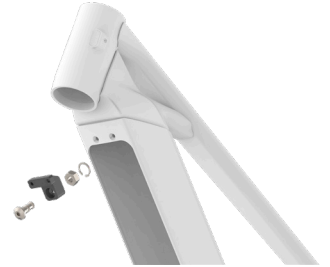
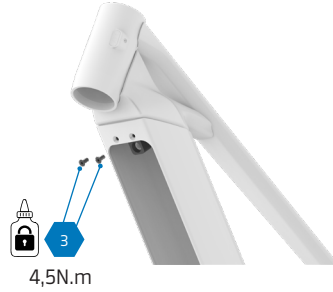



11. BATTERY CONVERSION 600WH / 800WH

11.1 INSTALL THE BATTERY FASTENERS

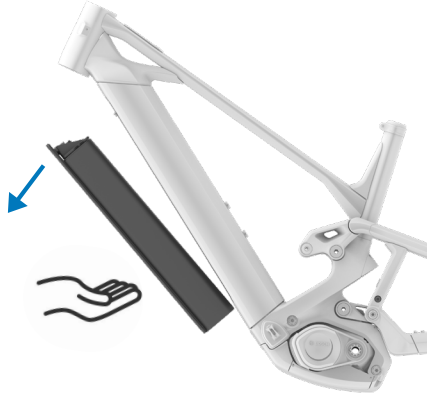

600Wh



800Wh

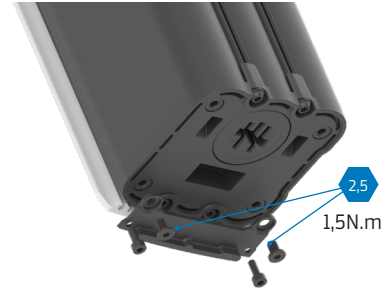

600Wh

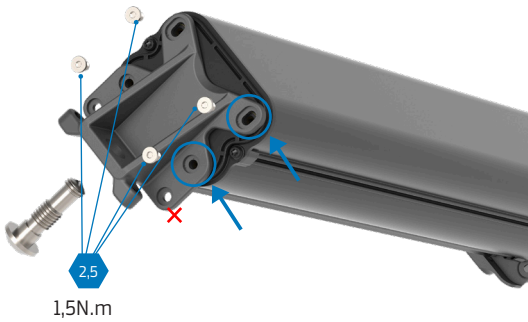

800Wh

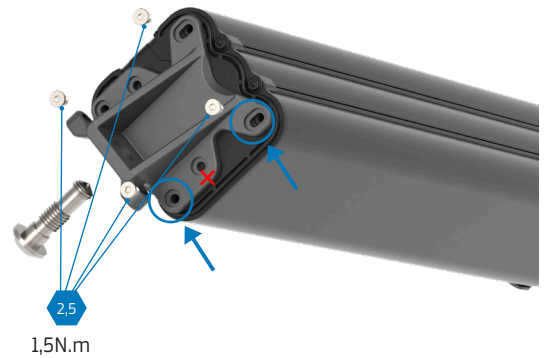



11. BATTERY CONVERSION 600WH / 800WH

11.2. INSTALL THE BATTERY COVER

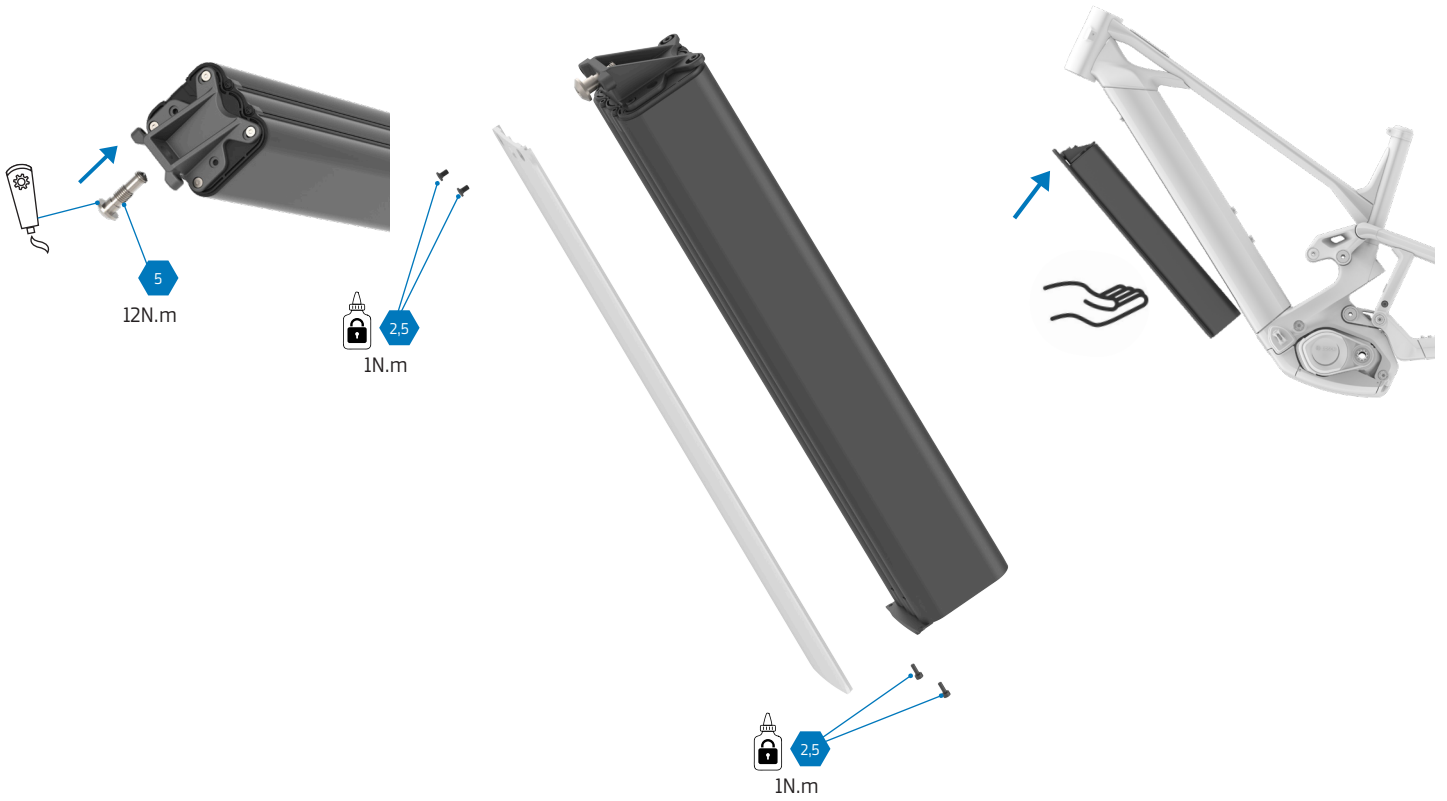

8. 4. REFERENCES



BATTERY HOLDER
FRONT 800Wh/600Wh
Ref. 099.25049



BATTERY HOLDER REAR
800Wh
Ref. 099.26020



BATTERY HOLDER REAR
600Wh
Ref. 099.26021



8. 5. SPARE PARTS NEEDED FOR A SECOND BATTERY

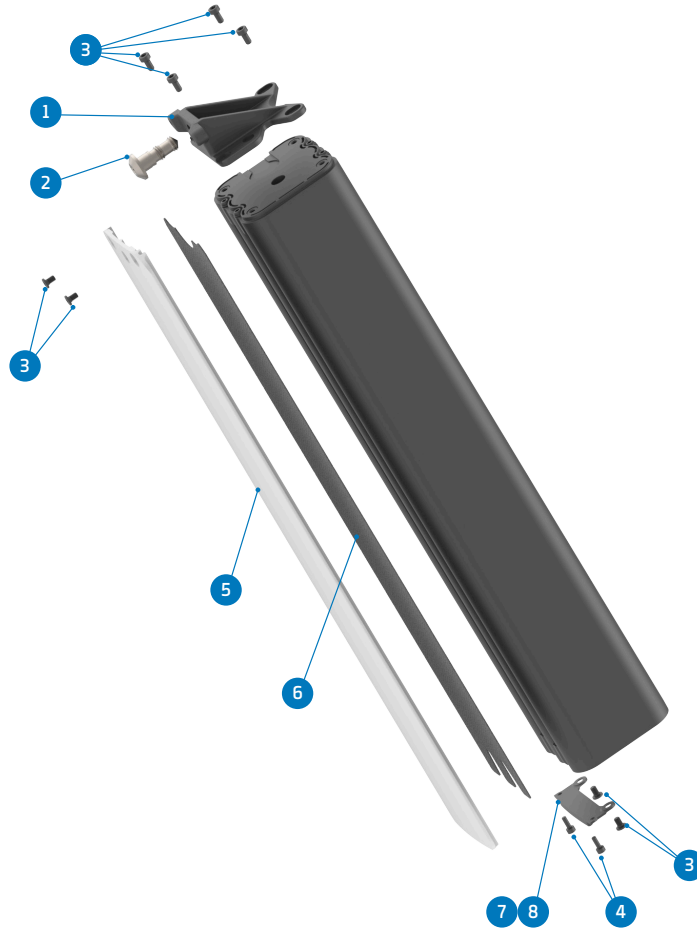

ITEM	DESCRIPTION	QTY.	PART NUMBER
1	BATTERY MOUNT BRACKET FRONT	1	099.25049
2	BATTERY RELEASE SCREW	1	099.25051
3	SCREW BOLT M4X6	8	099.25052
4	SCREW BOLT M4X8	2	099.12116
5	BATTERY COVER	1	Refer to B2B web for color options
6	FOAM FOR BATTERY COVER	1	099.25089
Choose between:			
7	BATTERY HOLDER REAR 800Wh (only for 800Wh battery)	1	099.26020
8	BATTERY HOLDER REAR 600Wh (only for 600Wh battery)	1	099.26021
9	FOAM FOR 600Wh BATTERY (only 600wh battery)	1	099.25097



BATTERY HOLDER REAR
800Wh
Ref. 099.26020

BATTERY HOLDER REAR
600Wh
Ref. 099.26021



9. FOAM SHEETS

9.1. FOAM SHEETS KIT FOR MAIN TUBE

Ref. 099.25088



10. BOSCH SYSTEM CONTROLLER KIOX 400

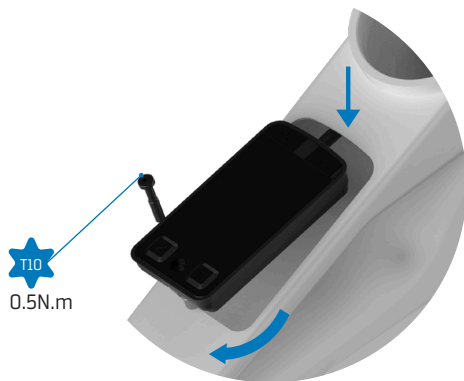

11. BOSCH MINI REMOTE

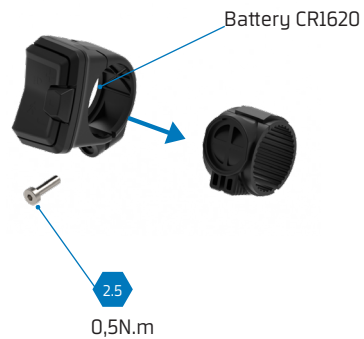

12. CHAINSTAY PROTECTOR



Chainstay protectors come without a hole for mechanical or cable-operated derailleurs. There is a mark on the rear for piercing the cable outlet.

For the best results, we recommend using punch pliers.



13. RANGE EXTENDER BOSCH POWERMORE KIT

EU28, CH, NO, AUS, NZ

POWERMORE 250 KIT (BBP3620 EU28,CH,NO,AUS,NZ)
incl. battery holder, bottle holder, screws, IBD packaging
EB12.100.05G

US, CANADA

POWERMORE 250 KIT (BBP3625 US, CAN) incl.
battery holder, bottle holder, screws, IBD packaging
EB12.100.05H



CABLE POWERMORE 150MM (BCH3923_150) **EB12.120.036**



14. MUDGUARDS

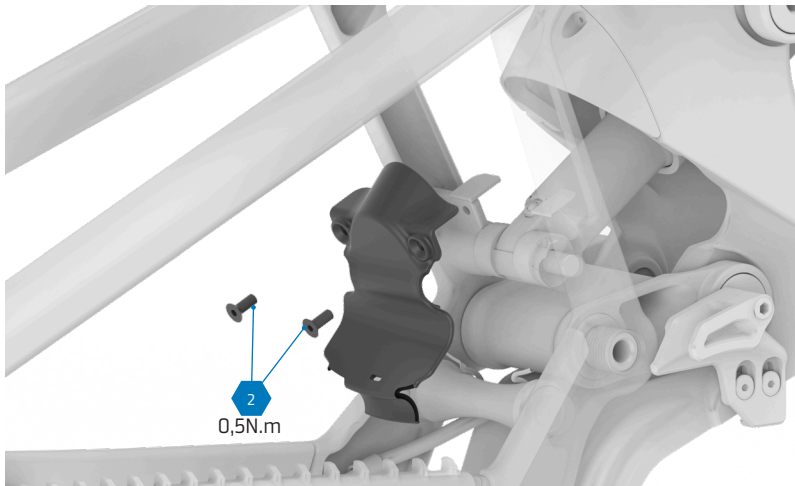
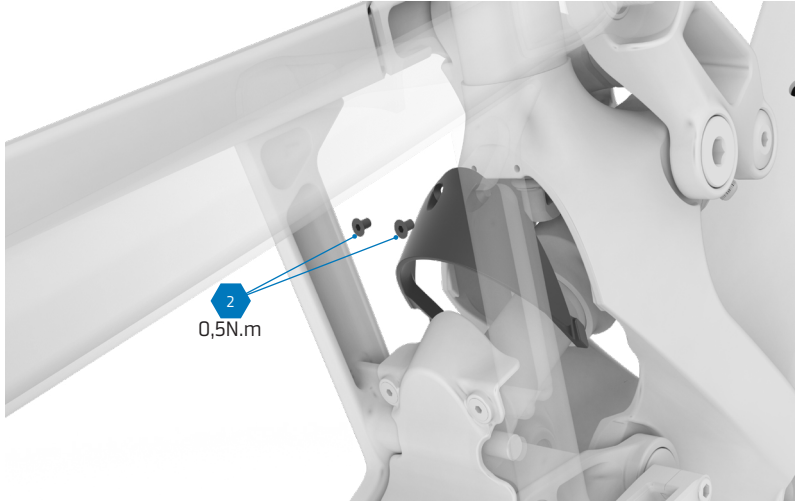

15. SEATPOST CLAMP

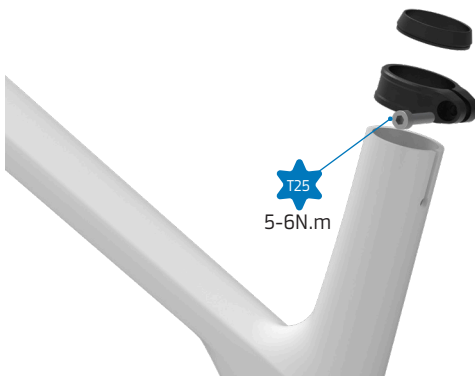

We recommend using
carbon friction paste on the
seatpost



16. UPPER LINK INSTALLATION GUIDE

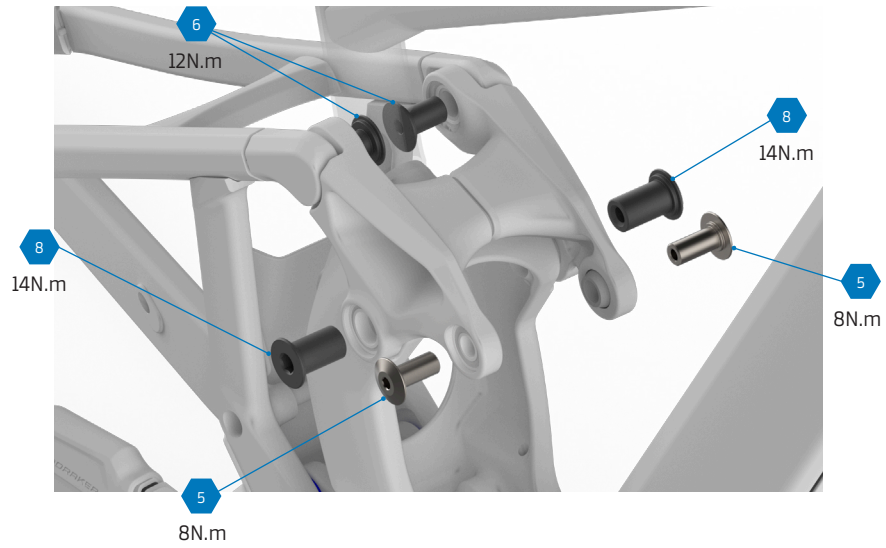

Apply grease to the shaft for the main screws and Loctite 243 or similar to the threads.

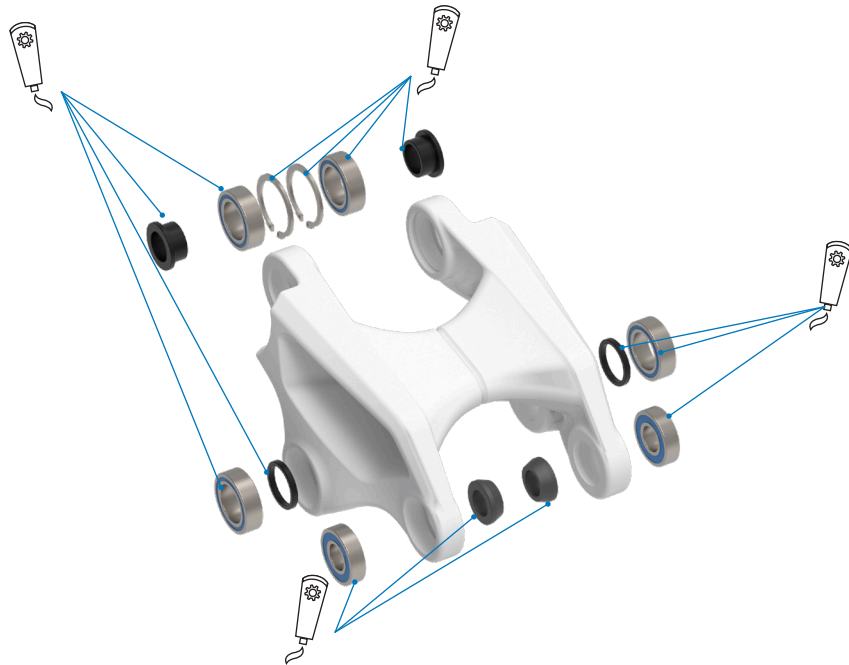

Apply grease.



17. LOWER LINK INSTALLATION GUIDE

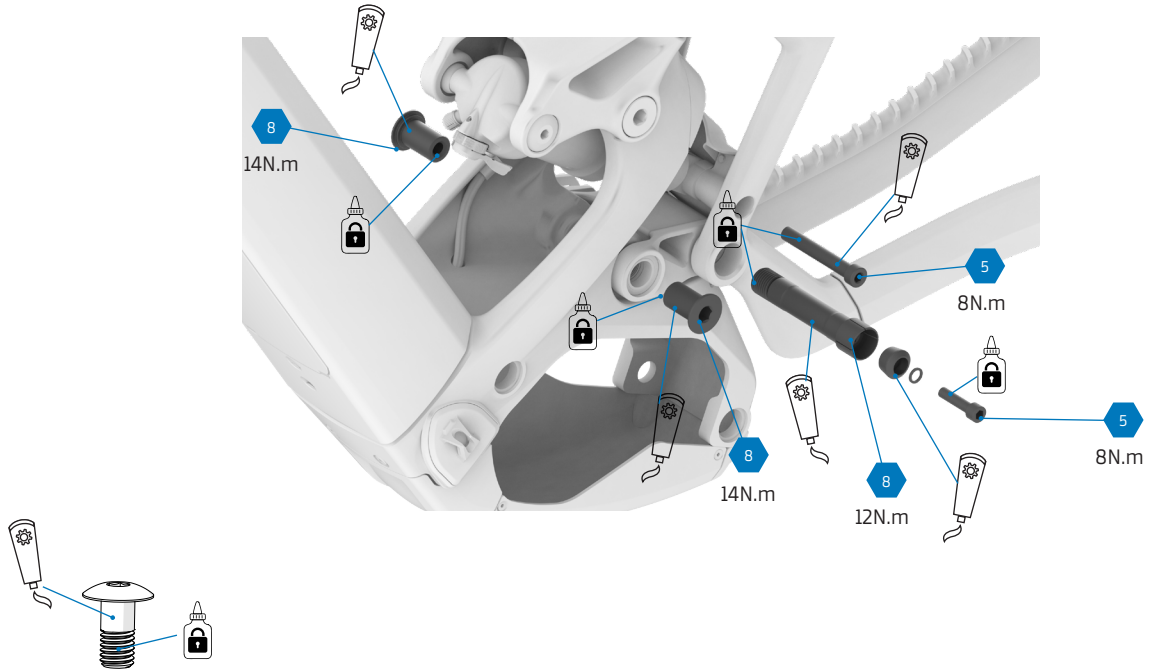

Apply grease to the shaft for the main screws and Loctite 243 or similar to the threads.



Apply grease.

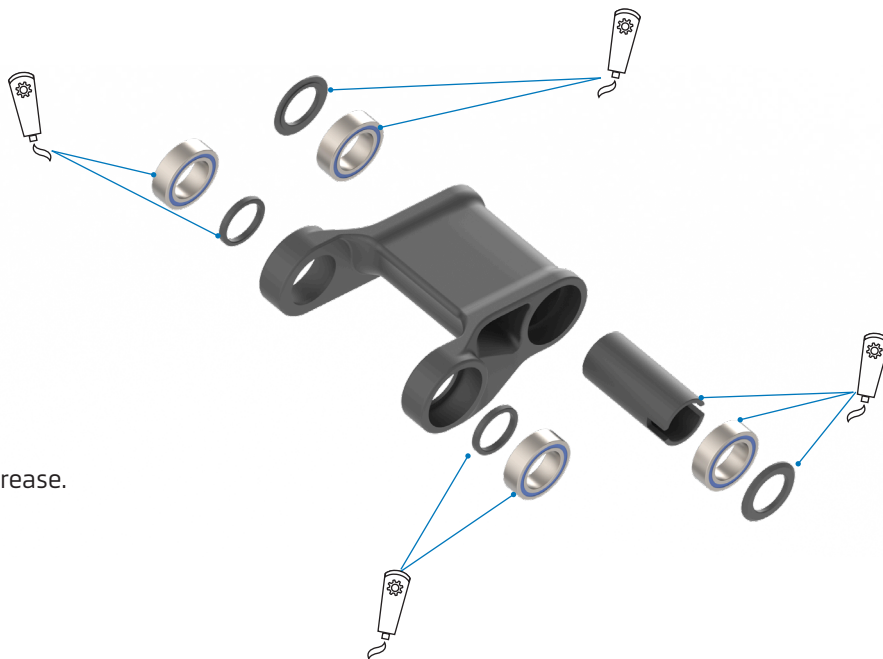



19. SMARTPHONE CONNECTION



eBike Flow app



Switch on the bike.

After switching on, press and hold the power button for 5 seconds until a blue LED starts flashing.

Then, open the eBike Flow app and follow the pairing instructions on your Smartphone.



20. STEM INSTALLATION

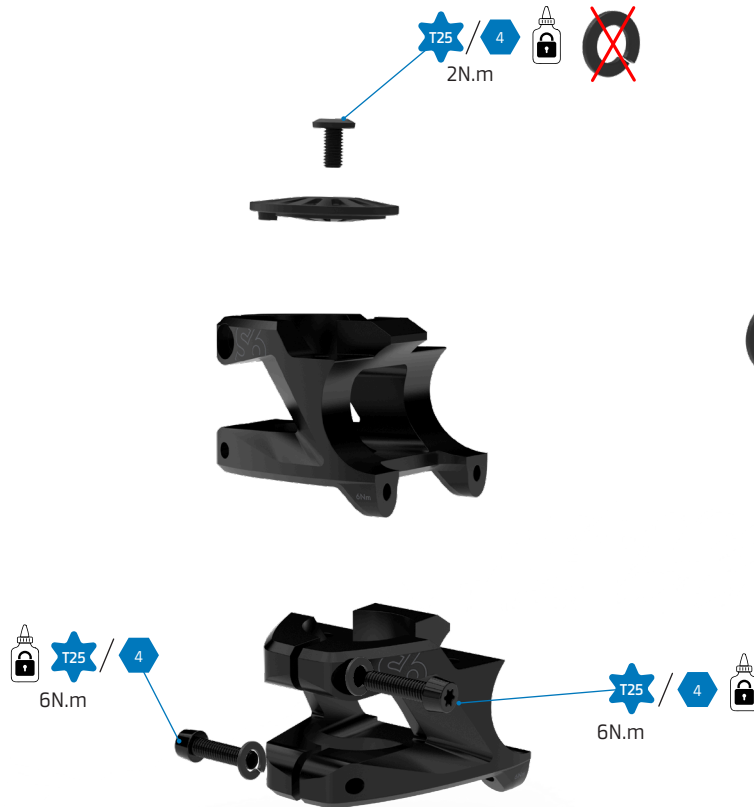

The 6 stem bolts, except for the headset top cap bolt, must be fitted with a split lock washer.

1. Stem insertion

Slide the stem body onto the fork steerer tube until it is properly seated.

2. Headset adjustment (Preload)

Place the headset top cap and its corresponding bolt. Tighten the upper bolt to a maximum torque of 1 Nm to preload the bearings and eliminate any play in the headset.

3. Tightening the side pinch bolts

Align the stem with the front wheel. Tighten the side pinch bolts gradually, alternating between them to distribute the load. Increase the tension progressively (e.g., upper to 4 Nm, lower to 4 Nm, then both to 5 Nm) until both bolts reach the exact final torque of 6 Nm.

Assembly tip:

It is visually easier to align the stem with the front wheel if the handlebar is already installed. To do this, perform this step applying only light tension to the side bolts, proceed to Handlebar installation (Section 2), perform the final alignment of the entire assembly, and finally apply the definitive tightening torque of 6 Nm to the fork's side pinch bolts.



21. HANDLEBAR INSTALLATION

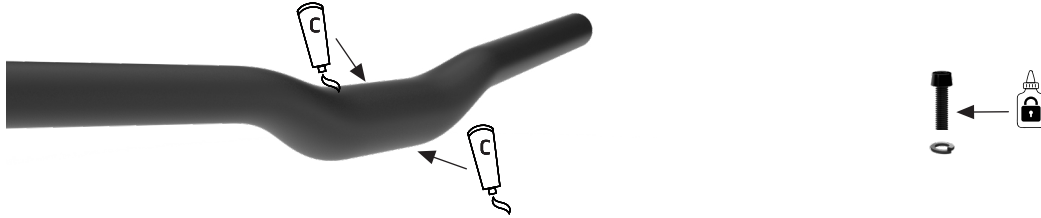

Apply a thin layer of carbon-specific assembly paste on the contact area between the handlebar and the stem. If the screw threads are dry, apply a small drop of LOCTITE 243.

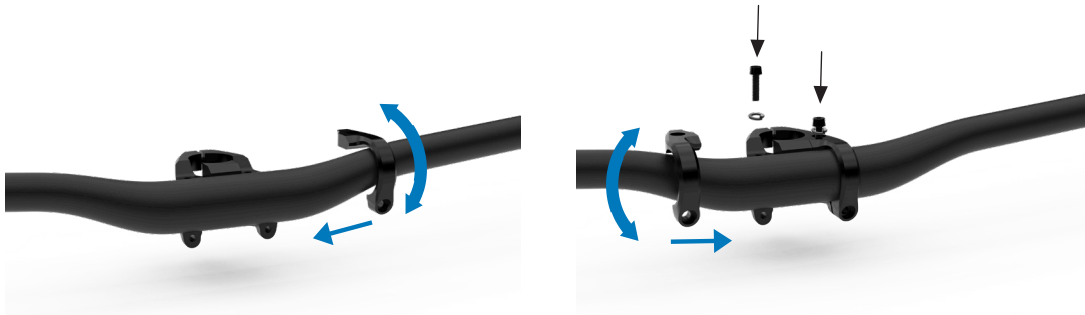

Slide the stem faceplate from the narrowest part of the handlebar towards the center, being careful not to scratch the component's surface. Adjust it and insert the upper bolt to hold it in place. Do not tighten to the final torque.



Place the two upper screws and thread them in a few turns by hand without applying the final tightening torque. Next, insert the two lower screws without tightening them.

Note: If it is difficult to align or thread the lower screws, slightly loosen the upper ones to ease insertion and try again.



21. HANDLEBAR INSTALLATION

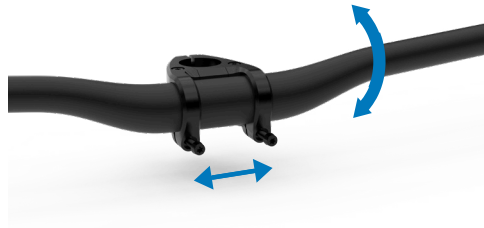

Adjust the rotation and centering of the handlebar until the desired position is reached.

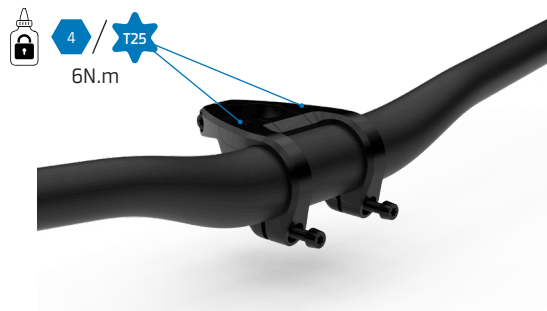

Tighten the upper bolts gradually, alternating between sides. Increase the tension progressively (e.g., 4 Nm, then 5 Nm on each side) until the exact final torque of 6 Nm is reached. It is critically important that both upper bolts are fully tightened to 6 Nm in this step.

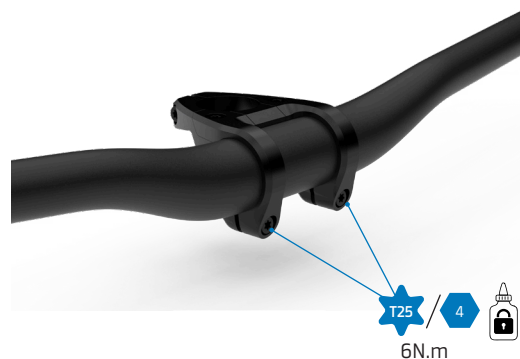

With the handlebar in its final position, tighten the lower bolts gradually, alternating between the left and right sides (4 Nm, 5 Nm, and finally 6 Nm) to distribute the load evenly.

Visually verify the correct engagement of the stem. By design, there must be no gap between the parts at the top; the clamping gap must remain exclusively at the bottom. Finally, check with a torque wrench that all four bolts maintain the specified torque of 6 Nm. Wipe away any excess grease.



DETAIL 01

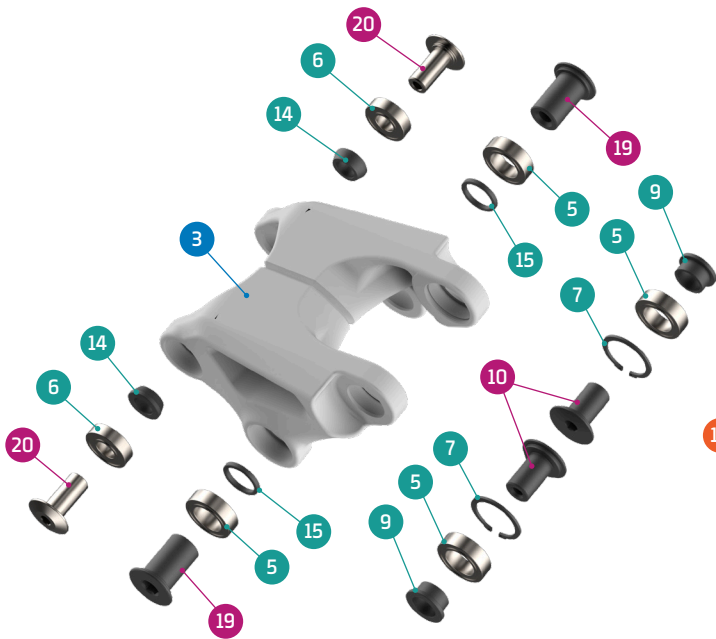

DETAIL 02

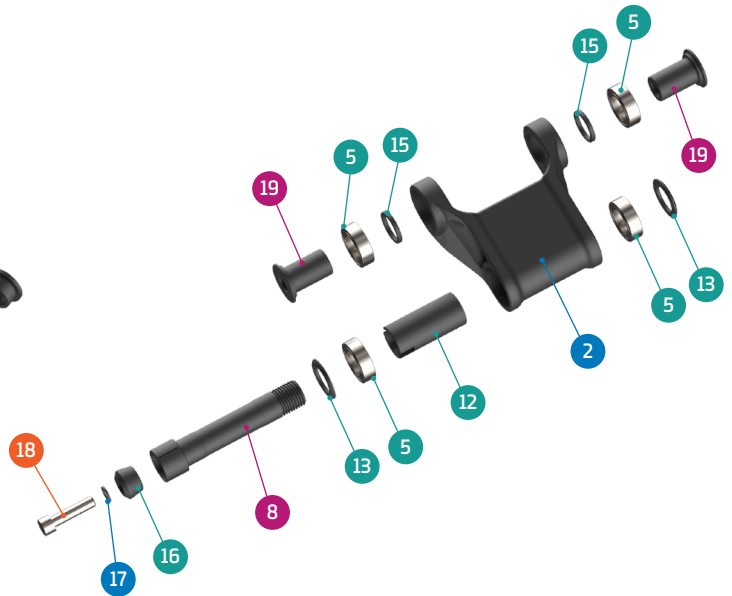

FOAM FOR BATTERY (600WH)

FOAM FOR MAIN TUBE

FOAM FOR BATTERY COVER

SET 7

SET 6



CABLE GUIDE KIT

DISC ADAPTOR KIT

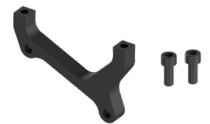

SET 1

SET 2

SET 3

SET 4

SET 5

ZERO BEARING KIT 26

SHOCK HARDWARE KIT 22

UPPER LINK KIT 30

LOWER LINK KIT 37

CHAIN GUIDE PLATE + BOLTS

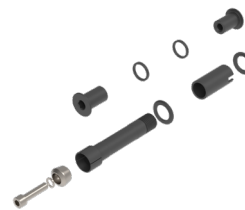

PART NUMBER	DESCRIPTION	COMPONENTS
099.22101	SET 1: ZERO BEARING KIT 26	BEARING 3802-2RS, 24x15x7 (x8) / BEARING 6900V-2RS, 10x22x6 (x2)
099.24200	SET 2: SHOCK HARDWARE KIT 22	SPACER (x2) / SHOCK BOLT (x2) / SHOCK BOLT (x1)
099.22300	SET 3: UPPER LINK KIT 30	SPACER, 15x19x2.5T (x2) / UPPER LINK-RT SPACER (x2) / PIVOT AXLE, M12 (x2) / PIVOT AXLE, M15 (x2) / C-RING (x6)
099.25400	SET 4: LOWER LINK KIT 37	SPACER, 15x27x2 (x2) / SPACER, 15x19x2.5t (x2) / INNER LOWER LINK SPACER (x1) / PIVOT AXLE, M10 (x1) / AXLE NUT, M10 (x1) / MAIN AXLE (x1) / SPACER (x1) / TAPER NUT (x1) / SCREW BOLT (x1)
099.24018	SET 5: CHAIN GUIDE PLATE + BOLTS	CHAIN GUIDE BASE (x1) / CHAIN GUIDE OUTER PLATE (x1) / SCREW BOLT, M5x12 (x2) / SCREW BOLT, M5x8 (x1) / WASHER 5x9x1t (x4)
099.25018	SET 6: DISC ADAPTOR KIT	DISC ADAPTOR (x1) / SCREW BOLT (x2)
099.25013	SET 7: CABLE GUIDE KIT	CABLE GUIDE (x1) / SCREW BOTL M2.5X5L (x1) / SCREW BOLT M3X10L (x1)
099.25088	FOAM KIT FOR MAIN TUBE	
099.25089	FOAM FOR BATTERY COVER	
099.25097	FOAM FOR 600Wh BATTERY	



23. FAQs

WHAT IS THE DIFFERENCE BETWEEN THE NEW SCREE AND CRAFTY CARBON?

Both Scree and Crafty Carbon are Mondraker's most versatile eMTBs but each feature different intended use where frames, kinematics, geometry and suspension travel are different between both models. Scree is an all-new fully dedicated Trail model with 130mm rear wheel travel and 150mm front Stealth alloy frameset, while Crafty Carbon is an Enduro model with longer 150mm rear 160mm front travel featuring Stealth Air Carbon frameset. Both share Bosch Performance CX Gen 5 latest motor and either 600Wh or 800Wh batteries. Both families are available in 5 sizes with dedicated geometry for each one. Both spec the latest generation of Bosch's Performance CX motor with up to 100Nm and 750W compatible with 800Wh and 600Wh batteries for the greatest riding experience.

HOW MUCH DOES THE NEW SCREE FRAME WEIGH?

Scree painted frame complete with hardware and accessories without rear shock in ML size is around 4,900 kg.

HOW MUCH LIGHTER IS THE 600WH BATTERY COMPARED TO THE 800WH ONE?

Powertube 800Wh is 3.990 grams and the new Powertube 600Wh is 3.070 grams and both feature the latest generation 21700 battery cells.

WHICH SHOCKS ARE COMPATIBLE WITH THE NEW SCREE?

Scree is compatible with any inline shock and its kinematic design has been optimized to be ridden with inline shocks. You can also use piggyback style models such as Float X series or RockShox SuperDeluxe. For anything bigger in volume it's mandatory checking before installing as they might not fit. Scree feature metric 165x45mm sized shocks with Trunnion upper mount and bottom 30x8 mm standard hardware.

WHICH KINEMATIC FEATURES OFFER THE ALL NEW SCREE?

Zero Suspension design and layout has been updated and improved following the latest performance evolutions seen on other latest generation Mondraker full suspension bikes, in this case, tailored for the most versatile Trail intended use. Scree feature a 20,5% progression rate, higher leverage ratio becoming more supple and sensitive off the top, feature a slightly lower anti-squat and anti-rise curves for a more capable and better overall performing rear suspension.

WHICH IS THE MAXIMUM FORK TRAVEL ON THE NEW SCREE?

Scree is compatible with forks up to 160 mm travel or 580mm axle to crown.

IS IT POSSIBLE TO RUN A LARGER 220MM REAR BRAKE ROTOR ON SCREE?

Yes, Scree is compatible with larger rear brake rotors of 220mm. This is something we don't really recommend, but it's possible to fit them on the Crafty Carbon models.

WHICH IS THE MAXIMUM TIRE WIDTH THAT CAN FIT ON SCREE?

Scree is compatible with tires up to 66mm wide which translate into 29"x 2.6" tires. It is recommended to measure the tire before installing as the real width might be different depending on the manufacturer.



23. FAQs

IS SCREE COMPATIBLE WITH 27,5 REAR WHEEL?

You could technically ride a smaller 27,5" rear wheel but the bike has not been designed to ride a mullet setup and the motor would not offer the optimum performance as wheel diameter is altered. The smaller wheel circumference will affect the accuracy of the speed reading and cannot be adjusted. For example, switching to a 27.5 x 2.6" rear wheel and tire combination will reduce cut-off speed by about 1 or 2 km/h.. and probably with the magnet speed sensor on the rear smaller diameter wheel the motor might not work properly. Scree geometry will be compromised as well with angles changing -1.5° and bottom bracket dropping -13/-15mm and, more importantly, Mondraker does not cover the warranty riding anything different from the stock 29" rear wheel.

WOULD IT BE POSSIBLE TO ADD A BATTERY EXTENDER TO INCREASE THE RANGE AND RIDE LONGER?

Yes, as on any of the latest Bosch's motor systems, there is a Bosch Powermore 250Wh range extender "water-bottle" mount style. It weighs 1.450 grams or 1.525 grams including Bosch's side-specific mounting bracket and connecting cable. You will enjoy longer range compared to the internal 600Wh (+40%) or 800Wh (+30%) Powertube batteries.

WHAT IMPORTANT CONSIDERATIONS I SHOULD CONSIDER WHEN FITTING A POWERMORE?

Bosch offers different sizes of the connecting cable for the Powermore range extender, you will need the 150mm length for all Scree models and bike sizes. Bosch part number is: BCH3923_150 / EB12.120.036. It's also important to note that there exist 2 Powermore types that you have to consider depending on where you live: PowerMore, EU28,CH,NO,AUS,NZ (Bosch part number BBP3620 / EB12.100.05G) and US, CAN, KOR (Bosch part number BBP3625 / EB12.100.05H)

CAN I CARRY A WATER BOTTLE?

Yes you can. There are 2 possible locations for a water bottle cage, in the main frame, the standard position as on any other bike and below the top tube.

CABLE ROUTING IS EXTERNAL THROUGH THE HEADTUBE SIDES, IS IT POSSIBLE TO RUN THE CABLES INTERNALLY THROUGH THE HEADSET AS ON OTHER MODELS?

Yes you can. The new headset upper cup is ready to route the cables through it and run a completely internal guiding if you prefer it this way.

IS IT POSSIBLE TO DISASSEMBLE THE INTERNAL BATTERY?

Yes. New Scree allow to easily remove the internal battery. It's very simple just undo the top 5 mm allen bolt on the upper bottom side of the main tube and the battery will come off to charge it outside the bike, change it or simply cleaning or perform bike maintenance.

THERE ARE 2 BATTERY SIZES 800WH AND 600WH, CAN I FIT ANY OF THEM IN THE SCREE?

Yes. All Scree models allow to either run the Powertube 800Wh or the 600Wh batteries. If your bike comes with one or the other, you can buy a spare one and fit it on your bike depending on your preferences. Make sure you also get the required adaptors (to fit both, the smaller sized 600Wh in case your bike comes stock with the 800Wh and the other way around as battery heights are different as so are the adaptors) to fit it properly inside. Additionally, you would want to buy an extra battery cover from your Mondraker dealer (this way you'd have 2 swappable ready to go batteries) or technically disassemble the stock one bolted into the stock battery and install it on the new one, but the foam inside between both 600 and 800 battery options is not the same either. Older and heavier 750Wh and 625Wh batteries could perfectly work on the new Scree models but Mondraker does not supply the adaptors required to fit them with these new frames. Bike would also work with the Powermore range extender and no internal battery but Bosch do not recommend it or the bike is intended to be ridden only with the range extender as its name suggests.



23. FAQs

HOW LONG DOES IT TAKE TO FULLY CHARGE THE BATTERY?

The Powermore 800Wh battery takes around 6h to be fully charged while the 600Wh takes around 4,5h if fully discharged.

If you have a PowerMore range extender, it needs to be charged individually separately and takes around 2,5 hours to be fully charged.

ARE THERE ANY SPECIAL DIRECTIONS OR CONSIDERATIONS FOR THE BATTERY?

Nothing special. You can control the remaining battery life at the Kiox 400c display on the top tube. When there is 30% battery life remaining motor assistance will be slightly reduced which will be more noticeable when 10% battery left is reached. No special directions or considerations whatsoever.

SRAM LATEST GENERATION T-TYPE REAR DERAILLEURS CAN WORK DIRECTLY PLUGGED INTO THE BIKE'S MAIN BATTERY, IS IT POSSIBLE TO DO SO HERE WITH THE SCREE MODELS?

Yes you technically can, you would need to buy the proper accessories and run the charging cable internally to the main battery to do so.

MY SCREE FEATURES A SRAM T-TYPE TRANSMISSION, WOULD IT BE POSSIBLE TO RUN A SHIMANO DRIVETRAIN AND REAR DERAILLEUR?

Yes, totally. Just make sure you'd need an additional UDH derailleur hanger for the Shimano rear derailleur.

WHICH IS THE MAXIMUM ASSISTANCE I CAN GET FROM THE SCREE'S BOSCH PERFORMANCE CX MOTOR?

The stock (BDU384Y) Performance CX motor from Bosch offers 85Nm and 600W of peak power. Via Bosch's Flow app you can upgrade motor output up to 100Nm and 750W peak power.

IS IT POSSIBLE TO CUSTOMIZE THE ASSISTANCE MODES ON THE SCREE?

You can customize Scree's Bosch Performance CX motor assistance modes the same way as other motor systems in Bosch's motor lineup with the Flow App. Log in the Flow App, turn the bike on and connect to your Scree to customize the motor output Support, initial pedaling assistance through Dynamic, maximum kms/h / mph with the 25kms/h / 20mph assistance and 100 max Nm torque individually on the 4 support modes ECO, TOUR+, EMTB+ and TURBO. You can also modify the assistance modes to your liking, use all 4 or less if you prefer.

HOW LONG CAN I RIDE WITH THE NEW SCREE?

This is always a tricky question and also depends on the level of assistance you are using, rider fitness, rider weight and riding conditions. With the new PT800Wh battery an average rider with 80 kgs riding weight can climb around 2.000m/6.500ft elevation gain (1.500m/5.000ft with PT600Wh battery) combining different support modes and ride as much as 4 hours in ECO-TOUR+ modes. Again, depending on riding conditions and rider physical level. The 250Wh PowerMore range extender would increase +30% (with PT800Wh battery) / +40% (with PT600Wh battery) riding time / distance with only 1.5 kg extra weight.

RIDING WITH THE POWERMORE RANGE EXTENDER, WHICH BATTERY IS DISCHARGED FIRST, THE INTERNAL ONE OR THE EXTENDER?

To maintain the proper power output from the motor, both batteries discharge at the same time. This is key for proper battery life and constant motor assistance. If you install a Powermore when you are running out of the internal battery, the Powermore will be used as the main battery supply until both charges (internal and extender) are equal and then, both will be equally discharged until fully drained.



All information and pictures on this document is provided for information purposes only and does not constitute a legal contract between Mondraker and any person or entity. Specifications, geometries or any other technical information published is subject to change without prior notice.

© ® All trademarks and models are property of Blue Factory Team, S.L.U. and are protected by current laws and applicable international agreements.

ANLEITUNGEN UND DOKUMENTE





SICHERHEITS- UND ALLGEMEINE HINWEISE

Bitte beachten Sie, dass in diesem technischen Leitfaden die folgenden drei Symbole erscheinen können. Sie weisen jeweils auf die folgenden Vorsichtsmaßnahmen hin:

WARNUNG:

Die Nichtbeachtung dieser Hinweise oder die Durchführung unsicherer Praktiken kann zu schweren Verletzungen oder sogar zum Tod führen. Die Arbeiten sind technisch anspruchsvoll und können bei fehlerhafter Ausführung zu Schäden am Fahrrad oder zum Erlöschen der Garantie führen.

VORSICHT:

Die Nichtbeachtung dieser Hinweise oder die Durchführung unsicherer Praktiken kann zu leichten Verletzungen führen. Die Arbeiten sind technisch anspruchsvoll und können bei fehlerhafter Ausführung zu Schäden am Fahrrad oder zum Erlöschen der Garantie führen.

INFORMATION

Informationen, die für eine ordnungsgemäße Ausführung der Arbeit wichtig sind und daher mögliche Schäden an Ihrem Fahrrad oder den Verlust der Garantie verhindern. Hier besteht jedoch kein Risiko für Personen.

WICHTIGE HINWEISE

- Die Verwendung von nicht originalen Ersatzteilen kann zu Schäden, Fehlfunktionen und Unfällen mit schweren Folgen führen.
- Bitte beachten Sie, dass für einige der in diesem Handbuch beschriebenen Arbeitsschritte Kenntnisse erforderlich sind, die über die Kompetenz eines durchschnittlichen Fahrradfahrers hinausgehen. Falls Sie nicht qualifiziert sind, diese Schritte auszuführen, bringen Sie Ihr Fahrrad zur Wartung und zum Austauschen von Bauteilen zu einem von Mondraker autorisierten technischen Kundendienst. Der falsche Einbau von Ersatzteilen kann zu Fehlfunktionen, Unfällen, Verletzungen und zum Erlöschen der Garantie führen.

REINIGUNG UND PFLEGE

- Nach einem Ausbau der Teile wird empfohlen, die wiederzuverwendenden Komponenten zu reinigen, zu fetten und (falls erforderlich) mit Schraubensicherung zu versehen.

SYMBOL-LEGENDE



Mittelfeste Schraubensicherung. Loctite 243 oder ähnlicher Art.



Synthetische Montagepaste.



Spezielle Carbon Montagepaste.



1. GEOMETRIE

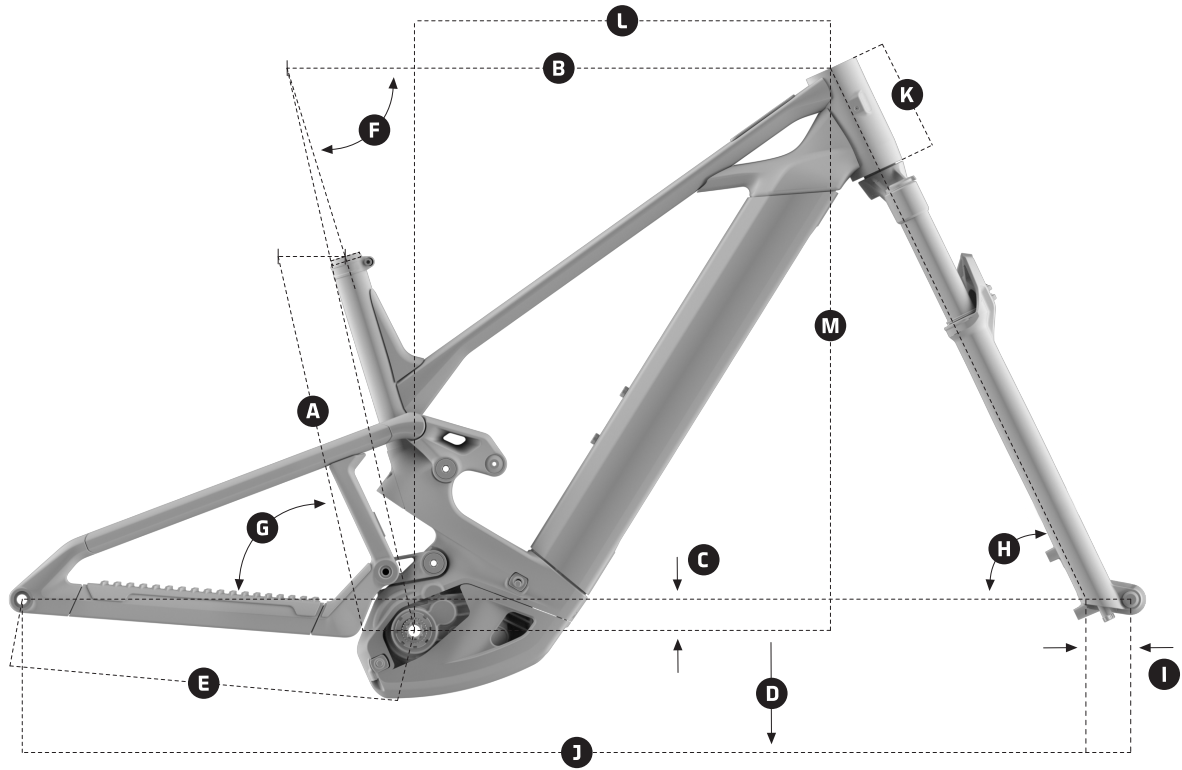

SCREE

	RAHMENHÖHE	S	M	ML	L	XL
A	Sitzrohrlänge	380 mm	410 mm	435 mm	460 mm	490 mm
B	Oberrohrlänge	587,6 mm	607,6 mm	628,8 mm	650,7 mm	672,8 mm
C	Innenlagerabsenkung	-35 mm	-35 mm	-35 mm	-35 mm	-35 mm
D	Innenlagerhöhe	340 mm	340 mm	340 mm	340 mm	340 mm
E	Kettenstredenlänge	456 mm	456 mm	456 mm	456 mm	456 mm
F	Sitzwinkel	74°	74°	74°	74°	74°
G	Sitzwinkel (effektiv)	77°	77°	77°	77°	77°
H	Lenkwinkel	65,5°	65,5°	65,5°	65,5°	65,5°
I	Gabel Offset	44 mm	44 mm	44 mm	44 mm	44 mm
J	Radstand	1221,2 mm	1241,2 mm	1263,3 mm	1287,4 mm	1311,5 mm
K	Steuerrohrlänge	125 mm	125 mm	130 mm	140 mm	150 mm
L	Reach	440 mm	460 mm	480 mm	500 mm	520 mm
M	Stack	644,6 mm	644,6 mm	649,2 mm	658,3 mm	667,4 mm



2. RAHMENSPEZIFIKATIONEN

RAHMENGRÖSSEN	S / M / ML / L / XL
VORDERRADGRÖSSE	29"
NABE VORN	110mm x 15mm (BOOST)
HINTERRADGRÖSSE	29"
NABE HINTEN	148mm x 12mm (BOOST)
HINTERACHSE	12X148 P1.0 L180
ANZAHL WASSERFLASCHEN	2 POSITIONEN, 1 WASSERFLASCHE / RANGE EXTENDER
MOTOR	BOSCH PERFORMANCE LINE CX
INNENLAGER	BOSCH
AKKU	800Wh / 600Wh
POWER RANGE	BOSCH POWERMORE 250Wh
FEDERWEG	130mm
SCHOCKABSORBER	165 x 45mm TRUNNION, 30 x 8mm
FEDERGABEL	150mm
DURCHMESSER SATTELSTÜTZE	31.6mm / 34.9mm
KETTENLINIE	55mm
STEUERSTAZ	ZS56 / ZS56, 1-1/8", 1.5"
KETTENBLATT MAX	34T
BREMSE HINTEN	POST MOUNT, DIRECT 220mm max
MAXIMAL KOMPATIBLE REIFENGRÖSSE	29" x 2.6" (66-622)

3. EINSTECKTIEFE DER SATTELSTÜTZE

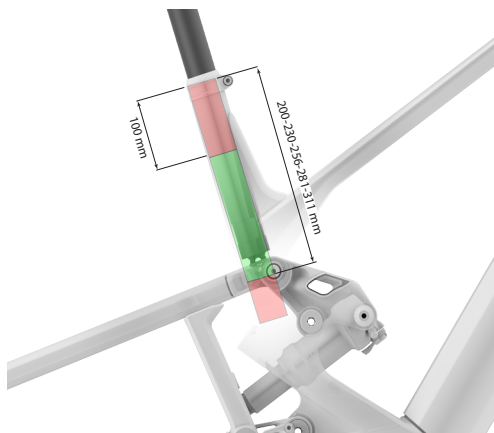

RAHMENGRÖSSE	MIN. (mm)	MAX. (mm)
XL	100	311
L	100	281
ML	100	256
M	100	230
S	100	200



4. BAUTEILE ANTRIEB

4.1. KETTENFÜHRUNG

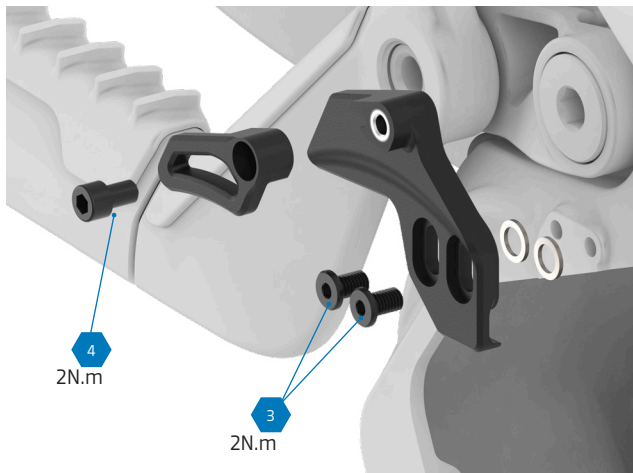

4.2. KETTENBLATT



Schlagen Sie im Handbuch des Herstellers nach, ob Ihr Kettenblatt mit einem O-Ring kompatibel ist.

5. MOTORABDECKUNG

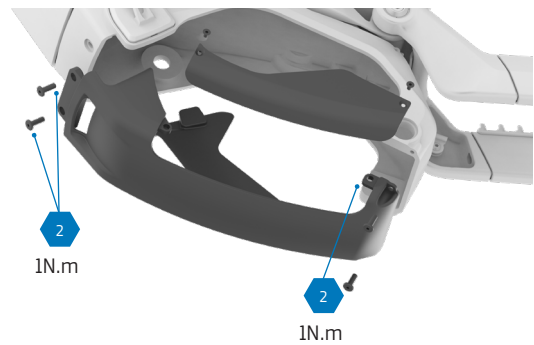
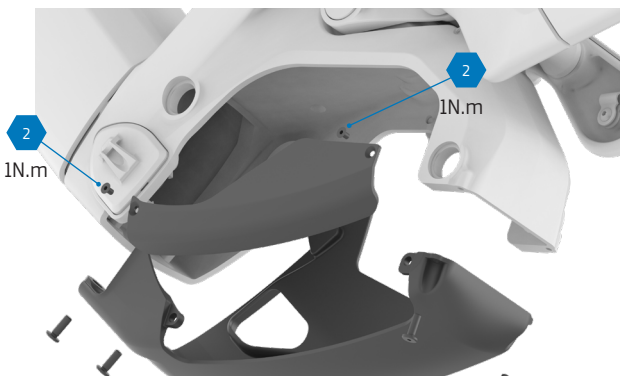



6. MOTOR AUSBAUEN



Kein Loctite 243 verwenden^o

6.1. MOTORANSCHLÜSSE

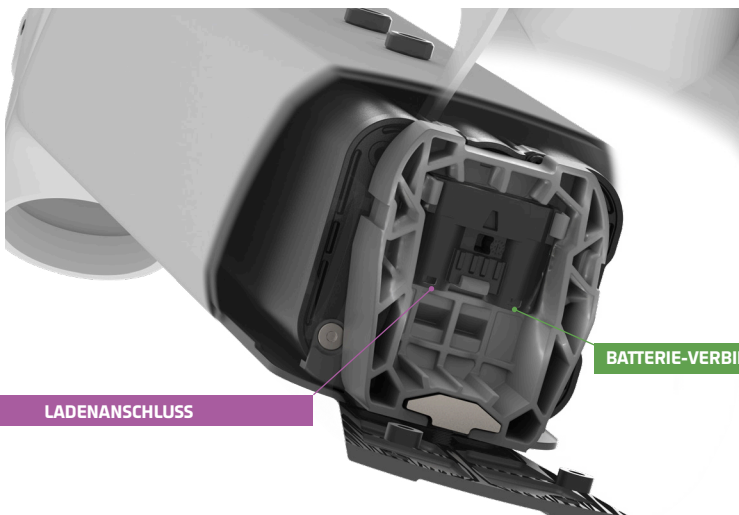
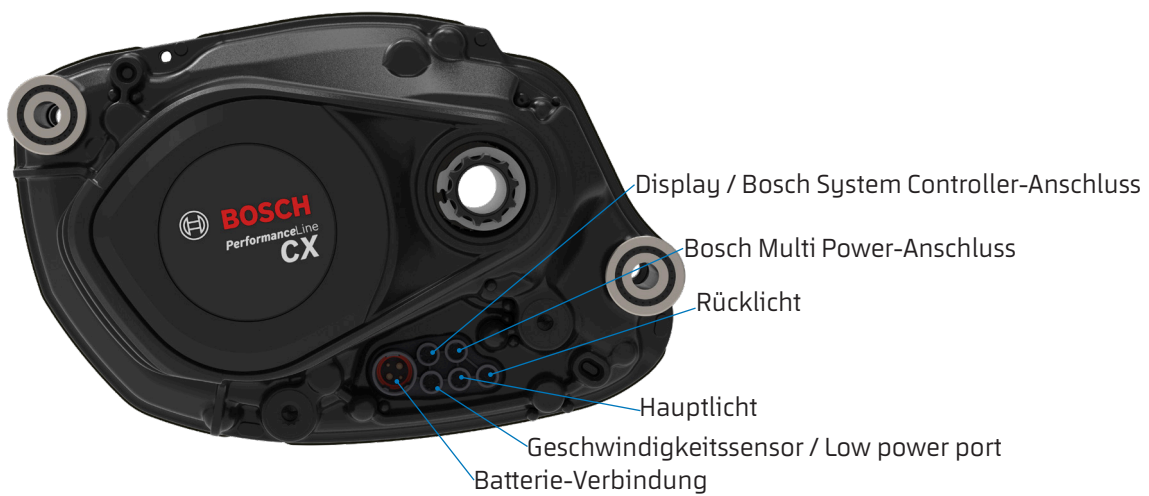

LADENANSCHLUSS

BATTERIE-VERBINDUNG



7. LADEANSCHLUSS

7.1. LADEANSCHLUSS ENTFERNEN

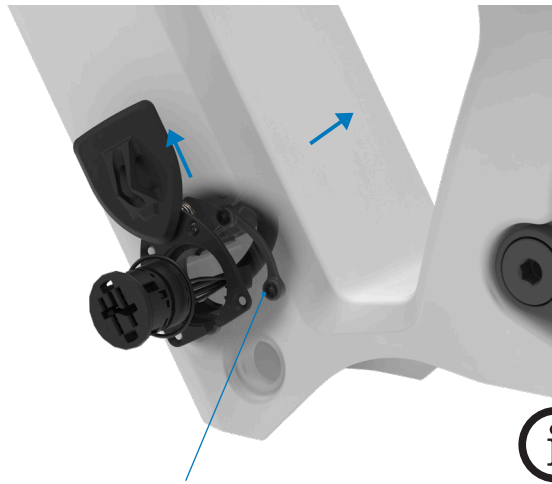
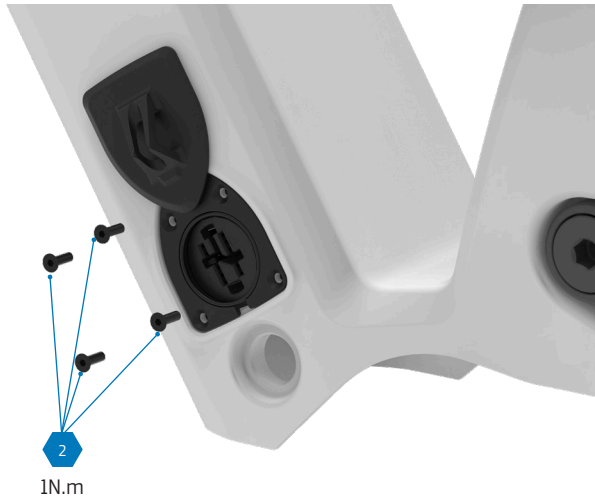

Abdeckung von der Seite lösen



Die 2 unteren Metallbefestigungen sind innen im diagonalen Rohr zu sehen.





8. AUSBAU DES AKKUS

SCHRITT 1

Löse die Schraube bis zum Ende des 1. Teils des Gewindes. Der Akku klappt jetzt ein Stück weit heraus, ist aber durch den 2. Teil des Gewindes im Rahmen gesichert.

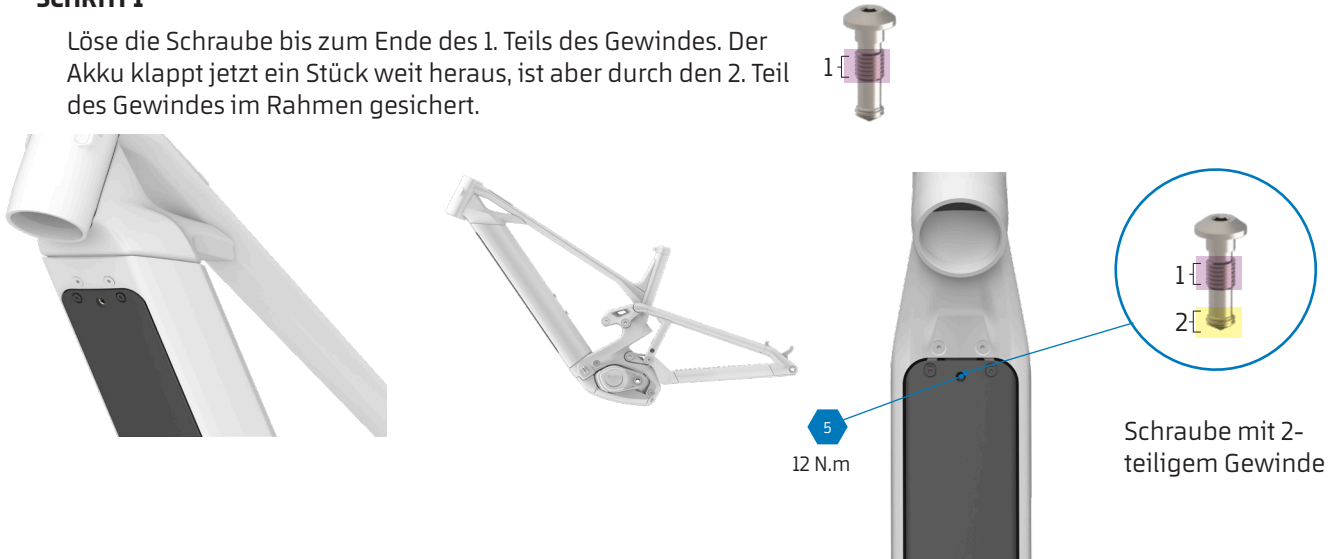

ENDE VON SCHRITT 1

Halte nun den Akku mit einer Hand sicher fest und löse den 2. Teil des Gewindes, um den Akku zu entsichern.



SCHRITT 2

Der Akku ist nun entsichert und kann herausgenommen werden. Achtung: der Akku ist schwer und kann beim Herausfallen dauerhaft beschädigt werden oder dich verletzen.

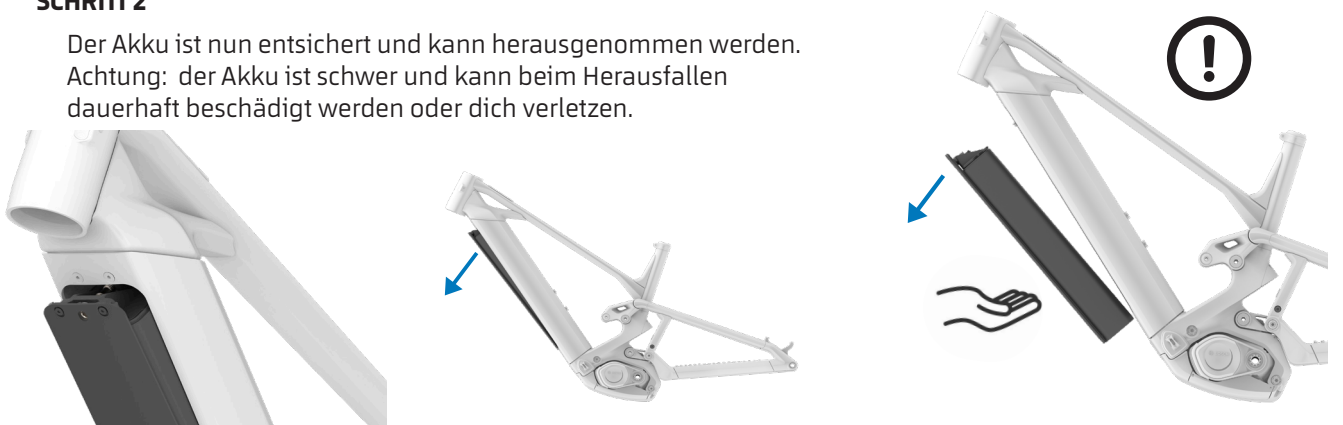



9. INTERNE KABEL- UND ZUGVERLEGUNG

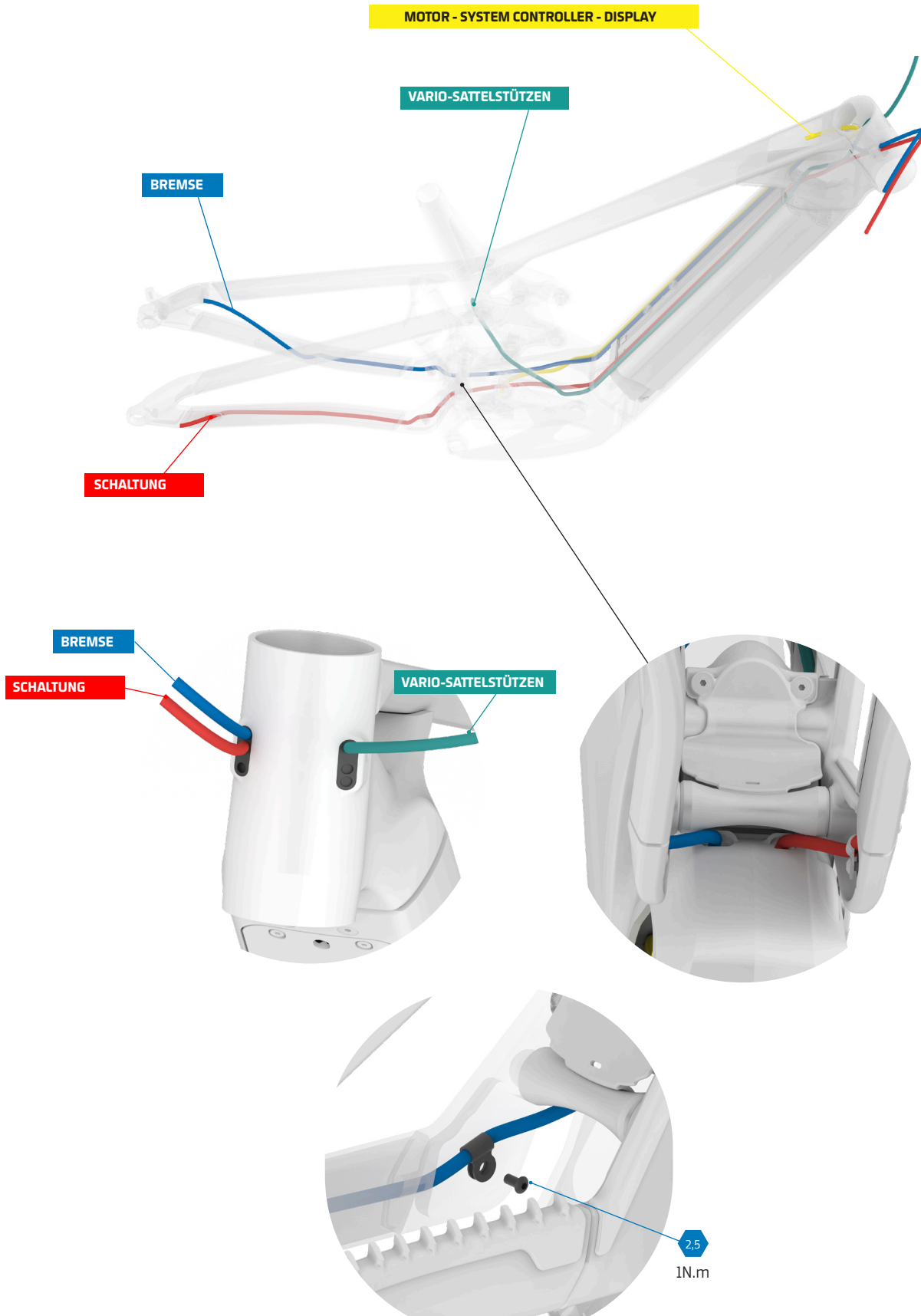



10. AKKUVERANKERUNG

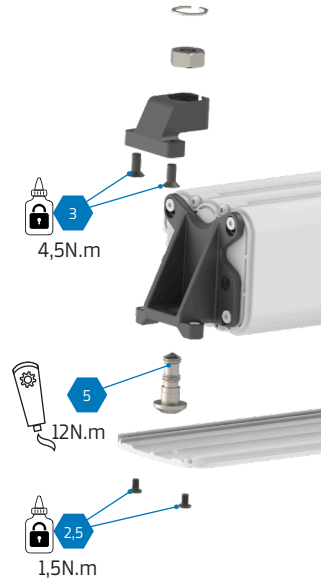
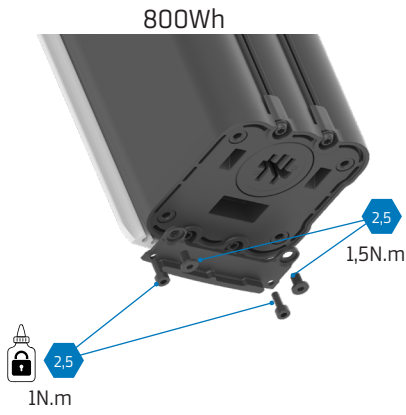
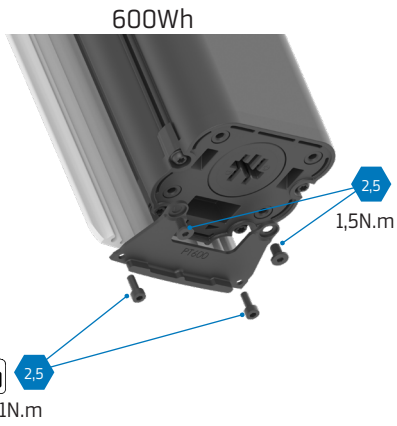
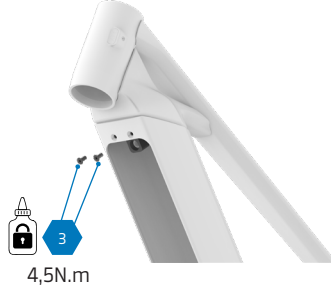



11. BATTERIEUMBAU 600 WH / 800 WH

11.1 EINSETZEN DER BATTERIEVERBINDUNGEN

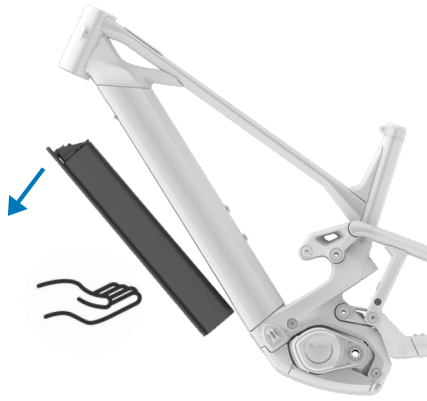

600Wh



800Wh

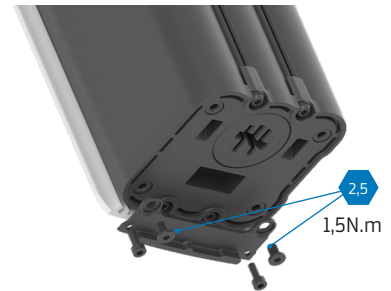

600Wh

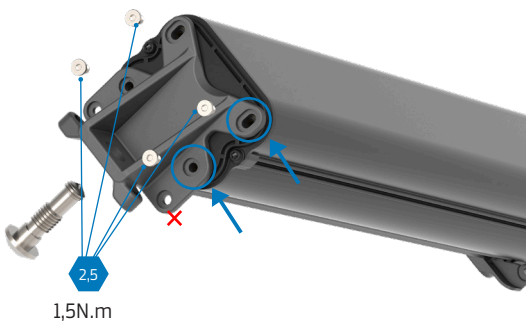

800Wh

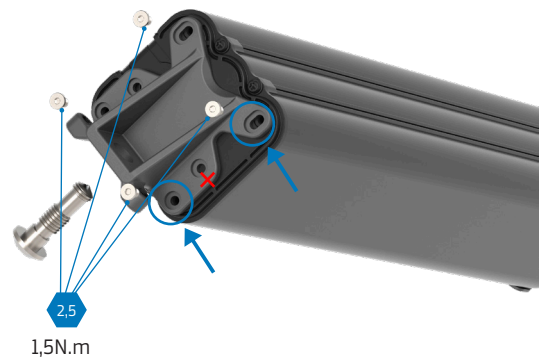



11. BATTERIEUMBAU 600 WH / 800 WH

11.2. EINSETZEN DER BATTERIEABDECKUNG

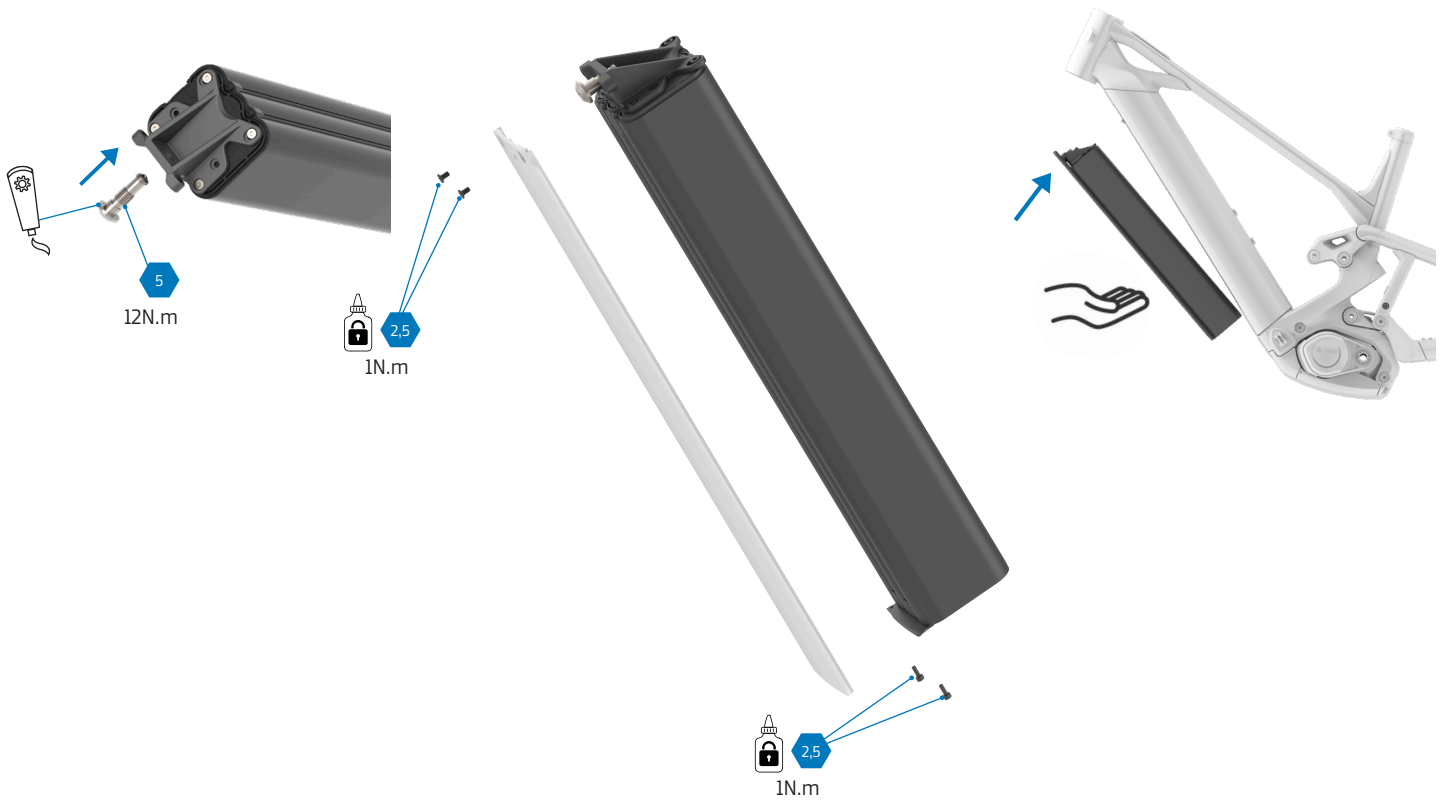

8. 4. REFERENZEN



BATTERIEHALTERUNG
VORNE 800Wh/600Wh
Ref. 099.25049



HINTERE
BATTERIEHALTERUNG
800Wh
Ref. 099.26020



HINTERE
BATTERIEHALTERUNG
600Wh
Ref. 099.26021



8. 5. BENÖTIGTE ERSATZTEILE FÜR EINE ZWEITE BATTERIE

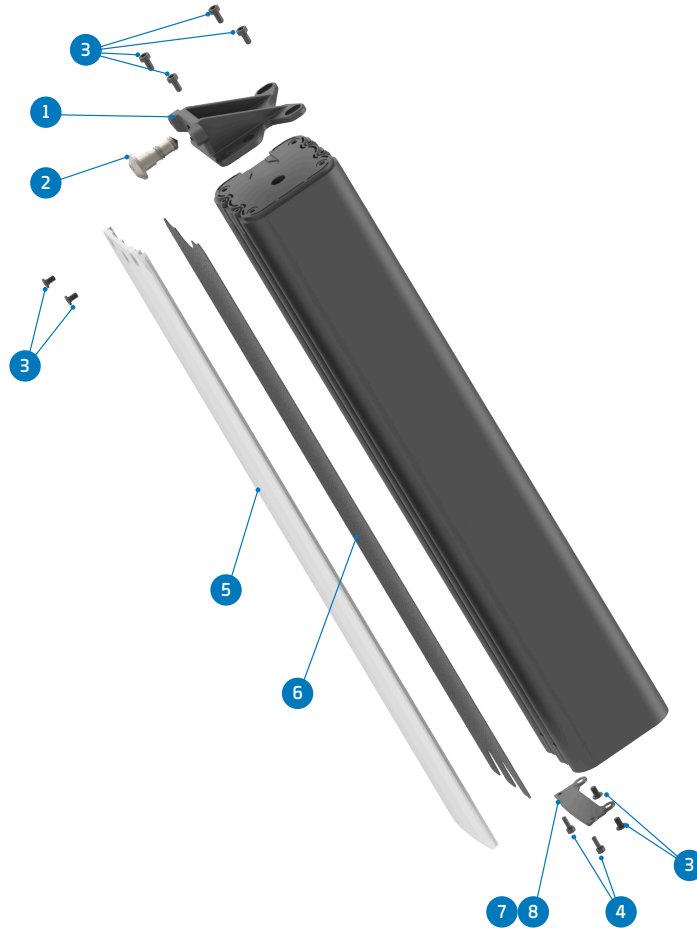

ITEM	DESCRIPTION	QTY.	PART NUMBER
1	BATTERY MOUNT BRACKET FRONT	1	099.25049
2	BATTERY RELEASE SCREW	1	099.25051
3	SCREW BOLT M4X6	8	099.25052
4	SCREW BOLT M4X8	2	099.12116
5	BATTERY COVER	1	Refer to B2B web for color options
6	FOAM FOR BATTERY COVER	1	099.25089
Choose between:			
7	BATTERY HOLDER REAR 800Wh (only for 800Wh battery)	1	099.26020
8	BATTERY HOLDER REAR 600Wh (only for 600Wh battery)	1	099.26021
9	FOAM FOR 600Wh BATTERY (only 600wh battery)	1	099.25097



HINTERE
BATTERIEHALTERUNG
800Wh
Ref. 099.26020

HINTERE
BATTERIEHALTERUNG
600Wh
Ref. 099.26021



9. SCHAUMSTOFFPLATTEN

9.1. SCHAUMSTOFFPLATTEN FÜR DEN FAHRRADRAHMEN

Ref. 099.25088



10. BOSCH SYSTEM CONTROLLER KIOX 400

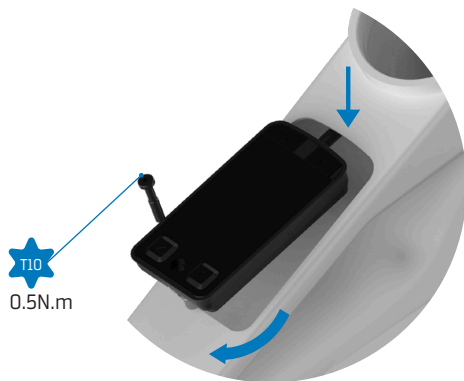

11. BOSCH MINI REMOTE

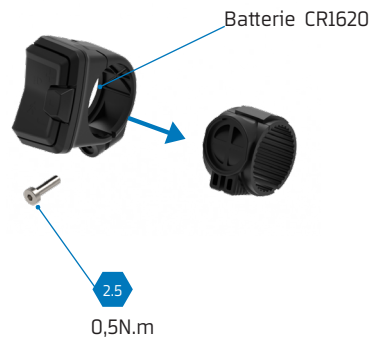

12. CHAINSTAY PROTECTOR



Kettenstrebenschutz ohne Loch für mechanische oder kabelgebundene Schaltungen. Auf der Rückseite befindet sich eine Markierung zum Durchstechen des Kabelausgangs.

Für ein optimales Ergebnis wird die Verwendung einer Lochzange empfohlen.



13. RANGE EXTENDER BOSCH POWERMORE KIT

EU28, CH, NO, AUS, NZ

POWERMORE 250 KIT (BBP3620 EU28,CH,NO,AUS,NZ)
incl. battery holder, bottle holder, screws, IBD packaging
EB12.100.05G

US, CANADA

POWERMORE 250 KIT (BBP3625 US, CAN) incl.
battery holder, bottle holder, screws, IBD packaging
EB12.100.05H



CABLE POWERMORE 150MM (BCH3923_150) **EB12.120.036**



14. SPRITZSCHUTZ

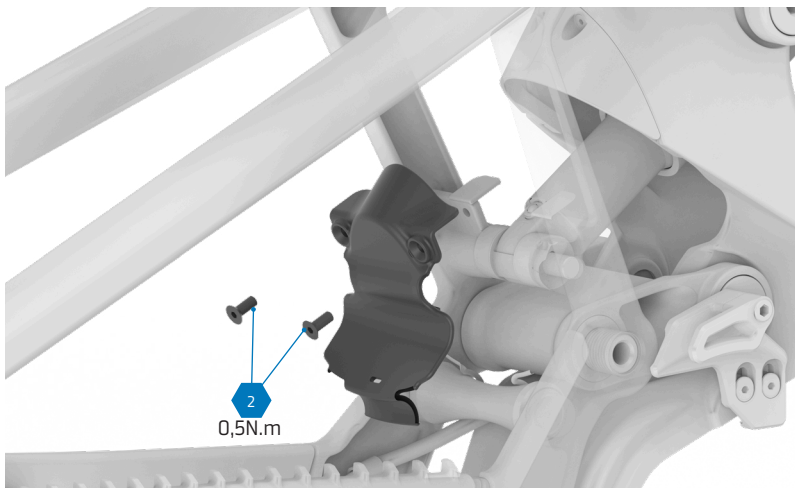
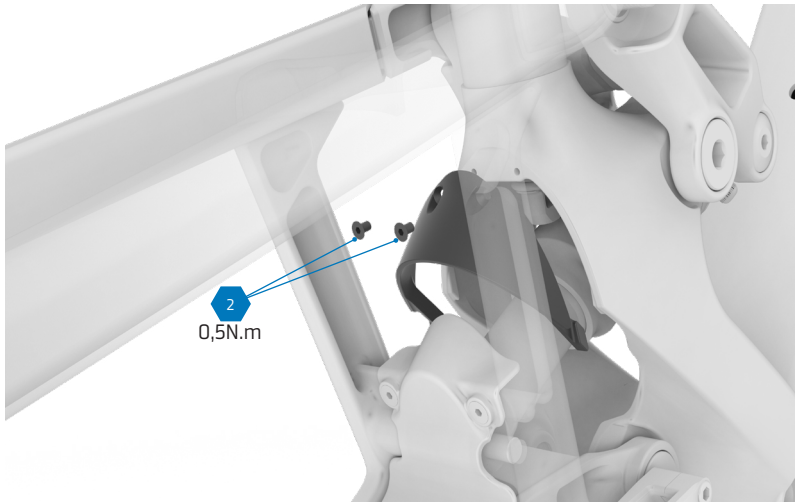

15. SATTELSTÜTZENKLEMME

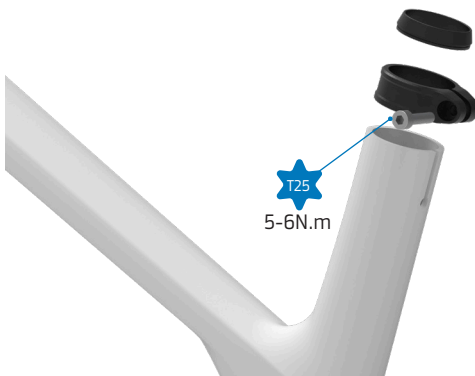

Es wird empfohlen
zwischen Rahmen und
Sattelstütze spezielle
Carbon-Montagepaste
aufzutragen



16. MONTAGEANLEITUNG FÜR OBERE WIPPE

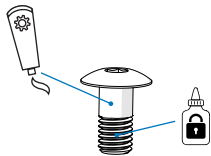
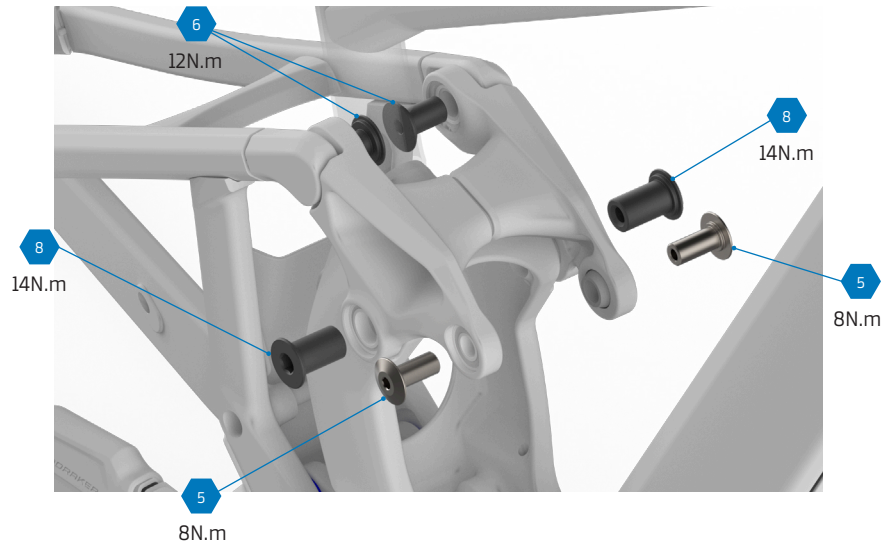

Tragen Sie auf den Schaft der Hauptschrauben Fett auf und auf das Gewinde Loctite 243 oder Ähnliches

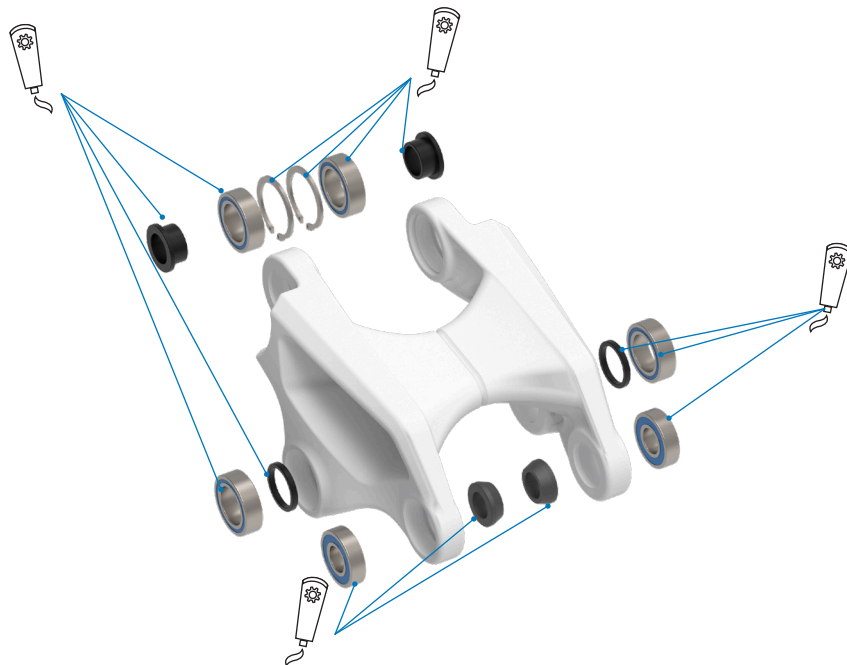

Fett auftragen.



17. MONTAGEANLEITUNG FÜR UNTERE WIPPE

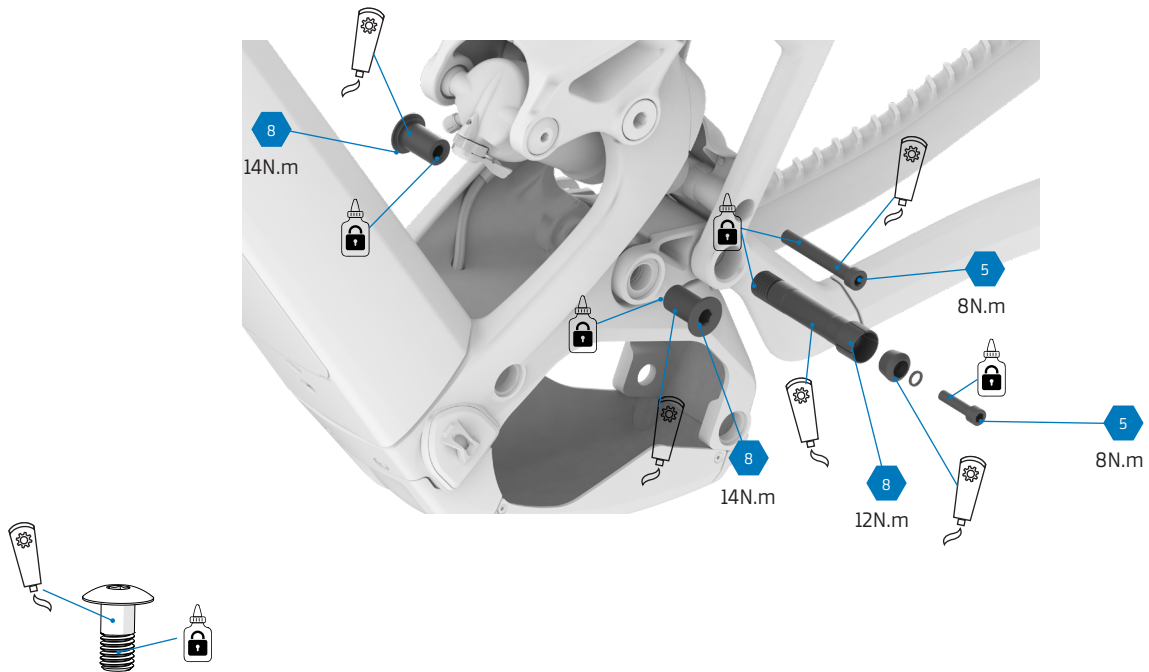

Tragen Sie auf den Schaft der Hauptschrauben Fett auf und auf das Gewinde Loctite 243 oder Ähnliches.

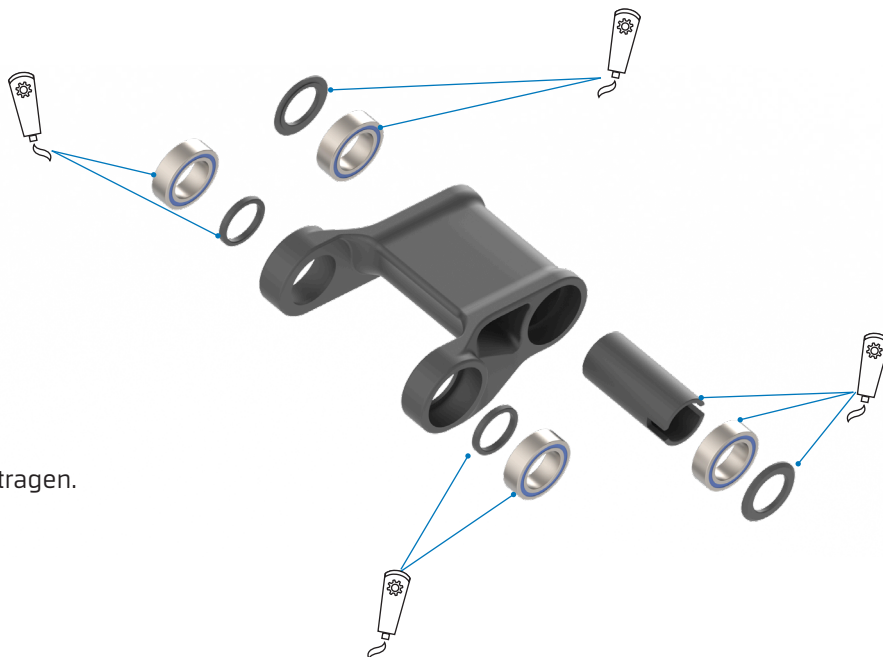



19. KOPPELN DES SMARTPHONES



eBike Flow app



Schalten Sie Ihr Fahrrad ein.
Drücken Sie nach dem Einschalten 5 Sekunden lang die Power-Taste bis eine blaue LED zu blinken beginnt.
Öffnen Sie dann die eBike Flow App und befolgen Sie die Anweisungen auf Ihrem Telefon, um sich zu verbinden



20. MONTAGE DES VORBAUS

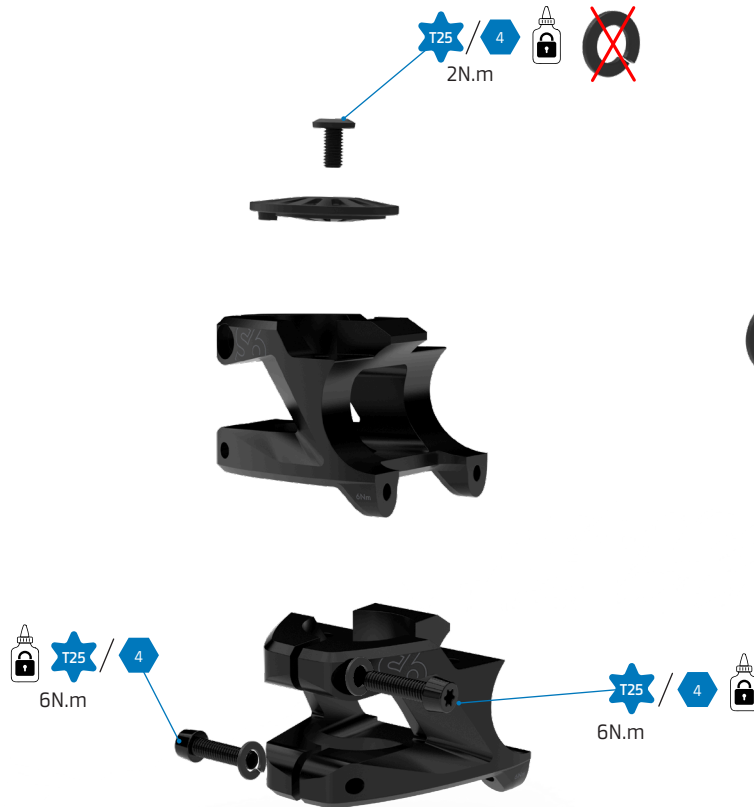

Die 6 Schrauben des Vorbaus, mit Ausnahme der Schraube für die Steuersatzkappe, müssen mit einem Federring versehen sein.

1. Einsetzen des Vorbaus

Schieben Sie den Vorbaukörper auf den Gabelschaft, bis er richtig sitzt.

2. Einstellung des Steuersatzes (Vorspannung)

Setzen Sie die Steuersatzkappe (Top Cap) und die dazugehörige Schraube ein. Ziehen Sie die obere Schraube mit einem maximalen Drehmoment von 1 Nm an, um die Lager vorzuspannen und jegliches Spiel in der Lenkung zu beseitigen.

3. Anziehen der seitlichen Klemmschrauben

Richten Sie den Vorbau am Vorderrad aus. Ziehen Sie die seitlichen Klemmschrauben schrittweise und abwechselnd an, um die Last zu verteilen. Erhöhen Sie die Spannung allmählich (z. B. oben 4 Nm, unten 4 Nm, dann beide 5 Nm), bis beide Schrauben das exakte finale Anzugsdrehmoment von 6 Nm erreichen.

Montagetipp:

Der Vorbau lässt sich optisch leichter am Vorderrad ausrichten, wenn der Lenker bereits montiert ist. Führen Sie diesen Schritt daher zunächst nur mit einer leichten Spannung der seitlichen Schrauben durch, gehen Sie dann zur Montage des Lenkers (Abschnitt 2) über, nehmen Sie die endgültige Ausrichtung der gesamten Einheit vor und ziehen Sie erst danach die seitlichen Klemmschrauben am Gabelschaft mit dem endgültigen Drehmoment von 6 Nm fest.



21. MONTAGE DES LENKERS

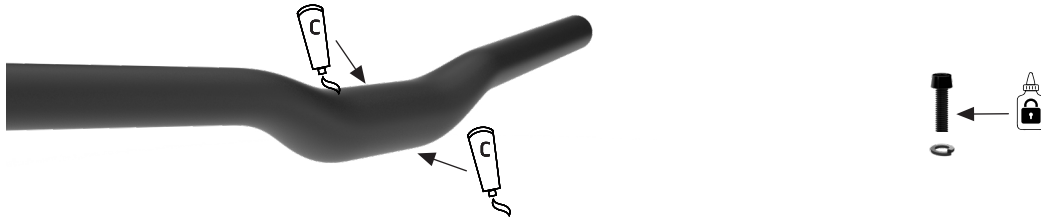

Tragen Sie eine dünne Schicht Carbon-Montagepaste auf die Kontaktfläche zwischen Lenker und Vorbau auf. Wenn die Schraubengewinde trocken sind, geben Sie jeweils einen kleinen Tropfen LOCTITE 243.

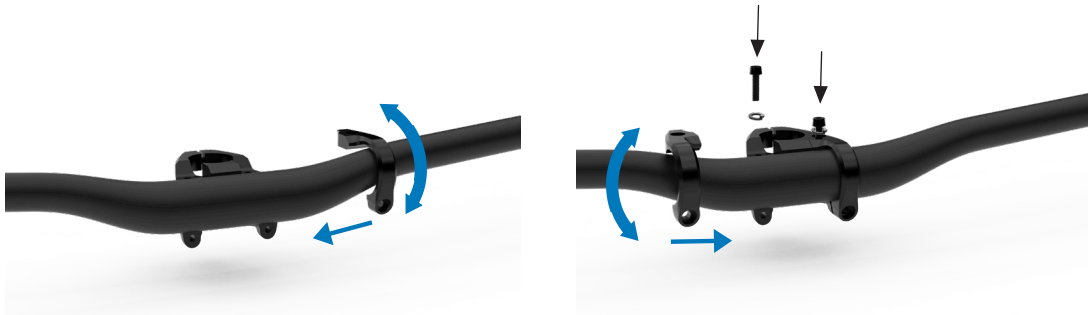

Tragen Sie eine dünne Schicht Carbon-Montagepaste auf die Kontaktfläche zwischen Lenker und Vorbau auf. Wenn die Schraubengewinde trocken sind, geben Sie jeweils einen kleinen Tropfen Montagefett darauf. Wichtig: Mischen Sie keine verschiedenen Fettsorten.

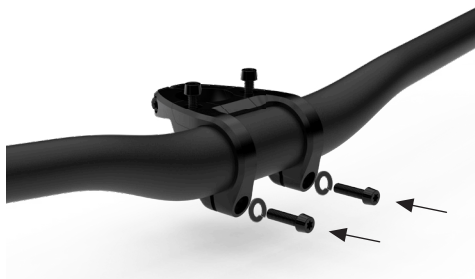

Setzen Sie die beiden oberen Schrauben ein und drehen Sie sie von Hand einige Umdrehungen ein, ohne das endgültige Anzugsmoment anzuwenden. Führen Sie anschließend die beiden unteren Schrauben ein, ohne sie festzuziehen.

Hinweis: Wenn es schwierig ist, die unteren Schrauben auszurichten oder einzuschrauben, lösen Sie die oberen Schrauben leicht, um das Einsetzen zu erleichtern, und versuchen Sie es erneut.



21. MONTAGE DES LENKERS

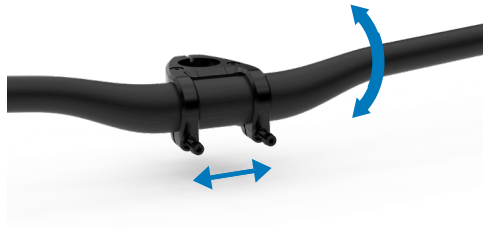

Passen Sie die Drehung und Zentrierung des Lenkers an, bis die gewünschte Position erreicht ist.

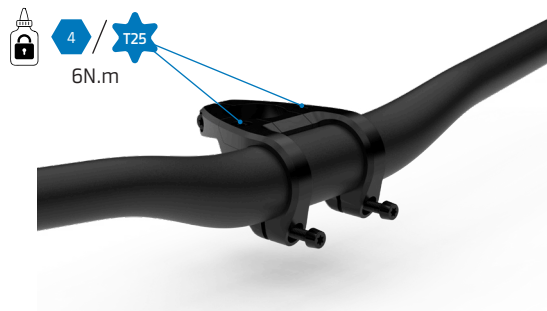

Ziehen Sie die oberen Schrauben schrittweise und abwechselnd auf beiden Seiten an. Erhöhen Sie die Spannung allmählich (z. B. 4 Nm, dann 5 Nm auf jeder Seite), bis das exakte finale Anzugsdrehmoment von 6 Nm erreicht ist. Es ist von entscheidender Bedeutung, dass in diesem Schritt beide oberen Schrauben vollständig mit 6 Nm angezogen werden.

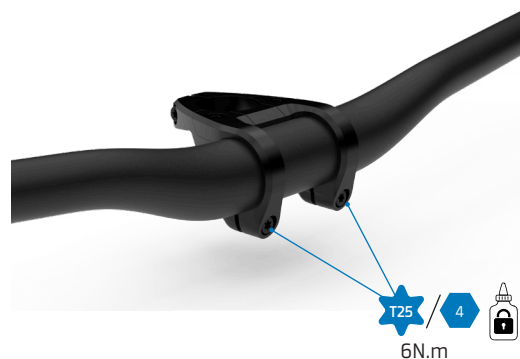

Bringen Sie den Lenker in seine endgültige Position und ziehen Sie die unteren Schrauben schrittweise und abwechselnd auf der linken und rechten Seite an (4 Nm, 5 Nm und schließlich 6 Nm), um die Last gleichmäßig zu verteilen.

Überprüfen Sie visuell den korrekten Sitz des Vorbaus. Konstruktionsbedingt darf an der Oberseite kein Spalt zwischen den Bauteilen vorhanden sein; der Klemmspalt darf sich ausschließlich an der Unterseite befinden. Überprüfen Sie abschließend mit dem Drehmomentschlüssel, ob alle vier Schrauben das vorgegebene Drehmoment von 6 Nm aufweisen. Wischen Sie überschüssiges Fett ab.



22. SPARE PARTS
SCREE

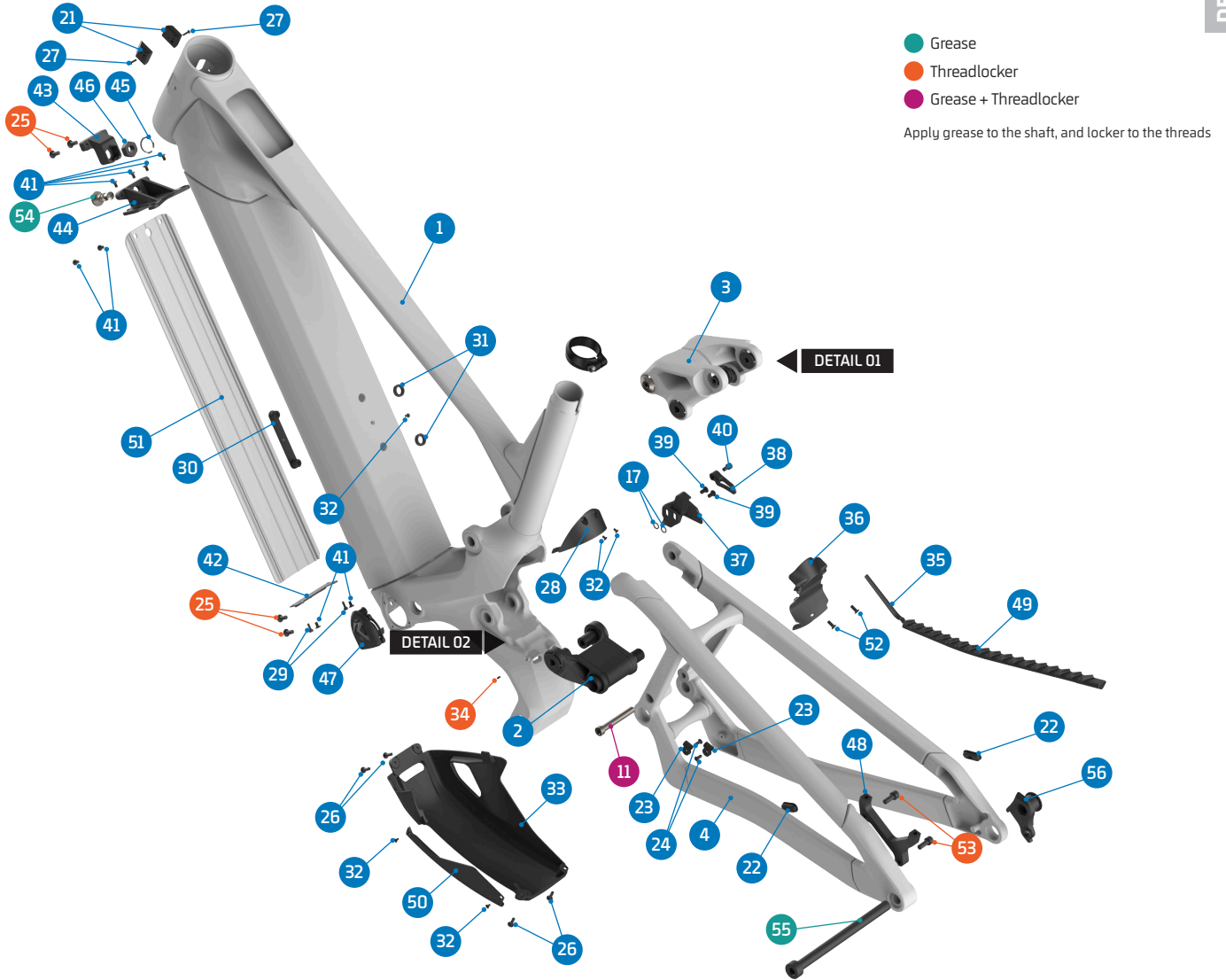

ITEM No.	DESCRIPTION	QTY.	PART NUMBER	TORQUE
1	FRONT TRIANGLE	1		
2	SCREE LOWER LINK	1	099.26009	
3	SCREE UPPER LINK	1	Refer to B2B web for color options	
4	SCREE REAR TRIANGLE	1		
5	BEARING, 24X15X7 (3802-2RS)	8	SET 1	
6	BEARING, 10x22x6 (6900V-2RS)	2	SET 1	
7	C-RING	2	SET 3	
8	MAIN AXLE	1	SET 4	12Nm
9	UPPER LINK-RT SPACER	2	SET 3	
10	PIVOT AXLE, M12	2	SET 3	12Nm
11	SHOCK BOLT	1	SET 2 / 099.24022	8Nm
12	SPACER	1	SET 4	
13	SPACER, 15x27x2	2	SET 4	
14	SPACER, 10x17x6	2	SET 2	
15	SPACER, 15x19x2.5t	4	SET 3 / 4	
16	TAPER NUT	1	SET 4	
17	SPACER	3	SET 4 / 5	
18	SCREW BOLT, M6x25	1	SET 4	8Nm
19	PIVOT AXLE, M15	4	SET 3 / 4	14Nm
20	SHOCK BOLT	2	SET 2	8Nm
21	CABLE GUIDE	2	SET 7	
22	CABLE RUBBER	2	989.13010	
23	SINGLE CABLE GUIDE	2	099.22064	
24	SCREW BOLT, M4x8	2		1Nm
25	SCREW BOLT, M5x12	4	099.12141	4,5Nm
26	SCREW BOLT, M4x12	4	099.20078	
27	SCREW BOLT, M3x10	2	SET 7	1Nm
28	SCREE FRONT TRIANGLE FENDER	1	099.26016	
29	SCREW BOLT, M3x8	2	099.12116	2Nm

ITEM No.	DESCRIPTION	QTY.	PART NUMBER	TORQUE
30	BOTTLE CAGE STAND	1	099.25072	
31	BOTTLE CAGE STAND SPACERS	2	099.25074	
32	SCREW BOLT, M3x5	5	099.25028	2Nm
33	MOTOR COVER	1	099.26017	
34	SCREW BOLT, M3x5	1		1Nm
35	CHAINSTAY PROTECTOR YOKE	1	099.26018	
36	REAR TRIANGLE FENDER	1	099.26019	
37	CHAIN GUIDE, BASE	1	SET 5	
38	CHAIN GUIDE, OUTER	1	SET 5	
39	SCREW BOLT, M5x12	2	SET 5	2Nm
40	SCREW BOLT, M5x8	1	SET 5	2Nm
41	SCREW BOLT, M4x6	8	099.25052	1,5Nm
42	COVER BRACKET 800WH	1	099.26020	
	COVER BRACKET 600WH	1	099.26021	
43	BATTERY MOUNT	1	099.25082	
44	BATTERY MOUNT BRACKET	1	099.25049	
45	C-RING	1	099.25083	
46	NUT	1	099.25084	
47	CHARGE PLUG SET	1	099.24064	
48	DISC MOUNT	1	SET 6	
49	CHAINSTAY PROTECTOR	1	099.26022	
50	SKID PLATE LEFT SIDE COVER	1	099.26023	
51	BATTERY COVER	1	Refer to B2B web for color options	
52	SCREW BOLT, M4x10	2		1 Nm
53	SCREW BOLT, M6x15	2	SET 6	12Nm
54	BATTERY RELEASE SCREW	1	099.25051	12Nm
55	REAR AXLE	1	112.90027	
56	HANGER	1	SRAM UDH	



DETAIL 01

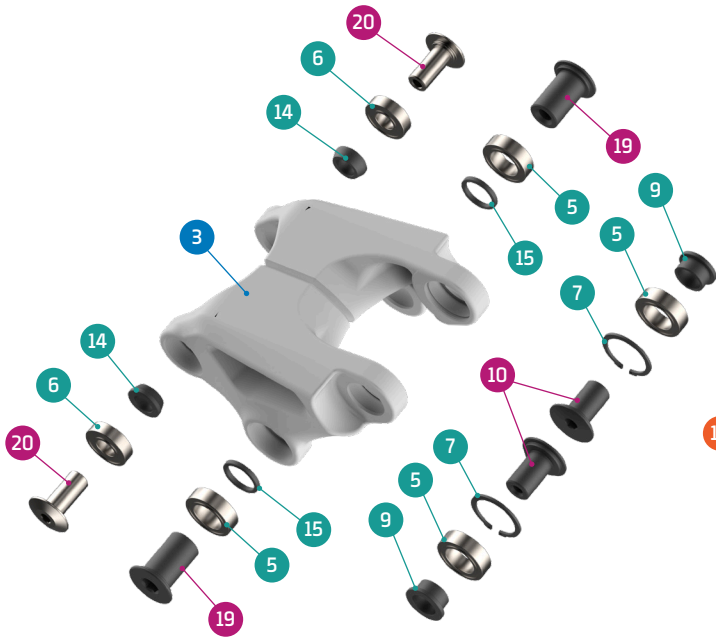

DETAIL 02

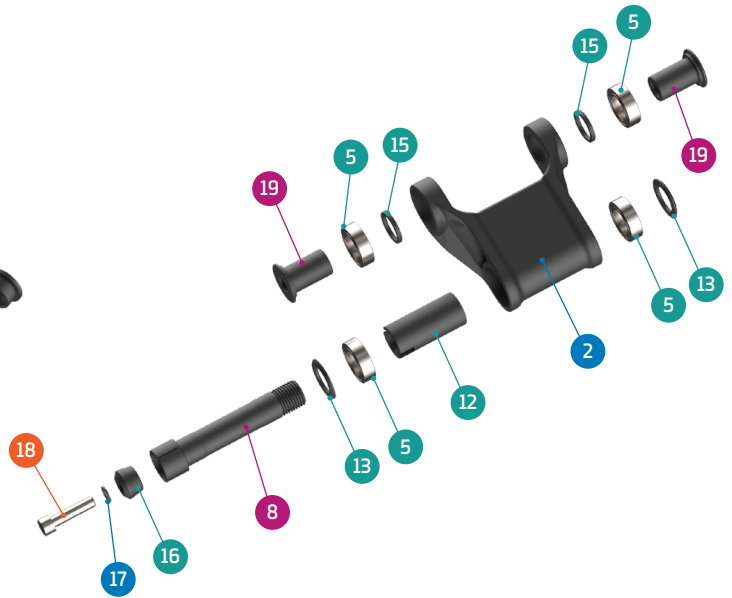

FOAM FOR BATTERY (600WH)

FOAM FOR MAIN TUBE

FOAM FOR BATTERY COVER

SET 7

SET 6

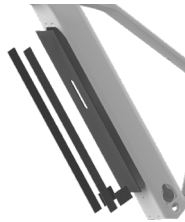

CABLE GUIDE KIT

DISC ADAPTOR KIT

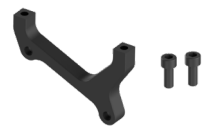

SET 1

SET 2

SET 3

SET 4

SET 5

ZERO BEARING KIT 26

SHOCK HARDWARE KIT 22

UPPER LINK KIT 30

LOWER LINK KIT 37

CHAIN GUIDE PLATE + BOLTS

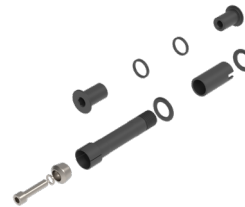

PART NUMBER	DESCRIPTION	COMPONENTS
099.22101	SET 1: ZERO BEARING KIT 26	BEARING 3802-2RS, 24x15x7 (x8) / BEARING 6900V-2RS, 10x22x6 (x2)
099.24200	SET 2: SHOCK HARDWARE KIT 22	SPACER (x2) / SHOCK BOLT (x2) / SHOCK BOLT (x1)
099.22300	SET 3: UPPER LINK KIT 30	SPACER, 15x19x2.5T (x2) / UPPER LINK-RT SPACER (x2) / PIVOT AXLE, M12 (x2) / PIVOT AXLE, M15 (x2) / C-RING (x6)
099.25400	SET 4: LOWER LINK KIT 37	SPACER, 15x27x2 (x2) / SPACER, 15x19x2.5t (x2) / INNER LOWER LINK SPACER (x1) / PIVOT AXLE, M10 (x1) / AXLE NUT, M10 (x1) / MAIN AXLE (x1) / SPACER (x1) / TAPER NUT (x1) / SCREW BOLT (x1)
099.24018	SET 5: CHAIN GUIDE PLATE + BOLTS	CHAIN GUIDE BASE (x1) / CHAIN GUIDE OUTER PLATE (x1) / SCREW BOLT, M5x12 (x2) / SCREW BOLT, M5x8 (x1) / WASHER 5x9x1t (x4)
099.25018	SET 6: DISC ADAPTOR KIT	DISC ADAPTOR (x1) / SCREW BOLT (x2)
099.25013	SET 7: CABLE GUIDE KIT	CABLE GUIDE (x1) / SCREW BOTL M2.5X5L (x1) / SCREW BOLT M3X10L (x1)
099.25088	FOAM KIT FOR MAIN TUBE	
099.25089	FOAM FOR BATTERY COVER	
099.25097	FOAM FOR 600Wh BATTERY	



23. FAQs

WORIN BESTEHT DER UNTERSCHIED ZWISCHEN DEM NEUEN SCREE UND DEM CRAFTY CARBON?

Sowohl das Scree als auch das Crafty Carbon gehören zu Mondrakers vielseitigsten E-MTBs, verfolgen jedoch unterschiedliche Einsatzschwerpunkte. Rahmen, Kinematik, Geometrie und Federweg unterscheiden sich jeweils zwischen beiden Modellen. Scree ist ein vollständig neues, konsequent auf den Trail-Einsatz ausgelegtes Modell mit 130 mm Hinterrad- und 150 mm Vorderradfederweg in einem Stealth-Aluminiumrahmen, während Crafty Carbon ein Enduro-Modell mit längerem Federweg von 150 mm hinten und 160 mm vorne ist und über einen Stealth-Air-Carbonrahmen verfügt. Beide Modelle verwenden den neuesten Bosch Performance CX Gen 5 Motor sowie 600-Wh- oder 800-Wh-Akkus. Beide Baureihen sind in fünf Größen mit jeweils spezifischer Geometrie erhältlich. Beide sind mit der neuesten Generation des Bosch Performance CX Motors mit bis zu 100 Nm und 750 W ausgestattet und mit den 800-Wh- und 600-Wh-Batterien kompatibel – für ein optimales Fahrerlebnis.

WIE VIEL WIEGT DER RAHMEN DES NEUEN SCREE?

Der lackierte Scree-Rahmen, komplett mit Hardware und Zubehör, jedoch ohne Dämpfer, wiegt in Größe ML rund 4,90 kg.

WIE VIEL LEICHTER IST DER 600WH-AKKU IM VERGLEICH ZUM 800WH-AKKU?

Die Powertube 800Wh wiegt 3.990 Gramm und die neue Powertube 600Wh wiegt 3.070 Gramm; beide nutzen Akkuzellen der neuesten Generation im 21700-Format.

WELCHE DÄMPFER SIND MIT DEM NEUEN SCREE KOMPATIBEL?

Scree ist mit allen Inline-Dämpfern kompatibel und seine Kinematik wurde dafür optimiert, mit Inline-Dämpfern gefahren zu werden. Es können auch Piggyback-Modelle wie die Float-X-Serie oder der RockShox SuperDeluxe verwendet werden. Bei allen Dämpfern mit größerem Volumen ist eine vorherige Prüfung zwingend erforderlich, da es möglicherweise nicht passt. Scree verwendet metrische Dämpfer im Maß 165x45 mm mit Trunion-Aufnahme oben und 30x8-mm-Standardhardware unten.

WELCHE KINEMATISCHEN EIGENSCHAFTEN BIETET DAS KOMPLETT NEUE SCREE?

Das Zero-Suspension-Design und -Layout wurde aktualisiert und verbessert, basierend auf den neuesten Performance-Entwicklungen der neuesten Generation der vollgefederten Mondraker-Bikes – in diesem Fall speziell abgestimmt auf den vielseitigen Trail-Einsatz. Scree verfügt über eine Progressionsrate von 20,5 %, ein höheres Übersetzungsverhältnis für ein geschmeidigeres und sensibleres Ansprechen im Anfangsbereich sowie etwas niedrigere Anti-Squat- und Anti-Rise-Kurven für ein leistungsfähigeres und insgesamt effizienter arbeitendes Hinterradfahrwerk.

WIE GROSS IST DER MAXIMALE FEDERWEG DER GABEL DES NEUEN SCREE?

Scree ist mit Gabeln bis zu 160 mm Federweg bzw. einem Achse-zu-Krone-Maß von 580 mm kompatibel.

IST ES MÖGLICH, AM SCREE EINE GRÖßERE 220-MM-HINTERRADBREMSSCHEIBE ZU VERWENDEN?

Ja, Scree ist mit größeren hinteren Bremscheiben von 220 mm kompatibel. Wir empfehlen es zwar nicht, aber es ist möglich, diese an den Crafty-Carbon-Modellen zu verbauen.

WIE GROSS IST DIE MAXIMALE REIFENBREITE, DIE AM SCREE MONTIERT WERDEN KANN?

Scree ist mit Reifen bis zu 66 mm Breite kompatibel, was 29"×2,6"-Reifen entspricht. Es wird empfohlen, den Reifen vor der Montage auszumessen, da die tatsächliche Breite je nach Hersteller variieren kann.



23. FAQs

IST DAS SCREE MIT EINEM 27,5"-HINTERRAD KOMPATIBEL?

Technisch wäre es möglich, ein kleineres 27,5"-Hinterrad zu fahren, allerdings wurde das Bike nicht für einen Mullet-Aufbau konzipiert und der Motor würde nicht optimal arbeiten, da sich dadurch der Raddurchmesser verändert. Der geringere Radumfang beeinträchtigt die Genauigkeit der Geschwindigkeitsmessung und kann nicht angepasst werden. Eine 27,5×2,6"-Kombination reduziert beispielsweise die Abregelgeschwindigkeit um etwa 1 bis 2 km/h. Zudem besteht die Möglichkeit, dass der Motorsensor mit dem Magneten am kleineren Hinterrad nicht korrekt funktioniert. Die Geometrie des Scree würde ebenfalls beeinträchtigt werden, mit um etwa –1,5° veränderten Winkeln und einer Tretlagerabsenkung von –13 bis –15 mm. Wichtiger noch: Mondraker gewährt keine Garantie, wenn ein anderes Hinterrad als das serienmäßige 29"-Rad gefahren wird.

WÄRE ES MÖGLICH, EINEN BATTERIE-EXTENDER HINZUZUFÜGEN, UM DIE REICHWEITE ZU ERHÖHEN UND LÄNGER FAHREN ZU KÖNNEN?

Ja, wie bei allen aktuellen Bosch-Motorsystemen gibt es einen Bosch Powermore 250Wh Range Extender im „Trinkflaschenhalter“-Stil. Er wiegt 1.450 Gramm bzw. 1.525 Gramm einschließlich der seitenspezifischen Bosch-Montagehalterung und des Verbindungskabels. Damit ergibt sich eine deutlich höhere Reichweite im Vergleich zu den internen Powertube-Akkus mit 600Wh (+40 %) bzw. 800Wh (+30 %).

WELCHE WICHTIGEN PUNKTE SIND BEIM VERBAU EINER POWERMORE-EINHEIT ZU BEACHTEN?

Bosch bietet verschiedene Längen des Verbindungskabels für den Powermore-Range-Extender an; für alle Scree-Modelle wird die 150-mm-Variante benötigt. Die Bosch-Teilenummer lautet BCH3923_150 / EB12.120.036. Zudem ist zu beachten, dass zwei Powermore-Versionen existieren, die je nach Region unterschiedlich sind: PowerMore EU28, CH, NO, AUS, NZ (BBP3620 / EB12.100.05G) sowie PowerMore US, CAN, KOR (BBP3625 / EB12.100.05H).

KANN EINE TRINKFLASCHE MONTIERT WERDEN?

Ja. Es stehen zwei Positionen für einen Flaschenhalter zur Verfügung: im Hauptdreieck an der üblichen Standardposition sowie unterhalb des Oberrohrs.

DIE KABELFÜHRUNG ERFOLGT AUSSEN AM STEUERROHR – IST EINE INTERNE FÜHRUNG DURCH DEN STEUERSATZ MÖGLICH?

Ja, das ist möglich. Die neue obere Steuersatzschale ist für eine interne Kabelführung vorbereitet und ermöglicht auf Wunsch eine vollständig integrierte Leitungsführung.

IST ES MÖGLICH, DEN INTERNEN AKKU AUSZUBAUEN?

Ja. Beim neuen Scree lässt sich der interne Akku einfach entnehmen. Dazu wird lediglich die obere 5-mm-Inbusschraube an der Unterseite des Hauptrohrs gelöst, woraufhin der Akku entnommen werden kann – zum externen Laden, zum Austausch oder für Wartungsarbeiten.

GIBT ES ZWEI AKKUGRÖSSEN, 800WH UND 600WH, UND KÖNNEN BEIDE IM SCREE VERWENDET WERDEN?

Ja. Alle Scree-Modelle erlauben die Verwendung sowohl des Powertube-800Wh- als auch des 600Wh-



23. FAQs

Akkus. Wird das Fahrrad mit einer der beiden Varianten ausgeliefert, kann ein zusätzlicher Akku erworben und bei Bedarf eingesetzt werden. Dazu sind die passenden Adapter erforderlich (600-Wh-Akkus benötigen andere Adapter als 800-Wh-Modelle, da sich die Bauhöhen unterscheiden). Eine zusätzliche Akkuabdeckung kann über Mondraker bezogen werden, um zwei vollständig austauschbare Akkus einsatzbereit zu halten. Technisch ist es möglich, die vorhandene Abdeckung vom serienmäßigen Akku zu demontieren und auf einen weiteren Akku zu montieren; allerdings unterscheidet sich der innenliegende Schaumstoff ebenfalls zwischen beiden Akkuvarianten. Ältere und schwerere 750Wh- und 625Wh-Akkus könnten technisch kompatibel sein, jedoch stellt Mondraker keine entsprechenden Adapter für diese Rahmen bereit. Der Betrieb allein mit dem Powermore-Range-Extender ohne internen Akku wäre zwar möglich, Bosch rät jedoch ausdrücklich davon ab, und das Fahrrad ist nicht dafür vorgesehen, ausschließlich mit dem Range Extender betrieben zu werden.

WIE LANGE DAUERT ES, DEN AKKU VOLLSTÄNDIG AUFZULADEN?

Die Powertube-800Wh-Batterie benötigt für eine vollständige Ladung etwa 6 Stunden, die 600Wh-Version rund 4,5 Stunden, sofern sie vollständig entladen ist. Ein PowerMore-Range-Extender muss separat geladen werden; eine vollständige Ladung dauert etwa 2,5 Stunden.

GIBT ES BESONDERE HINWEISE ODER ANWEISUNGEN FÜR DEN AKKU?

Es sind keine besonderen Hinweise erforderlich. Der verbleibende Akkustand wird über das Kiox-400c-Display am Oberrohr angezeigt. Ab ca. 30 % Restkapazität reduziert das System die Motorunterstützung leicht; bei etwa 10 % wird diese Reduktion deutlicher spürbar. Weitere besondere Vorgaben bestehen nicht.

KÖNNEN SRAM-SCHALTKÄFIGE DER NEUESTEN T-TYPE-GENERATION DIREKT ÜBER DIE HAUPTBATTERIE DES FAHRRADS BETRIEBEN WERDEN, IST DAS BEI DEN SCREE-MODELLEN MÖGLICH?

Ja, technisch ist das möglich. Dazu müssen die entsprechenden Zubehörteile erworben und das Ladekabel intern bis zur Hauptbatterie verlegt werden.

MEIN SCREE VERFÜGT ÜBER EINE SRAM-T-TYPE-SCHALTGRUPPE, IST ES MÖGLICH, EINE SHIMANO-SCHALTGRUPPE MIT SCHALTWERK ZU VERWENDEN?

Ja, problemlos. Es wird lediglich ein zusätzlicher UDH-Schaltaugenadapter für das Shimano-Schaltwerk benötigt.

WIE HOCH IST DIE MAXIMALE UNTERSTÜTZUNG, DIE DER BOSCH PERFORMANCE CX MOTOR DES SCREE LEISTEN KANN?

Der serienmäßige Bosch Performance CX Motor (BDU384Y) liefert 85 Nm Drehmoment und 600 W Spitzenleistung. Über die Bosch Flow App kann die Motorleistung auf bis zu 100 Nm und 750 W Spitzenleistung erhöht werden.

IST ES MÖGLICH, DIE UNTERSTÜTZUNGSMODI DES SCREE INDIVIDUELL ANZUPASSEN?

Ja. Die Unterstützungsmodi des Bosch Performance CX Motors können – wie bei allen Bosch-Antriebssystemen – über die Flow App individuell konfiguriert werden. Hierzu die Flow App öffnen, sich anmelden, das Fahrrad einschalten und die Verbindung zum Scree herstellen. Anschließend lassen sich Parameter wie Unterstützungsgrad, Anfahrverhalten (Dynamic), maximale Unterstützungs-geschwindigkeit (25 km/h bzw. 20 mph) sowie das maximale Drehmoment von 100 Nm für die vier Modi ECO, TOUR+, EMTB+ und TURBO jeweils separat anpassen. Zudem besteht die Möglichkeit, die Anzahl der verfügbaren Modi zu reduzieren und das Bike mit weniger als vier Unterstützungsstufen zu betreiben.

WIE LANGE KANN ICH MIT DEM NEUEN SCREE FAHREN?

Diese Frage ist nicht leicht zu beantworten, denn die Reichweite hängt stark vom gewählten



23. FAQs

Unterstützungsmodus, der Fitness des Fahrers, dem Fahrergewicht und den jeweiligen Streckenbedingungen ab. Mit dem neuen PT800-Wh-Akku kann ein durchschnittlicher Fahrer mit einem Systemgewicht von 80 kg rund 2.000 Höhenmeter bewältigen (ca. 1.500 m mit dem PT600-Wh-Akku), wenn er verschiedene Unterstützungsstufen kombiniert. In den Modi ECO bis TOUR+ sind damit bis zu etwa 4 Stunden Fahrzeit möglich – abhängig von Gelände und körperlicher Leistungsfähigkeit. Der 250-Wh-PowerMore-Range-Extender verlängert die Fahrzeit bzw. Distanz um +30 % (in Kombination mit dem PT800-Wh-Akku) bzw. +40 % (mit dem PT600-Wh-Akku) – bei lediglich 1,5 kg zusätzlichem Gewicht.

WENN ICH MIT DEM POWERMORE-RANGE-EXTENDER FAHRE – WELCHER AKKU WIRD ZUERST ENTLEERT: DER INTERNE ODER DER EXTENDER?

Um eine gleichbleibende Motorleistung zu gewährleisten, werden beide Akkus parallel entladen. Das ist entscheidend für eine optimale Akkulebensdauer und eine konstante Unterstützungsleistung des Motors. Wird der PowerMore erst zugeschaltet, wenn der interne Akku bereits fast leer ist, dient er zunächst als Hauptenergiequelle, bis sich die Ladestände beider Akkus angeglichen haben. Anschließend werden beide Akkus gleichmäßig weiterentladen, bis sie vollständig erschöpft sind.

WELCHE INFORMATIONEN BIETET DAS SCREE DISPLAY?

Alle Informationen zur Bedienung des Displays sowie der Remote-Einheit finden Sie unter folgendem Link von BOSCH: <https://www.bosch-ebike.com/en/products/kiox-400c>

ICH MÖCHTE MEHR DETAILS ÜBER DEN BOSCH-BDU384Y-PERFORMANCE-CX-MOTOR ERFAHREN. WO FINDE ICH WEITERE INFORMATIONEN?

Ausführliche Informationen stellt BOSCH unter diesen Links bereit:

<https://www.bosch-ebike.com/en/products/performance-line-cx> und <https://www.boschebike.com/en/products/performance-line-cx-r>

WELCHE WARTUNG ODER SICHERHEITSPRÜFUNGEN SIND BEIM BOSCH PERFORMANCE CX MOTOR ERFORDERLICH?

Keine. Weder müssen Teile der Antriebseinheit geschmiert noch demontiert werden – Sie pflegen das System im Grunde wie ein herkömmliches Mountainbike. Wichtig ist jedoch ein allgemeiner Hinweis, der für jedes Mountainbike gilt: Elektronische Komponenten und insbesondere der Tretlagerbereich der Antriebseinheit dürfen nicht mit einem Hochdruckreiniger gereinigt werden. Es wird ausdrücklich davon abgeraten, den Kurbel- bzw. Achsbereich mit einem starken Wasserstrahl zu säubern, da die elektronischen Bauteile der Antriebseinheit dadurch ernsthaft beschädigt werden können.

WELCHE RAHMENGRÖSSE BENÖTIGE ICH?

Das neue Scree 2026 setzt auf ein aktualisiertes Größensystem mit fünf Rahmengrößen, einschließlich der neuen Zwischengröße ML zwischen Medium und Large. Im Unterschied zu den üblichen vier Größen vieler anderer Modelle ermöglicht dieses Konzept eine noch passgenauere Abstimmung auf unterschiedliche Fahrerprofile. Weitere Informationen und alle Details finden Sie in den Geometrietabellen. Nachfolgend erhalten Sie einen Überblick über die empfohlenen Größen in Abhängigkeit von der Körpergröße.

<165 cm	165-170 cm	170-175 cm	175-180 cm	180-185 cm	185-190 cm	190-195 cm	>195 cm
S		M/L			XL		
M			L				



Alle Informationen und Bilder in diesem Dokument dienen nur zu Informationszwecken und stellen keinen rechtlichen Vertrag zwischen Mondraker und einer natürlichen oder juristischen Person dar. Spezifikationen, Geometrien und andere veröffentlichte technische Informationen können ohne vorherige Ankündigung geändert werden.

© © Alle Marken und Modelle sind Eigentum von Blue Factory Team, S.L.U. und durch geltende Gesetze und anwendbare internationale Übereinkommen geschützt.

MANUELS ET DOCUMENTS



CONSIGNES GÉNÉRALES ET DE SÉCURITÉ

Les 3 icônes suivantes peuvent apparaître dans ce guide technique. Chacune d'elles indique que les précautions indiquées doivent être prises :

AVERTISSEMENT :

Le non-respect des instructions ou une utilisation inappropriée du vélo peuvent causer des blessures graves, voire entraîner la mort. Ces opérations impliquent des difficultés techniques et, si elles ne sont pas effectuées correctement, elles pourraient endommager votre vélo ou entraîner l'annulation de la garantie.

ATTENTION :

Ne pas suivre les instructions ou utiliser le vélo de manière inappropriée peut provoquer des blessures légères. Ces tâches impliquent une difficulté technique et, si elles ne sont pas effectuées correctement, elles pourraient provoquer des dommages sur votre vélo ou entraîner l'annulation de la garantie.

INFORMATIONS

Informations indispensables à la réalisation correcte de cette tâche en évitant de causer des dommages au vélo ou de perdre la garantie, mais qui ne présentent aucun risque pour les personnes.

AUTRES CONSIDÉRATIONS

- L'utilisation de pièces de rechange non originales peut entraîner des dommages, des dysfonctionnements et des accidents aux conséquences graves..
- Pour effectuer certaines des opérations décrites dans ce manuel, des qualifications supérieures à celles de l'utilisateur de vélo moyen sont nécessaires. Si vous ne pouvez pas suivre l'une de ces étapes, apportez votre vélo auprès d'un revendeur Mondraker agréé pour effectuer l'entretien et le remplacement de ses composants. L'installation incorrecte de pièces de rechange peut entraîner des dysfonctionnements, des accidents, des blessures et l'annulation de la garantie.

NETTOYAGE ET ENTRETIEN

- Une fois les pièces démontées, il est recommandé de nettoyer, de graisser et de mettre du frein filet (si nécessaire) sur les composants que vous comptez réutiliser.

LÉGENDE DES SYMBOLES



Frein filet de niveau moyen. Loctite 243 ou similaire.



Graisse synthétique de qualité pour montage.



Graisse spéciale de friction pour carbone.



1. GÉOMÉTRIE

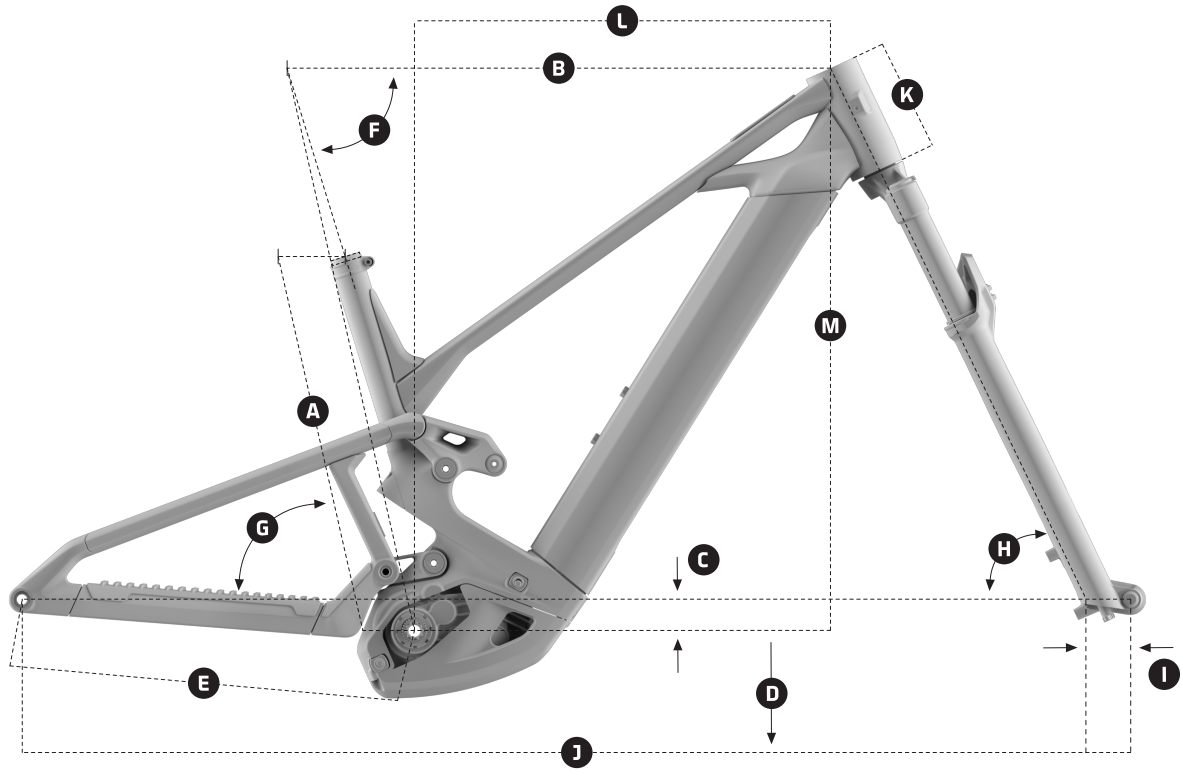

SCREE

TAILLE DU CADRE	S	M	ML	L	XL
A Longueur du tube de selle	380 mm	410 mm	435 mm	460 mm	490 mm
B Longueur du tube supérieur	587,6 mm	607,6 mm	628,8 mm	650,7 mm	672,8 mm
C Différence axe boîtier/axe moyeu	-35 mm	-35 mm	-35 mm	-35 mm	-35 mm
D Hauteur de pédalier	340 mm	340 mm	340 mm	340 mm	340 mm
E Longueur des bases	456 mm	456 mm	456 mm	456 mm	456 mm
F Angle de tube de selle	74°	74°	74°	74°	74°
G Angle de tube de selle effectif	77°	77°	77°	77°	77°
H Angle du tube de direction	65,5°	65,5°	65,5°	65,5°	65,5°
I Déport de fourche	44 mm	44 mm	44 mm	44 mm	44 mm
J Empattement	1221,2 mm	1241,2 mm	1263,3 mm	1287,4 mm	1311,5 mm
K Longueur du tube de direction	125 mm	125 mm	130 mm	140 mm	150 mm
L Reach	440 mm	460 mm	480 mm	500 mm	520 mm
M Stack	644,6 mm	644,6 mm	649,2 mm	658,3 mm	667,4 mm



2. SPÉCIFICATIONS TECHNIQUES DU CADRE

TAILLE DE CADRE	S / M / ML / L / XL
TAILLE ROUE AVANT (pouces)	29"
AXE AVANT	110mm x 15mm (BOOST)
TAILLE ROUE ARRIÈRE (pouces)	29"
AXE ARRIÈRE	148mm x 12mm (BOOST)
ESSIEU ARRIÈRE	12X148 P1.0 L180
NOMBRE D'EMPLACEMENTS PORTE-BIDONS	2 POSITIONS, 1 PORTE-BIDONS / RANGE EXTENDER
MOTEUR	BOSCH PERFORMANCE LINE CX
BOÎTIER DE PÉDALIER	BOSCH
BATTERIE	800Wh / 600Wh
COMPATIBILITÉ AVEC RANGE EXTENDER	BOSCH POWERMORE 250Wh
DÉBATTEMENT ARRIÈRE	130mm
AMORTISSEUR ARRIÈRE	165 x 45mm TRUNNION, 30 x 8mm
DÉBATTEMENT AVANT	150mm
DIAMÈTRE DE LA TIGE DE SELLE	31.6mm / 34.9mm
LIGNE DE CHAÎNE DIRECTION	55mm
JEU DE DIRECTION	ZS56 / ZS56, 1-1/8", 1.5"
NOMBRE DE DENTS MAXIMAL (PLATEAU)	34T
FREIN ARRIÈRE	POST MOUNT, DIRECT 220mm max
DÉGAGEMENT MAXIMAL PNEUS	29" x 2.6" (66-622)

3. PROFONDEUR D'INSERTION DE TIGE

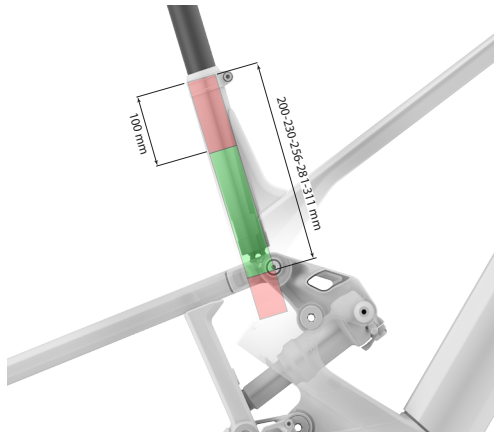

TAILLE CADRE	MIN. (mm)	MAX. (mm)
XL	100	311
L	100	281
ML	100	256
M	100	230
S	100	200



4. COMPOSANTS TRANSMISSION

4.1. GUIDE CHAÎNE

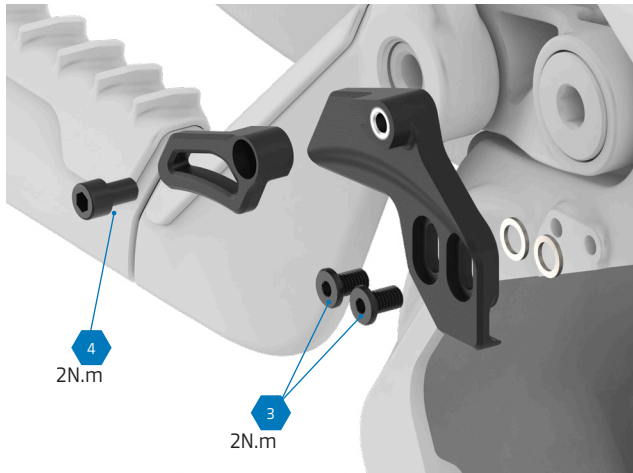

4.2. PLATEAU



Consultez le manuel du fabricant du plateau pour savoir s'il est compatible avec un joint torique.

5. COUVERCLE DU MOTEUR

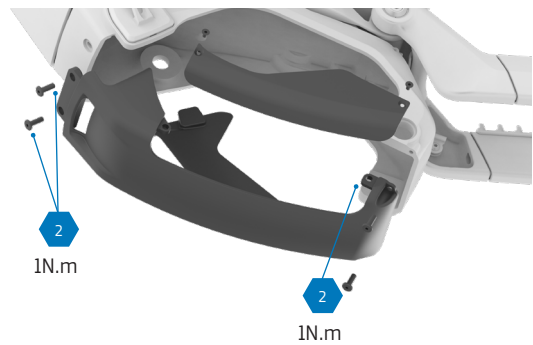
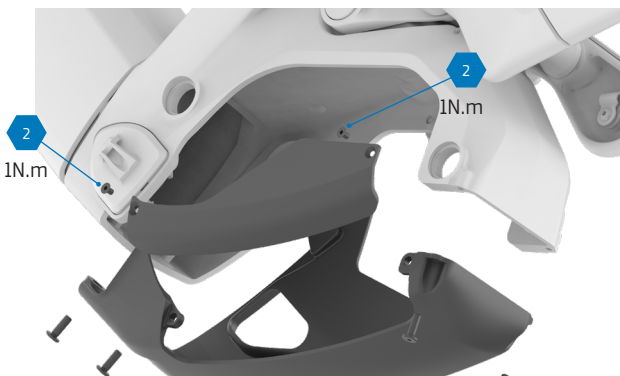



6. RETIRER LE MOTEUR



Ne pas utiliser Loctite 243

6.1. CONNEXIONS DU MOTEUR

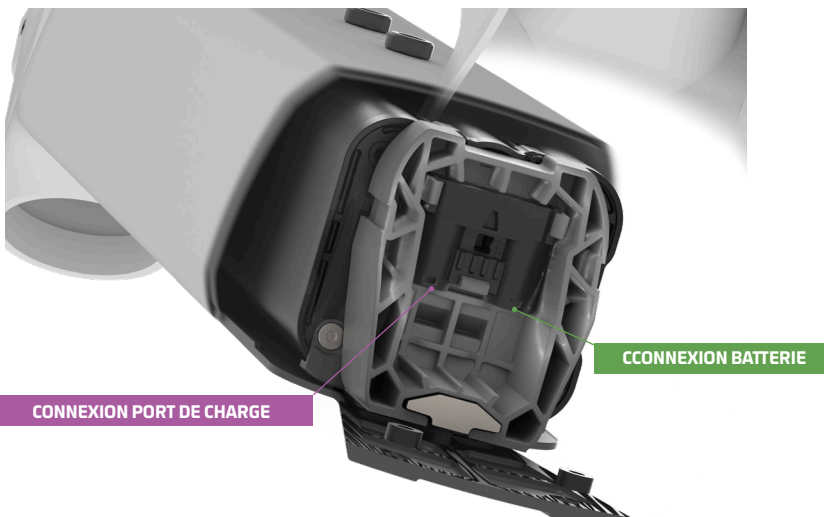
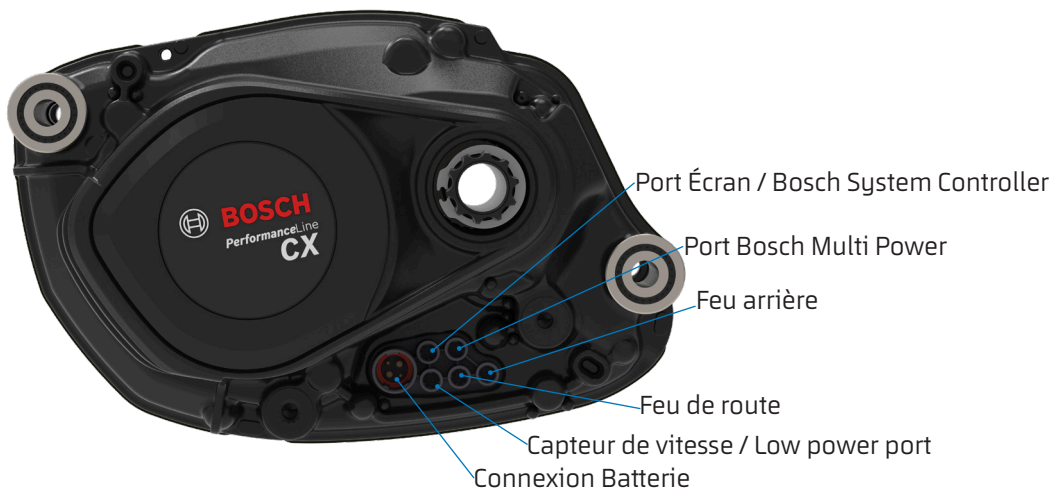



7. PORT DE CHARGEMENT

7.1. RETIRER LE PORT DE CHARGE

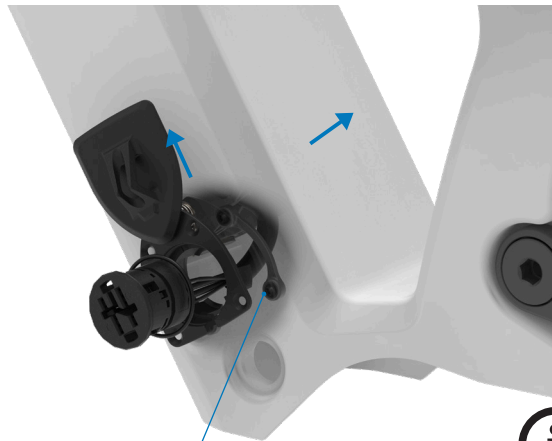
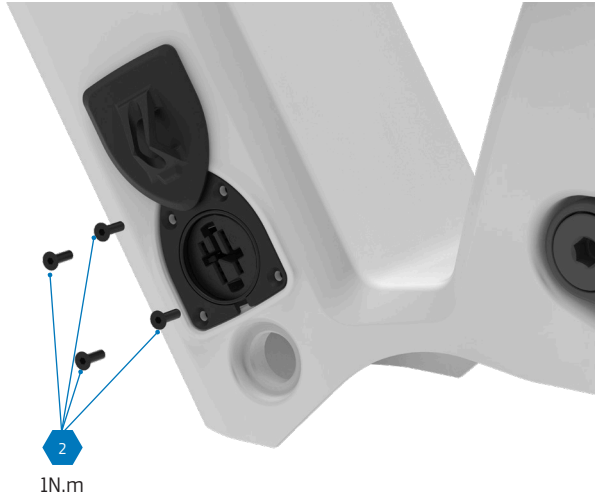

Libérer le couvercle latéralement



Les 2 bases métalliques
sortent de l'intérieur du
tube diagonal





8. DÉMONTAGE DE LA BATTERIE

ÉTAPE 1

Dévissez la première section filetée. La batterie sort et reste fixée au cadre.

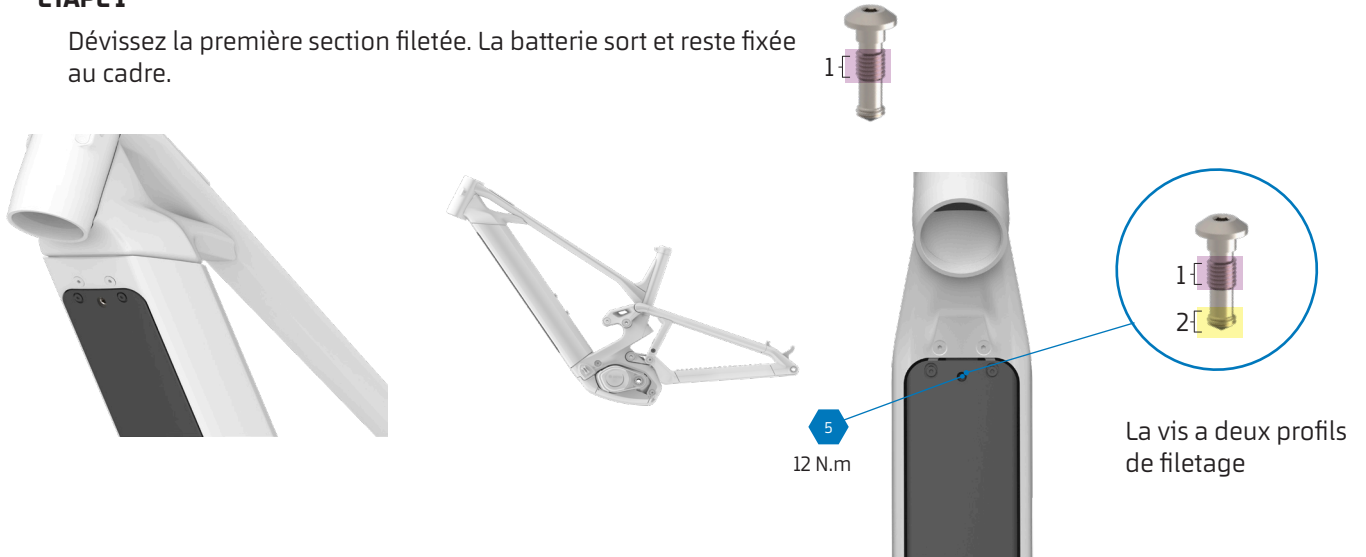

FIN DE L'ÉTAPE 1

Lors de cette étape, tenez la batterie avec votre main et continuez à dévisser la deuxième section de la vis filetée.

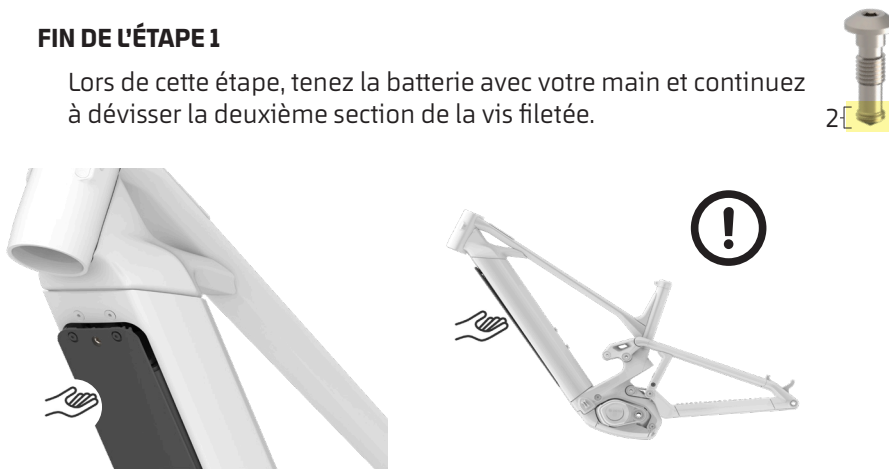

ÉTAPE 2

La batterie se détachera. Attention, la batterie est lourde. Si vous ne la tenez pas fermement, elle risque de heurter le sol et d'être définitivement endommagée.

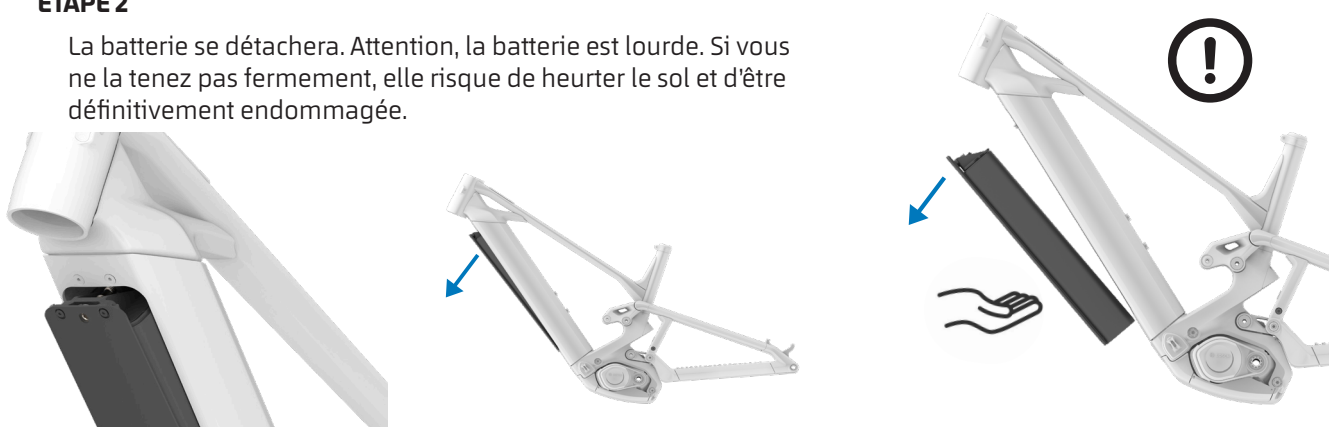



9. PASSAGE INTERNE DES CÂBLES

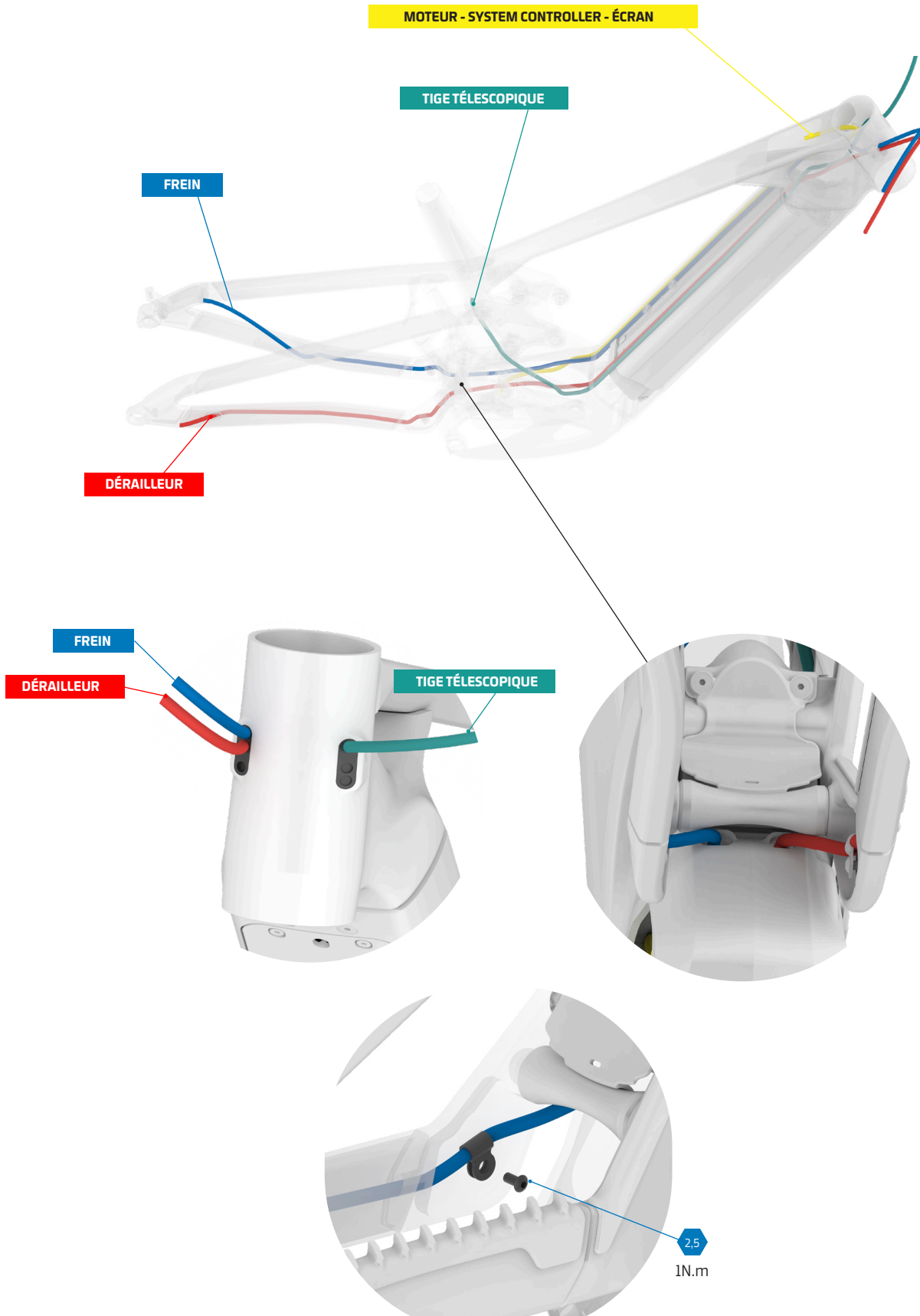



10. FIXATION DE LA BATTERIE

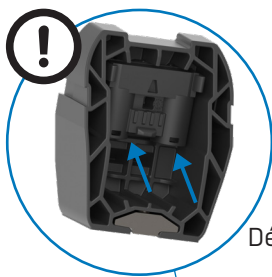
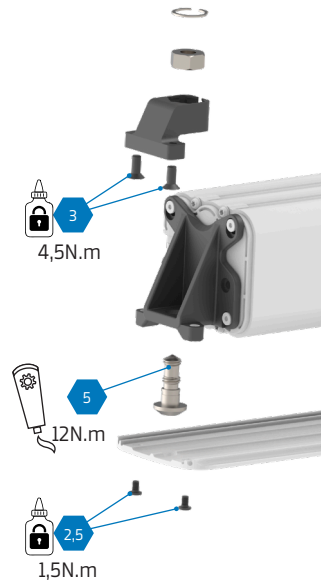
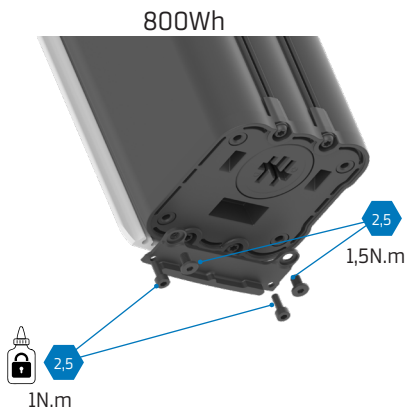
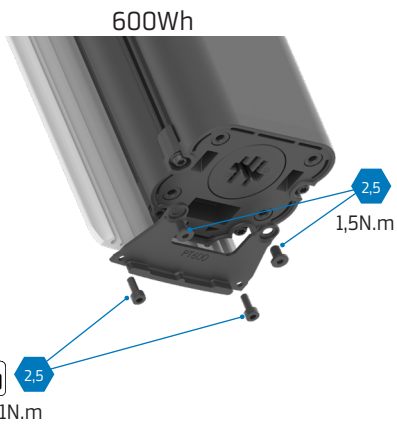
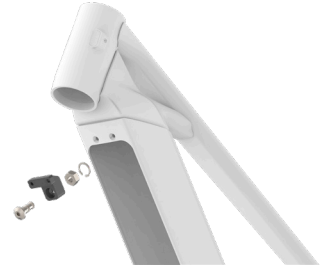
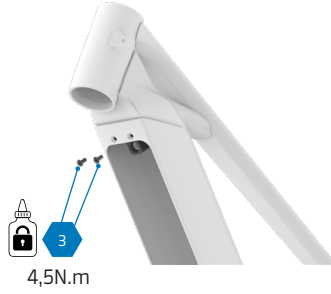
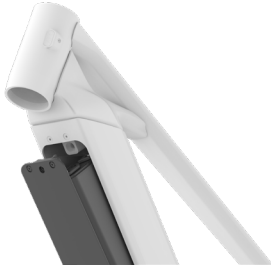

Déconnecter les câbles





11. CHANGEMENT DES BATTERIES 600 WH / 800 WH

11.1 INSTALLATION DES FIXATIONS DE LA BATTERIE

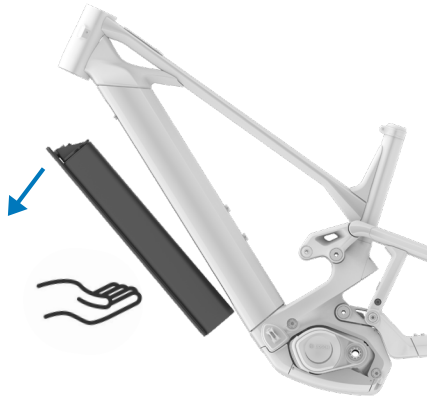

600Wh



800Wh

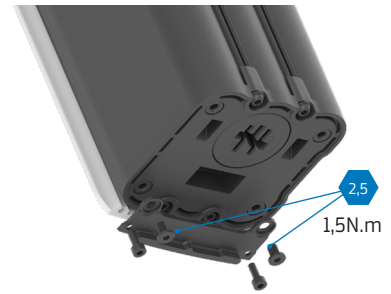

600Wh

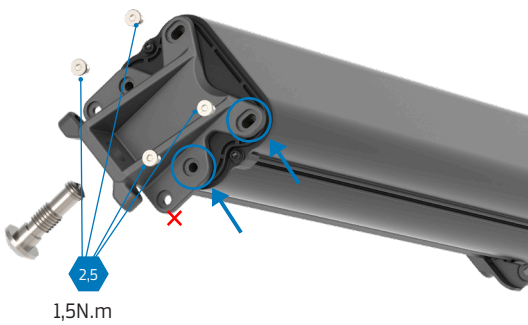

800Wh

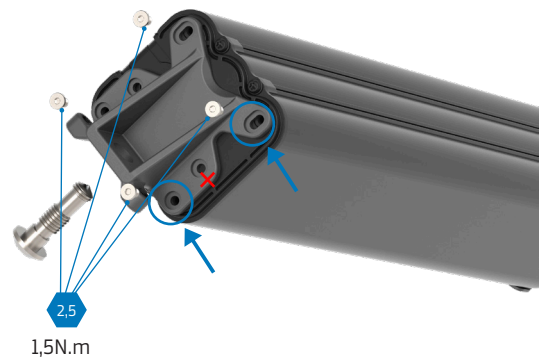



11. CHANGEMENT DES BATTERIES 600 WH / 800 WH

11.2. INSTALLATION DU COUVERCLE DE LA BATTERIE

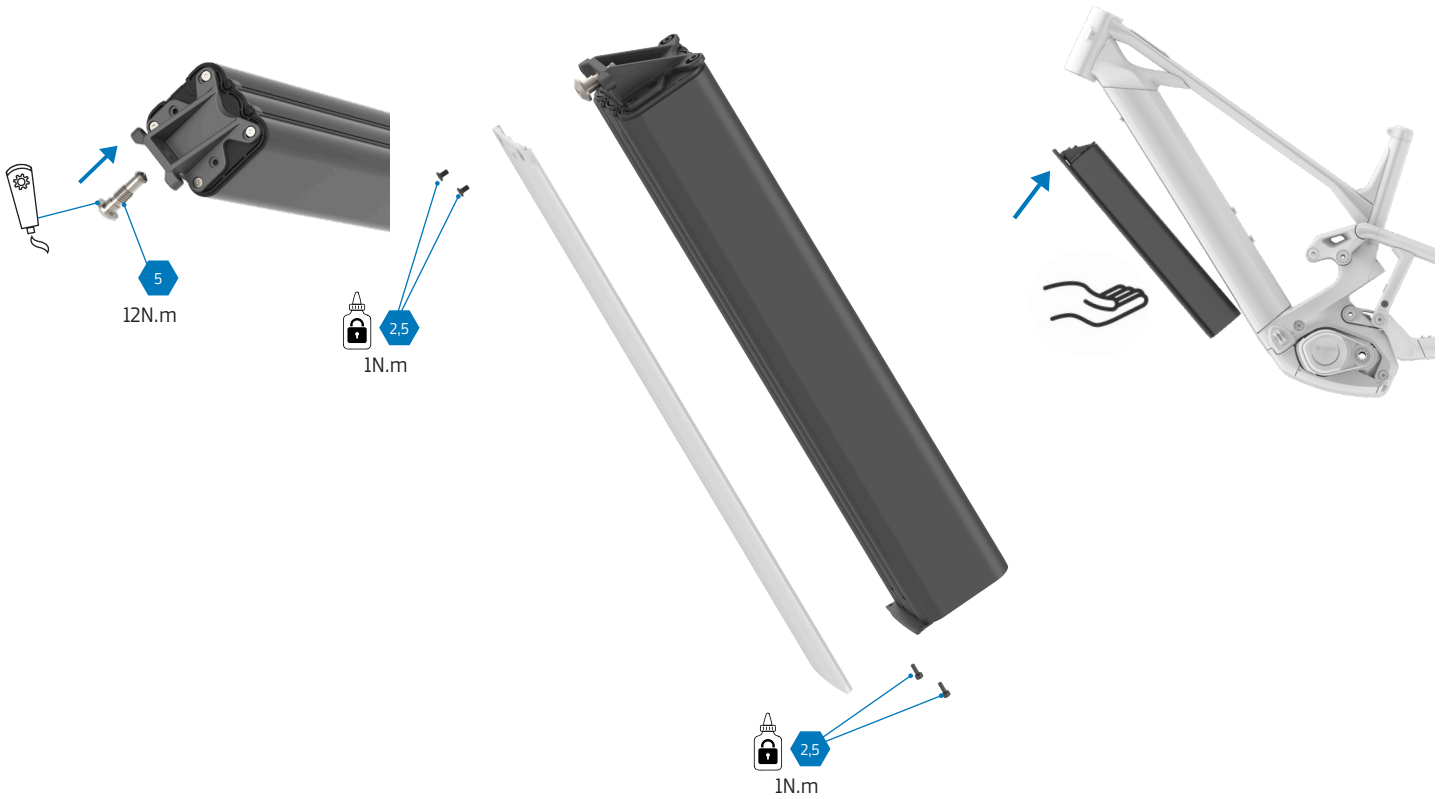

8. 4. RÉFÉRENCES SUPPORT BATTERIE



SUPPORT DE BATTERIE
AVANT 800Wh/600Wh
Ref. 099.25049



SUPPORT DE BATTERIE
ARRIÈRE 800Wh
Ref. 099.26020



SUPPORT DE BATTERIE
ARRIÈRE 600Wh
Ref. 099.26021



8. 5. LES PIÈCES DE RECHANGE NÉCESSAIRES POUR UNE DEUXIÈME BATTERIE

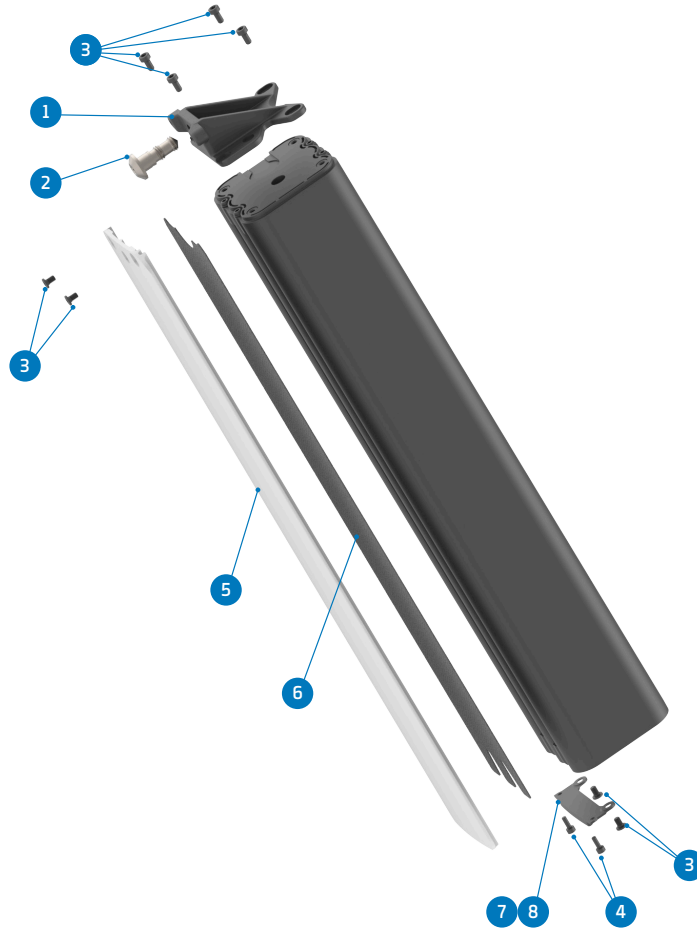

ITEM	DESCRIPTION	QTY.	PART NUMBER
1	BATTERY MOUNT BRACKET FRONT	1	099.25049
2	BATTERY RELEASE SCREW	1	099.25051
3	SCREW BOLT M4X6	8	099.25052
4	SCREW BOLT M4X8	2	099.12116
5	BATTERY COVER	1	Refer to B2B web for color options
6	FOAM FOR BATTERY COVER	1	099.25089
Choose between:			
7	BATTERY HOLDER REAR 800Wh (only for 800Wh battery)	1	099.26020
8	BATTERY HOLDER REAR 600Wh (only for 600Wh battery)	1	099.26021
9	FOAM FOR 600Wh BATTERY (only 600wh battery)	1	099.25097



SUPPORT DE BATTERIE
ARRIÈRE 800Wh
Ref. 099.26020

SUPPORT DE BATTERIE
ARRIÈRE 600Wh
Ref. 099.26021



9. PLAQUES DE MOUSSE

9.1. INSTALLATION DE LA FEUILLE DE MOUSSE POUR LE CADRE

Ref. 099.25088



10. BOSCH SYSTEM CONTROLLER KIOX 400

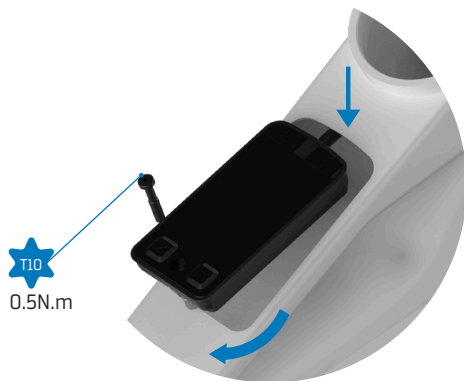

11. BOSCH MINI REMOTE



12. CHAINSTAY PROTECTOR



Les protecteurs de base sont livrés sans trou pour les dérailleurs mécaniques ou avec câble. À l'arrière, il y a une marque indiquant où percer la sortie du câble

Pour un résultat optimal, il est recommandé d'utiliser des pinces de perforation.



13. RANGE EXTENDER BOSCH POWERMORE KIT

EU28, CH, NO, AUS, NZ

POWERMORE 250 KIT (BBP3620 EU28,CH,NO,AUS,NZ)
incl. battery holder, bottle holder, screws, IBD packaging
EB12.100.05G

US, CANADA

POWERMORE 250 KIT (BBP3625 US, CAN) incl.
battery holder, bottle holder, screws, IBD packaging
EB12.100.05H



CABLE POWERMORE 150MM (BCH3923_150) **EB12.120.036**



14. GARDE-BOUE

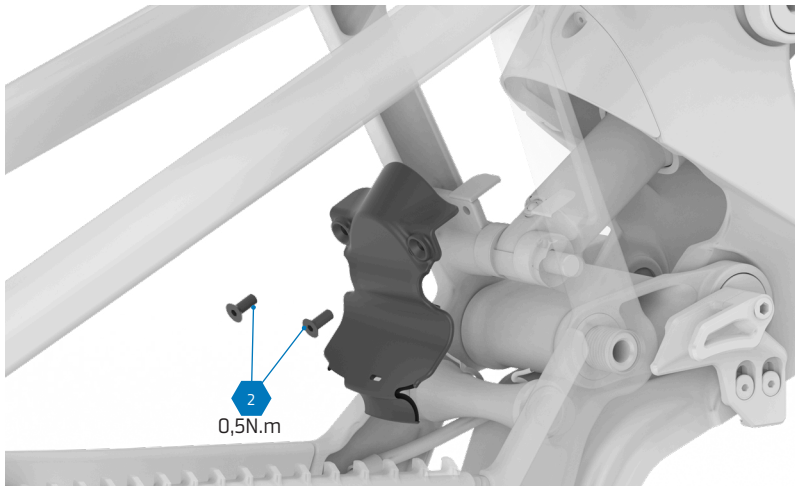
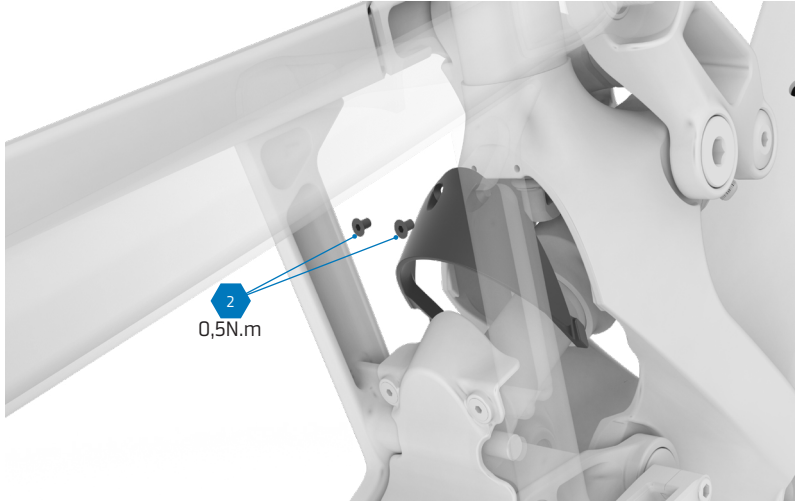

15. COLLIER DE SELLE

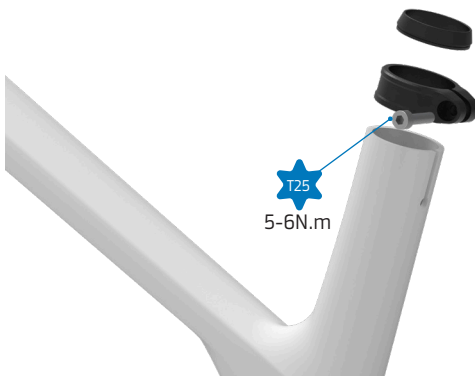

Il est recommandé d'utiliser de la graisse de friction pour carbone sur la tige de selle



16. GUIDE D'INSTALLATION DE LA BIELLETTE SUPÉRIEURE

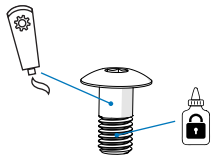
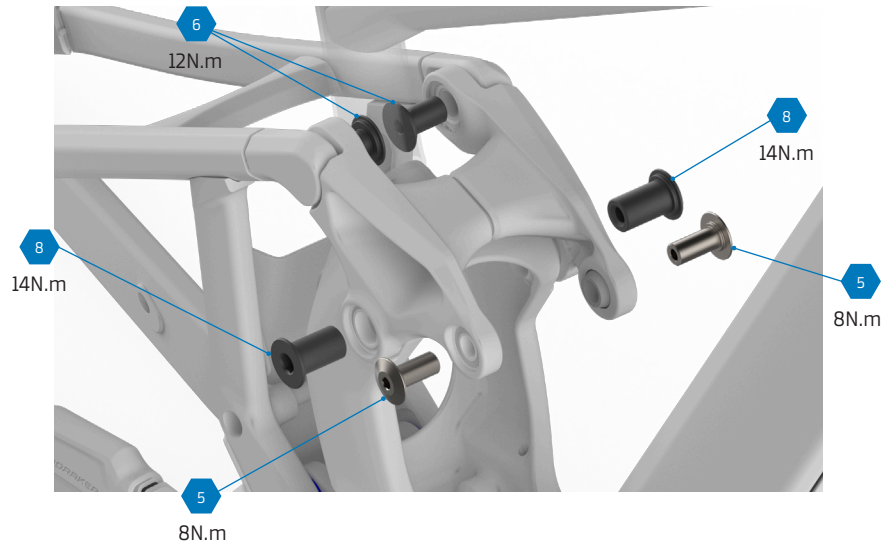

! Pour les vis principales, appliquez de la graisse sur la tige, et du Loctite 243 ou similaire sur les filetages

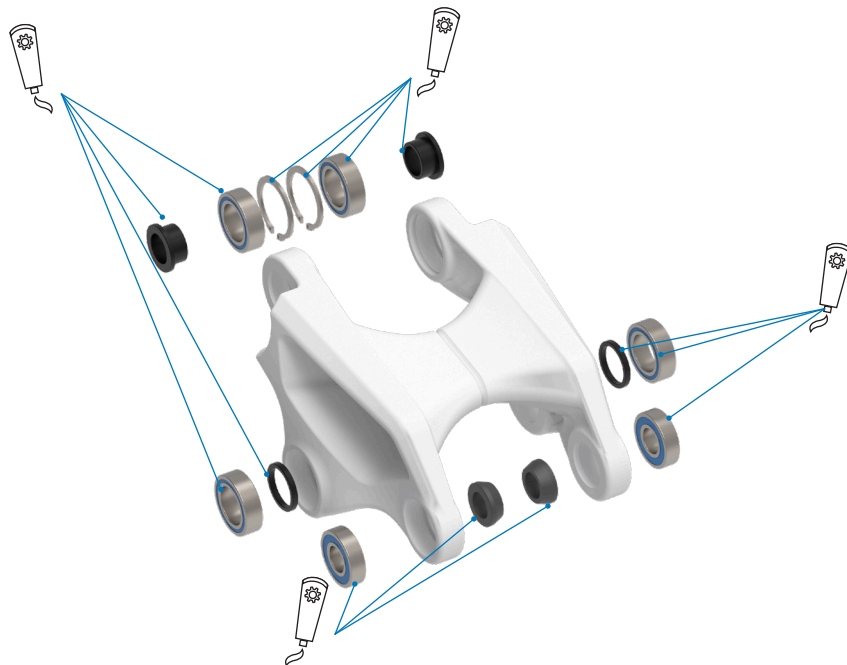

! Appliquez de la graisse.



17. GUIDE D'INSTALLATION DE LA BIELLETTE INFÉRIURE

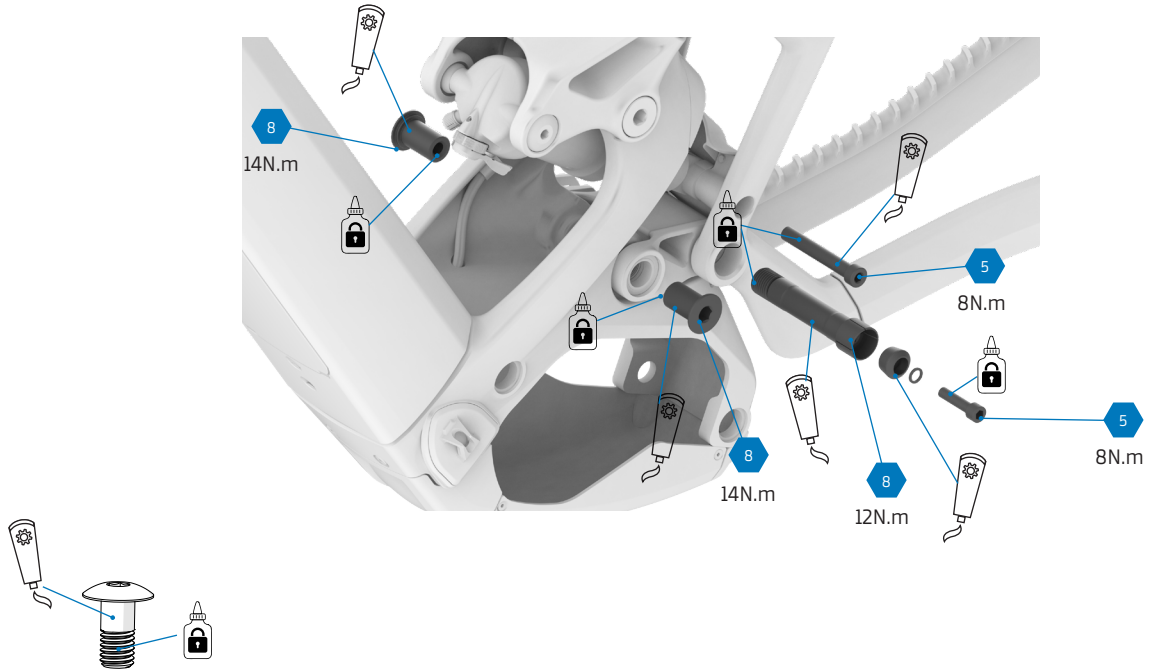

Pour les vis principales, appliquez de la graisse sur la tige, et du Loctite 243 ou similaire sur les filetages

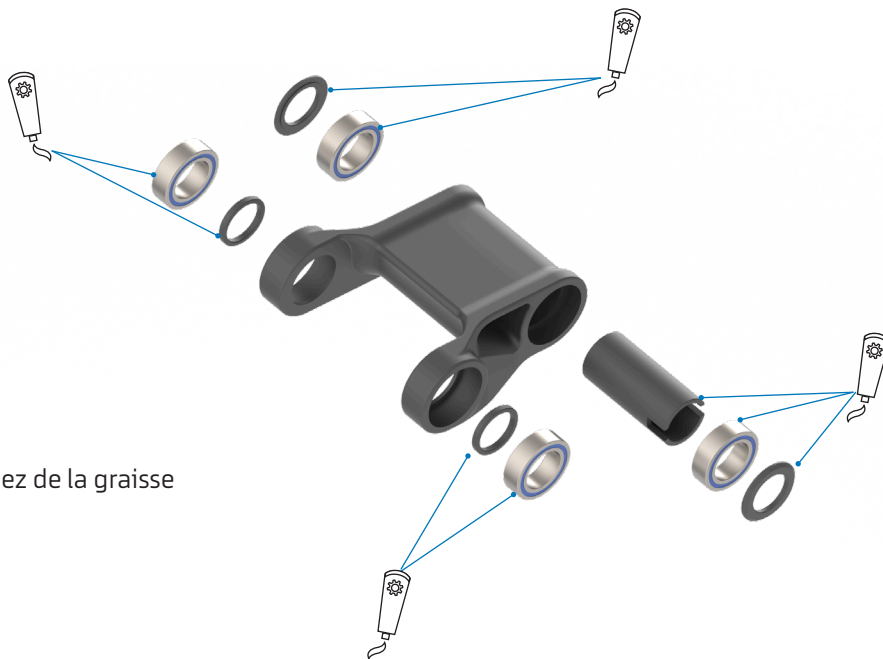

Appliquez de la graisse



19. CONNEXION À UN SMARTPHONE



eBike Flow app



Allumez le vélo.
Une fois allumé, appuyez pendant 5 secondes sur le bouton Power jusqu'à ce qu'une LED bleue commence à clignoter.
Ouvrez alors l'application eBike Flow et suivez les instructions sur votre téléphone pour effectuer l'appairage.

20. MONTAGE DE LA POTENCE

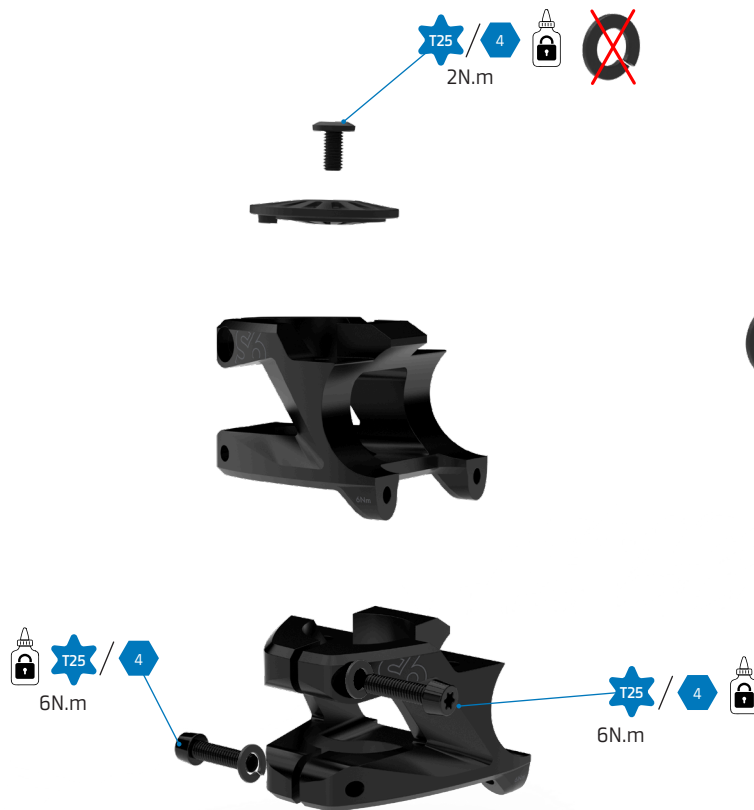

Les 6 vis de la potence, à l'exception de celle du capot de direction, doivent être équipées d'une rondelle fendue

1. Insertion de la potence

Glissez le corps de la potence sur le tube de direction de la fourche jusqu'à ce qu'il soit correctement en place.

2. Réglage de la direction (Précontrainte)

Placez le capuchon supérieur de direction (top cap) et sa vis correspondante. Serrez la vis supérieure à un couple maximum de 1 Nm pour précharger les roulements et éliminer tout jeu dans la direction.

3. Serrage des vis latérales

Alignez la potence avec la roue avant. Serrez les vis latérales de fixation progressivement et en alternance pour répartir la charge. Augmentez la tension de manière progressive (par ex., la vis supérieure à 4 Nm, la vis inférieure à 4 Nm, puis les deux à 5 Nm) jusqu'à ce que les deux vis atteignent le couple de serrage final exact de 6 Nm.

Conseil de montage :

Il est plus facile d'aligner visuellement la potence avec la roue avant si le cintre est déjà installé. Pour ce faire, effectuez cette étape en n'appliquant qu'une légère tension sur les vis latérales, passez au Montage du cintre (Section 2), effectuez l'alignement final de l'ensemble et, enfin, appliquez le couple de serrage définitif de 6 Nm sur les vis latérales de la fourche.

21. MONTAGE DU CINTRE

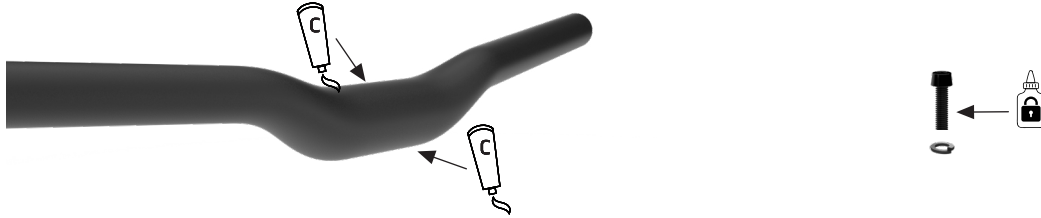

Appliquez une fine couche de pâte de montage spécifique pour le carbone sur la zone de contact entre le cintre et la potence. Si les filetages des vis sont secs, appliquez une petite goutte de LOCTITE 243.

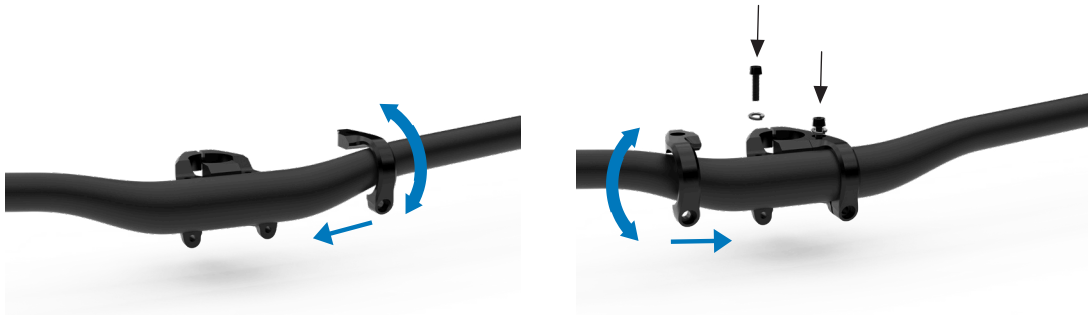

Insérez la plaque frontale de la potence par la partie la plus étroite du cintre et faites-la glisser vers le centre avec précaution pour éviter de rayer la surface du composant. Ajustez-la et insérez la vis supérieure pour la maintenir en place. Ne serrez pas au couple final.



Placez les deux vis supérieures et vissez-les de plusieurs tours à la main sans appliquer le couple de serrage final. Ensuite, insérez les deux vis inférieures sans les serrer.

Remarque : S'il est difficile d'aligner ou de visser les vis inférieures, desserrez légèrement les vis supérieures pour faciliter l'insertion et réessayez.



21. MONTAGE DU CINTRE

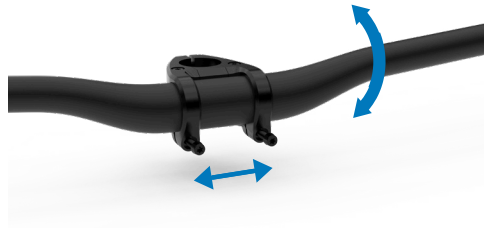

Ajustez la rotation et le centrage du cintre jusqu'à atteindre la position souhaitée.

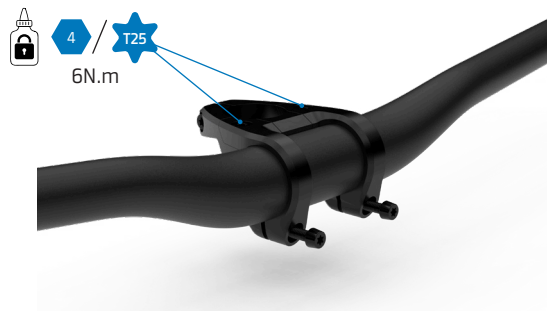

Serrez les vis supérieures progressivement et en alternant les côtés. Augmentez la tension de manière progressive (par ex. 4 Nm, puis 5 Nm de chaque côté) jusqu'à atteindre le couple de serrage final exact de 6 Nm. Il est d'une importance vitale que les deux vis supérieures soient complètement fixées à 6 Nm lors de cette étape.

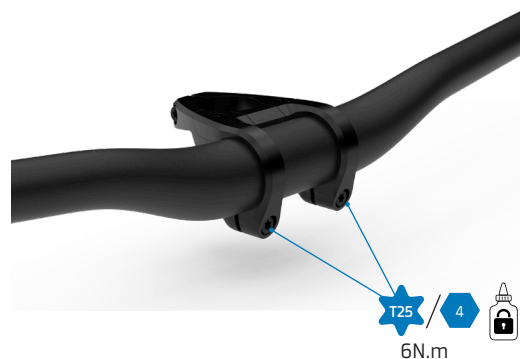

Avec le cintre dans sa position définitive, serrez les vis inférieures progressivement et en alternant entre le côté gauche et le côté droit (4 Nm, 5 Nm et enfin 6 Nm) pour répartir la charge uniformément.

Vérifiez visuellement le bon alignement et couplage de la potence. De par sa conception, il ne doit y avoir aucun espace entre les pièces dans la partie supérieure ; l'interstice de serrage doit se situer exclusivement dans la partie inférieure. Enfin, vérifiez à l'aide de la clé dynamométrique que les quatre vis sont maintenues au couple spécifié de 6 Nm. Nettoyez ensuite tout excès de graisse éventuel.



22. SPARE PARTS
SCREE

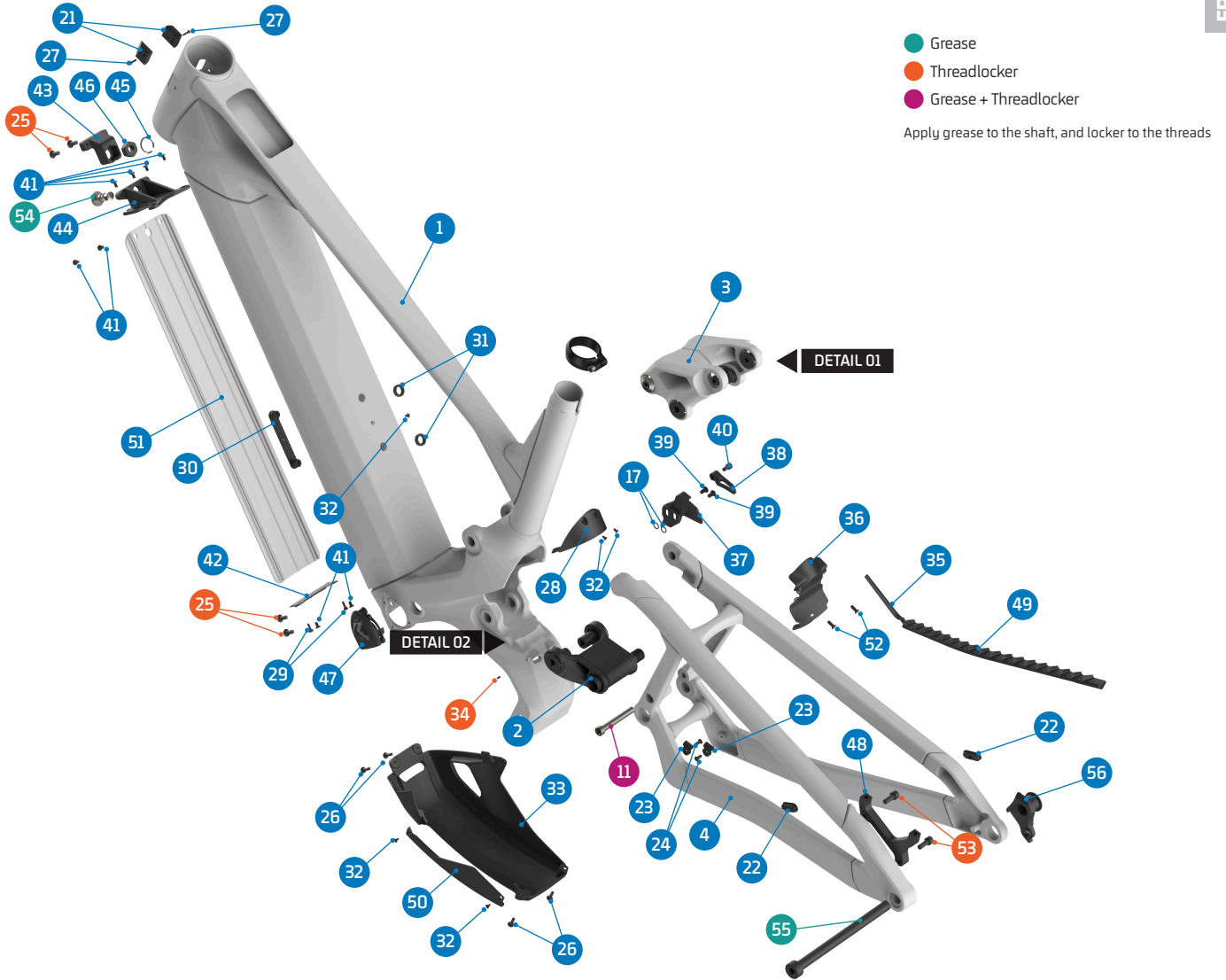

ITEM No.	DESCRIPTION	QTY.	PART NUMBER	TORQUE
1	FRONT TRIANGLE	1		
2	SCREE LOWER LINK	1	099.26009	
3	SCREE UPPER LINK	1	Refer to B2B web for color options	
4	SCREE REAR TRIANGLE	1		
5	BEARING, 24X15X7 (3802-2RS)	8	SET 1	
6	BEARING, 10x22x6 (6900V-2RS)	2	SET 1	
7	C-RING	2	SET 3	
8	MAIN AXLE	1	SET 4	12Nm
9	UPPER LINK-RT SPACER	2	SET 3	
10	PIVOT AXLE, M12	2	SET 3	12Nm
11	SHOCK BOLT	1	SET 2 / 099.24022	8Nm
12	SPACER	1	SET 4	
13	SPACER, 15x27x2	2	SET 4	
14	SPACER, 10x17x6	2	SET 2	
15	SPACER, 15x19x2.5t	4	SET 3 / 4	
16	TAPER NUT	1	SET 4	
17	SPACER	3	SET 4 / 5	
18	SCREW BOLT, M6x25	1	SET 4	8Nm
19	PIVOT AXLE, M15	4	SET 3 / 4	14Nm
20	SHOCK BOLT	2	SET 2	8Nm
21	CABLE GUIDE	2	SET 7	
22	CABLE RUBBER	2	989.13010	
23	SINGLE CABLE GUIDE	2	099.22064	
24	SCREW BOLT, M4x8	2		1Nm
25	SCREW BOLT, M5x12	4	099.12141	4,5Nm
26	SCREW BOLT, M4x12	4	099.20078	
27	SCREW BOLT, M3x10	2	SET 7	1Nm
28	SCREE FRONT TRIANGLE FENDER	1	099.26016	
29	SCREW BOLT, M3x8	2	099.12116	2Nm

ITEM No.	DESCRIPTION	QTY.	PART NUMBER	TORQUE
30	BOTTLE CAGE STAND	1	099.25072	
31	BOTTLE CAGE STAND SPACERS	2	099.25074	
32	SCREW BOLT, M3x5	5	099.25028	2Nm
33	MOTOR COVER	1	099.26017	
34	SCREW BOLT, M3x5	1		1Nm
35	CHAINSTAY PROTECTOR YOKE	1	099.26018	
36	REAR TRIANGLE FENDER	1	099.26019	
37	CHAIN GUIDE, BASE	1	SET 5	
38	CHAIN GUIDE, OUTER	1	SET 5	
39	SCREW BOLT, M5x12	2	SET 5	2Nm
40	SCREW BOLT, M5x8	1	SET 5	2Nm
41	SCREW BOLT, M4x6	8	099.25052	1,5Nm
42	COVER BRACKET 800WH	1	099.26020	
	COVER BRACKET 600WH	1	099.26021	
43	BATTERY MOUNT	1	099.25082	
44	BATTERY MOUNT BRACKET	1	099.25049	
45	C-RING	1	099.25083	
46	NUT	1	099.25084	
47	CHARGE PLUG SET	1	099.24064	
48	DISC MOUNT	1	SET 6	
49	CHAINSTAY PROTECTOR	1	099.26022	
50	SKID PLATE LEFT SIDE COVER	1	099.26023	
51	BATTERY COVER	1	Refer to B2B web for color options	
52	SCREW BOLT, M4x10	2		1 Nm
53	SCREW BOLT, M6x15	2	SET 6	12Nm
54	BATTERY RELEASE SCREW	1	099.25051	12Nm
55	REAR AXLE	1	112.90027	
56	HANGER	1	SRAM UDH	



DETAIL 01

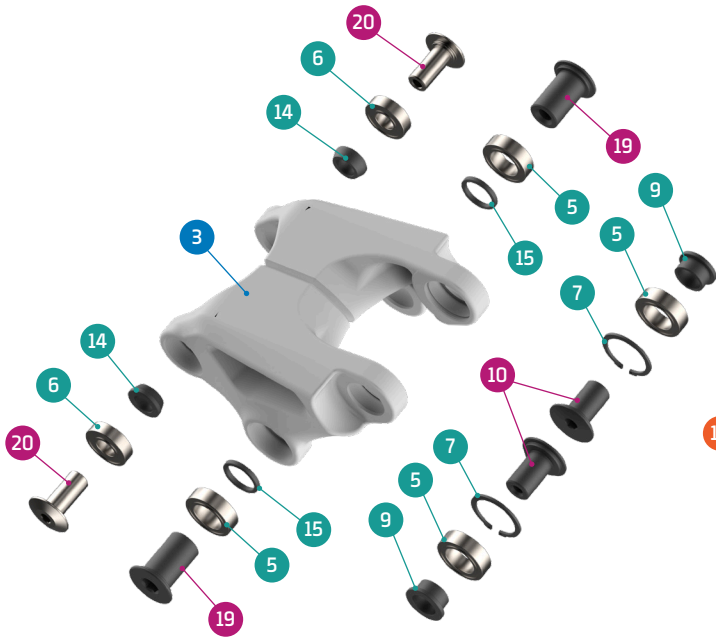

DETAIL 02

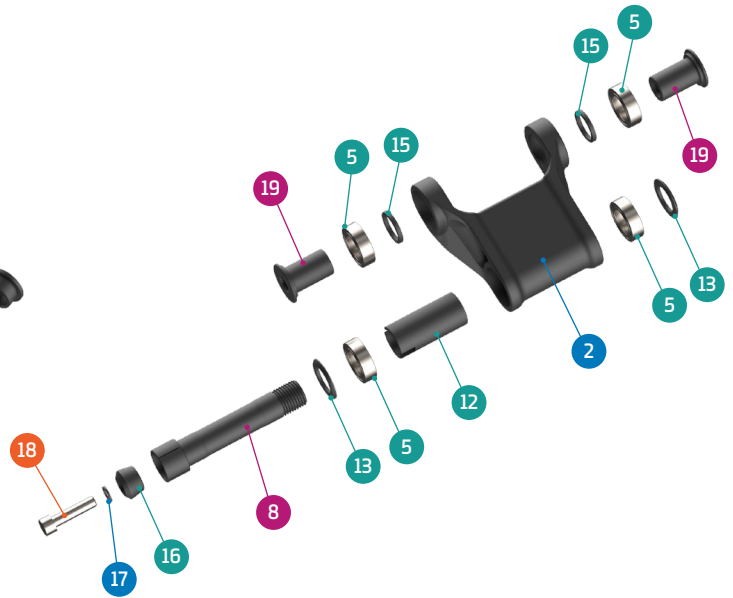

FOAM FOR BATTERY (600WH)

FOAM FOR MAIN TUBE

FOAM FOR BATTERY COVER

SET 7

SET 6

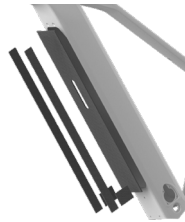

CABLE GUIDE KIT

DISC ADAPTOR KIT

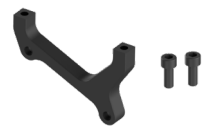

SET 1

SET 2

SET 3

SET 4

SET 5

ZERO BEARING KIT 26

SHOCK HARDWARE KIT 22

UPPER LINK KIT 30

LOWER LINK KIT 37

CHAIN GUIDE PLATE + BOLTS



PART NUMBER	DESCRIPTION	COMPONENTS
099.22101	SET 1: ZERO BEARING KIT 26	BEARING 3802-2RS, 24x15x7 (x8) / BEARING 6900V-2RS, 10x22x6 (x2)
099.24200	SET 2: SHOCK HARDWARE KIT 22	SPACER (x2) / SHOCK BOLT (x2) / SHOCK BOLT (x1)
099.22300	SET 3: UPPER LINK KIT 30	SPACER, 15x19x2.5T (x2) / UPPER LINK-RT SPACER (x2) / PIVOT AXLE, M12 (x2) / PIVOT AXLE, M15 (x2) / C-RING (x6)
099.25400	SET 4: LOWER LINK KIT 37	SPACER, 15x27x2 (x2) / SPACER, 15x19x2.5t (x2) / INNER LOWER LINK SPACER (x1) / PIVOT AXLE, M10 (x1) / AXLE NUT, M10 (x1) / MAIN AXLE (x1) / SPACER (x1) / TAPER NUT (x1) / SCREW BOLT (x1)
099.24018	SET 5: CHAIN GUIDE PLATE + BOLTS	CHAIN GUIDE BASE (x1) / CHAIN GUIDE OUTER PLATE (x1) / SCREW BOLT, M5x12 (x2) / SCREW BOLT, M5x8 (x1) / WASHER 5x9x1t (x4)
099.25018	SET 6: DISC ADAPTOR KIT	DISC ADAPTOR (x1) / SCREW BOLT (x2)
099.25013	SET 7: CABLE GUIDE KIT	CABLE GUIDE (x1) / SCREW BOTL M2.5X5L (x1) / SCREW BOLT M3X10L (x1)
099.25088	FOAM KIT FOR MAIN TUBE	
099.25089	FOAM FOR BATTERY COVER	
099.25097	FOAM FOR 600Wh BATTERY	



23. FAQS

QUELLE EST LA DIFFÉRENCE ENTRE LE NOUVEAU SCREE ET LE CRAFTY CARBON ?

Le Scree tout comme le Crafty Carbon sont les e-MTB les plus polyvalents de Mondraker, mais tous deux sont conçus pour des usages différents, avec des cadres, des cinématiques, une géométrie et un débattement de suspension spécifiques. Scree est un tout nouveau modèle entièrement Trail, avec 130 mm de débattement sur la roue arrière et 150 mm à l'avant, monté sur un cadre Stealth en aluminium, tandis que Crafty Carbon est un modèle Enduro avec un débattement plus important, 150 mm à l'arrière et 160 mm à l'avant, monté sur cadre Stealth Air Carbon. Les deux modèles sont équipés du nouveau moteur Bosch Performance CX Gen 5 et sont proposés avec des batteries de 600 Wh ou 800 Wh. Les deux gammes sont disponibles en 5 tailles, chacune avec une géométrie spécifique. Toutes deux sont équipées du moteur Bosch Performance CX dernière version, offrant jusqu'à 100 Nm et 750 W, compatible avec les batteries de 800 Wh et 600 Wh, pour une expérience de course optimale.

COMBIEN PÈSE LE NOUVEAU CADRE SCREE ?

Le cadre Scree peint, complet avec visserie et accessoires, sans amortisseur arrière, pèse environ 4,900 kg en taille ML.

QUELLE EST LA DIFFÉRENCE DE POIDS ENTRE LA BATTERIE 600 WH ET CELLE DE 800 WH ?

La Powertube 800 Wh pèse 3990 g, tandis que la nouvelle Powertube 600 Wh pèse 3070 g. Toutes deux sont équipées de cellules de batterie de dernière génération 21700.

QUELS AMORTISSEURS SONT COMPATIBLES AVEC LE NOUVEAU SCREE ?

Scree est compatible avec tout amortisseur inline, et sa cinématique a été optimisée pour ce type d'amortisseur. Vous pouvez également utiliser des modèles à réservoir déporté (piggyback) tels que ceux de la série Float X ou le RockShox SuperDeluxe. Pour les modèles de plus grand volume, il est indispensable de vérifier la compatibilité avant installation, car il se peut qu'ils ne rentrent pas. Scree utilise des amortisseurs de 165x45 mm, avec montage supérieur Trunnion et fixation standard 30x8 mm.

QUELLES CARACTÉRISTIQUES CINÉMATIQUES OFFRE LE TOUT NOUVEAU SCREE ?

Le design et la configuration Zero Suspension ont été mis à jour et améliorés avec les dernières évolutions observées sur les VTT tout-suspendus de nouvelle génération de Mondraker, et dans ce cas adaptées à une utilisation Trail très polyvalente. Scree a un taux de progression de 20,5 %, un ratio de levier plus élevé, ce qui le rend plus sensible et souple en début de course, ainsi que des courbes d'anti-squat et d'anti-rise légèrement plus faibles, pour une suspension arrière plus performante et plus capable dans l'ensemble.

QUEL EST LE DÉBATTEMENT MAXIMAL DE FOURCHE DU NOUVEAU SCREE ?

Scree est compatible avec des fourches allant jusqu'à 160 mm de débattement ou 580 mm de l'essieu à la couronne.

SCREE PERMET-IL L'UTILISATION D'UN DISQUE DE FREIN ARRIÈRE DE PLUS DE 220 MM ?

Oui, Scree est compatible avec des disques de frein arrière de 220 mm. Il est possible également de monter ce type de disque sur les modèles Crafty Carbon, même si ce n'est pas vraiment recommandé.

QUELLE LARGEUR MAXIMALE DE PNEU ADMET SCREE ?

Scree est compatible avec des pneus de 66 mm maximum, ce qui correspond à des pneus 29" x 2,6". Il est recommandé de mesurer le pneu avant l'installation, car la largeur réelle peut être différente selon le fabricant.



23. FAQS

SCREE EST-IL COMPATIBLE AVEC UNE ROUE ARRIÈRE DE 27,5 ?

Vous pouvez techniquement monter une roue arrière plus petite, de 27,5", mais le vélo n'a pas été conçu pour rouler sur une configuration mulet, et le moteur n'offrirait pas les performances optimales à cause de la modification du diamètre de la roue. La circonférence de roue plus petite aura des répercussions sur la précision de la lecture de la vitesse, et ne peut pas être ajustée. Par exemple, passer à une roue arrière de 27,5x2,6" réduira la vitesse d'assistance d'environ 1 à 2 km/h, et avec le capteur de vitesse fixé sur une roue de diamètre inférieur, il est possible que le moteur ne fonctionne pas correctement. La géométrie Scree serait également compromise, avec des angles qui changeraient de -1,5° et un boîtier de pédalier abaissé de -13 à -15 mm.

Et surtout : Mondraker n'offre aucune garantie si le vélo est utilisé avec une roue arrière autre que celle d'origine de 29"

EST-IL POSSIBLE D'AJOUTER UN PROLONGATEUR D'AUTONOMIE POUR AUGMENTER L'AUTONOMIE ET ROULER PLUS LONGTEMPS ?

Oui. Comme sur tous les derniers systèmes de moteur Bosch, il existe un prolongateur d'autonomie Powermore 250 Wh, à monter dans un porte-bidon. Il pèse 1450 g ou 1525 g avec le support Bosch spécifique pour le côté et le câble de connexion. Vous profiterez d'une plus longue autonomie par rapport aux batteries Powertube de 600 Wh (+40 %) ou de 800 Wh (+30 %).

QUE FAUT-IL PRENDRE EN CONSIDÉRATION LORS DE L'INSTALLATION DE POWERMORE ?

Bosch propose différentes tailles de câble de connexion pour le prolongateur d'autonomie Powermore, mais pour tous les modèles et tailles de Scree, vous devrez utiliser le câble de 150 mm. Numéro de pièce Bosch : BCH3923_150 / EB12.120.036. Il est également important de noter qu'il y a 2 types de Powermore, selon votre région : PowerMore, EU28,CH,NO,AUS,NZ (n° de pièce Bosch BBP3620 / EB12.100.05G) et US, CAN, KOR (n° de pièce Bosch BBP3625 / EB12.100.05H)

PUIS-JE TRANSPORTER UN BIDON ?

Oui. Il y a 2 emplacements possibles pour un porte-bidon : sur le cadre principal, c'est-à-dire la position standard, et sous le tube supérieur.

LE PASSAGE DE CÂBLES EST EXTERNE SUR LES CÔTÉS DE LA DOUILLE DE DIRECTION : EST-IL POSSIBLE DE LES FAIRE PASSER À L'INTÉRIEUR À TRAVERS LA DIRECTION, COMME SUR D'AUTRES MODÈLES ?

Oui. La nouvelle cuvette supérieure du jeu de direction est conçue pour permettre un passage entièrement interne, si vous préférez cette configuration.

EST-IL POSSIBLE DE DÉMONTER LA BATTERIE INTERNE ?

Oui. Le nouveau Scree permet de retirer facilement la batterie interne. Il suffit de dévisser la vis Allen de 5 mm située sur la partie supérieure du tube principal. La batterie pourra alors être retirée pour être chargée en dehors du vélo, remplacée, nettoyée, ou bien pour effectuer l'entretien du vélo.



23. FAQS

IL Y A 2 TAILLES DE BATTERIES : 800 WH ET 600 WH. SONT-ELLES COMPATIBLES AVEC SCREE ?

Oui. Tous les modèles Scree peuvent utiliser indifféremment les batteries Powertube 800 Wh ou 600 Wh. Si votre vélo est livré avec l'une ou l'autre, vous pouvez acheter une batterie supplémentaire et l'installer selon vos besoins. Assurez-vous également de disposer des adaptateurs nécessaires (pour monter la batterie 600 Wh si votre vélo est livré d'origine avec la batterie 800 Wh, et inversement, car les hauteurs de batterie sont différentes, tout comme les adaptateurs) afin que la batterie s'intègre correctement dans le cadre. Vous pouvez peut-être acheter aussi un couvercle de batterie supplémentaire auprès de votre concessionnaire Mondraker (pour avoir 2 batteries prêtes à l'emploi), ou bien démonter techniquement le couvercle d'origine fixé sur la batterie pour le monter sur la nouvelle. Cependant, la mousse interne n'est pas la même sur les versions 600 Wh et 800 Wh. Les anciennes batteries de 750 Wh et 625 Wh, plus lourdes, sont parfaitement compatibles avec les nouveaux modèles Scree, mais Mondraker ne fournit pas les adaptateurs nécessaires pour les monter sur ces nouveaux cadres. Le vélo peut aussi fonctionner avec le prolongateur d'autonomie Powermore et sans batterie interne, mais Bosch ne le recommande pas, et le vélo n'est pas prévu pour être utilisé uniquement avec la rallonge, comme son nom l'indique.

COMBIEN DE TEMPS FAUT-IL POUR CHARGER COMPLÈTEMENT LA BATTERIE ?

La batterie Powertube 800 Wh prend environ 6 heures pour une charge complète, tandis que la 600 Wh se charge en environ 4,5 heures lorsqu'elle est entièrement déchargée.

Si vous utilisez un prolongateur d'autonomie Powermore, celui-ci doit être rechargé séparément et nécessite environ 2,5 heures pour une charge complète.

Y A-T-IL DES INSTRUCTIONS OU CONSIGNES SPÉCIALES POUR LA BATTERIE ?

Aucune en particulier. Vous pouvez surveiller l'autonomie restante sur l'écran Kiox 400c situé sur le tube supérieur. Lorsque la charge atteint 30 %, l'assistance du moteur est légèrement réduite, et cela est encore plus perceptible en dessous de 10 %. Aucune autre recommandation spécifique.

LES DÉRAILLEURS ARRIÈRE SRAM T-TYPE DE DERNIÈRE GÉNÉRATION PEUVENT ÊTRE ALIMENTÉS DIRECTEMENT PAR LA BATTERIE PRINCIPALE DU VÉLO. EST-CE POSSIBLE SUR LES MODÈLES SCREE ?

Oui, techniquement c'est possible. Vous devrez acheter les accessoires appropriés et faire passer le câble d'alimentation par l'intérieur jusqu'à la batterie principale.

MON SCREE EST ÉQUIPÉ D'UNE TRANSMISSION SRAM T-TYPE. PUIS-JE MONTER UNE TRANSMISSION ET UN DÉRAILLEUR ARRIÈRE SHIMANO ?

Oui, tout à fait. Il vous suffira d'avoir un support de dérailleur UDH supplémentaire, adapté au dérailleur Shimano.

QUELLE EST L'ASSISTANCE MAXIMALE APPORTÉE PAR LE MOTEUR BOSCH PERFORMANCE CX DU SCREE ?

Le moteur d'origine Bosch Performance CX (BDU384Y) apporte d'origine une puissance de crête de 85 Nm et 600 W. Sur l'application Bosch Flow, vous pouvez augmenter la puissance du moteur jusqu'à 100 Nm et 750 W de puissance maximale.

EST-IL POSSIBLE DE PERSONNALISER LES MODES D'ASSISTANCE SUR SCREE ?

Vous pouvez personnaliser les modes d'assistance du moteur Bosch Performance CX du Scree de la même manière que les autres systèmes de moteurs de la gamme Bosch avec l'application Flow. Connectez-vous à l'application Flow, allumez le vélo et connectez-vous à votre Scree pour personnaliser la puissance de sortie du moteur, l'assistance initiale au pédalage via Dynamic, le maximum de km/h avec l'assistance de 25 km/h et le couple maximum de 100 Nm sur les 4 modes d'assistance : ECO, TOUR+, EMTB+ et TURBO. Vous pouvez également modifier les modes d'assistance selon vos préférences, utiliser les 4 ou moins si vous préférez.



23. FAQS

COMBIEN DE TEMPS PUIS-JE ROULER AVEC LE NOUVEAU SCREE ?

Cette question est toujours délicate et dépend également du niveau d'assistance que vous utilisez, de la condition physique du cycliste, de son poids et de ses conditions de roulement. Avec la nouvelle batterie PT800Wh, un cycliste moyen pesant 80 kg peut grimper environ 2000 m de dénivelé (1500 m avec la batterie PT600Wh) en combinant différents modes d'assistance et rouler jusqu'à 4 heures en modes ECO-TOUR+. Encore une fois, cela dépend des conditions de conduite et de la condition physique du cycliste. Le prolongateur d'autonomie PowerMore 250 Wh augmenterait l'autonomie / la distance de +30 % (avec la batterie PT800Wh) / de +40 % (avec la batterie PT600Wh) avec seulement 1,5 kg de poids en plus.

EN ROULANT AVEC LE PROLONGATEUR D'AUTONOMIE POWERMORE, QUELLE BATTERIE SE DÉCHARGE EN PREMIER, L'INTERNE OU LE PROLONGATEUR ?

Pour maintenir une puissance de sortie appropriée du moteur, les deux batteries se déchargent en même temps. Ceci est essentiel pour une bonne durée de vie de la batterie et une assistance motorisée constante. Si vous installez un PowerMore alors que votre batterie interne est presque vide, le PowerMore sera utilisé comme source d'alimentation principale jusqu'à ce que les deux charges (interne et prolongateur) soient égales, puis les deux se déchargeront de manière égale, jusqu'à ce qu'elles soient complètement vides.

QUELLES INFORMATIONS OFFRE L'ÉCRAN DU SCREE ?

Vous trouverez toutes les informations sur l'écran et le manuel de la télécommande en cliquant sur ce lien de BOSCH :

<https://www.bosch-ebike.com/en/products/kiox-400c>

JE VOUDRAIS EN SAVOIR PLUS SUR LE MOTEUR BOSCH BDU384Y PERFORMANCE CX. OÙ PUIS-JE TROUVER PLUS D'INFORMATIONS ?

Suivez ces liens de BOSCH :

<https://www.bosch-ebike.com/en/products/performance-line-cx> et <https://www.boschebike.com/en/products/performance-line-cx-r>

QUELLE MAINTENANCE OU CONTRÔLES DE SÉCURITÉ SONT NÉCESSAIRES SUR LE MOTEUR BOSCH PERFORMANCE CX ?

Absolument aucun. Il n'est pas non plus nécessaire de lubrifier les pièces de l'unité d'entraînement ni de le démonter... il vous suffit de l'entretenir comme un VTT traditionnel. Il est toutefois important de mentionner, à titre de précaution applicable à tout VTT, que les parties électroniques et, plus précisément, la zone du boîtier du pédalier de l'unité d'entraînement, ne doivent jamais être nettoyées avec une machine haute pression. Il n'est pas recommandé d'utiliser un jet d'eau sous pression pour nettoyer directement l'essieu des manivelles, car cela pourrait endommager gravement les parties électroniques de l'unité d'entraînement.

QUELLE TAILLE DE VÉLO CHOISIR ?

Les nouveaux modèles Scree 2026 ont maintenant un nouveau concept à 5 tailles avec une nouvelle taille ML, entre les tailles Medium (M) et Large (L). Par rapport à l'option habituelle de 4 tailles offerte sur d'autres modèles, ce nouveau concept s'adapte parfaitement aux exigences de tout cycliste. Consultez les tableaux des géométries pour plus d'informations et tous les détails. Voici un aperçu du dimensionnement recommandé pour une taille de cycliste donnée.

<165 cm	165-170 cm	170-175 cm	175-180 cm	180-185 cm	185-190 cm	190-195 cm	>195 cm
S		M/L			XL		
M			L				



Toutes les informations et les photos figurant sur ce document sont fournies à titre informatif uniquement et ne constituent pas un contrat juridique entre Mondraker et toute personne ou organisme. Les spécifications, les géométries ou toute autre information technique publiée sont susceptibles de changer sans préavis.

© © Toutes les marques et tous les modèles sont la propriété de Blue Factory Team, S.L.U. et sont protégés par les lois en vigueur et les accords internationaux applicables.

MANUALI E DOCUMENTI





ISTRUZIONI GENERALI DI SICUREZZA

In questo manuale tecnico vengono utilizzati i seguenti 3 simboli. Questi simboli servono per prestare attenzione alle seguenti precauzioni:

PERICOLO:

Non seguire le indicazioni o utilizzare la bicicletta in modo improprio poiché potrebbero causare lesioni gravi o letali. Queste mansioni comportano difficoltà tecniche e, se sono eseguite male, potrebbero danneggiare la bicicletta o comportare l'annullamento della garanzia.

ATTENZIONE!

Non seguire le indicazioni o utilizzare la bicicletta in modo improprio può causare lesioni lievi. Queste mansioni comportano difficoltà tecniche e, se sono eseguite male, potrebbero danneggiare la bicicletta o comportare l'annullamento della garanzia.

INFORMAZIONI

Informazioni indispensabili per una corretta esecuzione dei procedimenti per evitare eventuali danni della bicicletta o perdita della garanzia, ma che non comportano alcun rischio per la persona.

ALTRE CONSIDERAZIONI

- L'uso di ricambi non originali può causare danni, malfunzionamenti e incidenti che possono portare a gravi conseguenze.
- Per eseguire i passaggi descritti in questo manuale, sono richieste competenze che vanno ben oltre le conoscenze di un'utilizzatore medio di bicicletta. Nel caso in cui non si è qualificati per seguire una delle seguenti indicazioni, si prega di portare la bicicletta presso un servizio tecnico autorizzato Mondraker per la manutenzione e la sostituzione dei suoi componenti. L'installazione errata dei pezzi di ricambio può causare malfunzionamenti, incidenti, lesioni e l'annullamento della garanzia.

PULIZIA E CURA

- Non appena i pezzi sono stati smontati, si consiglia di pulire, ingrassare e mettere il frenafili (se necessario) sui componenti che verranno riutilizzati.

LEGENDA DEI SIMBOLI



Fissatore per filettature di grado medio. Loctite 243 o simile.



Grasso sintetico di qualità per il montaggio.



Grasso speciale carbonio per creare attriti.

1. GEOMETRIA

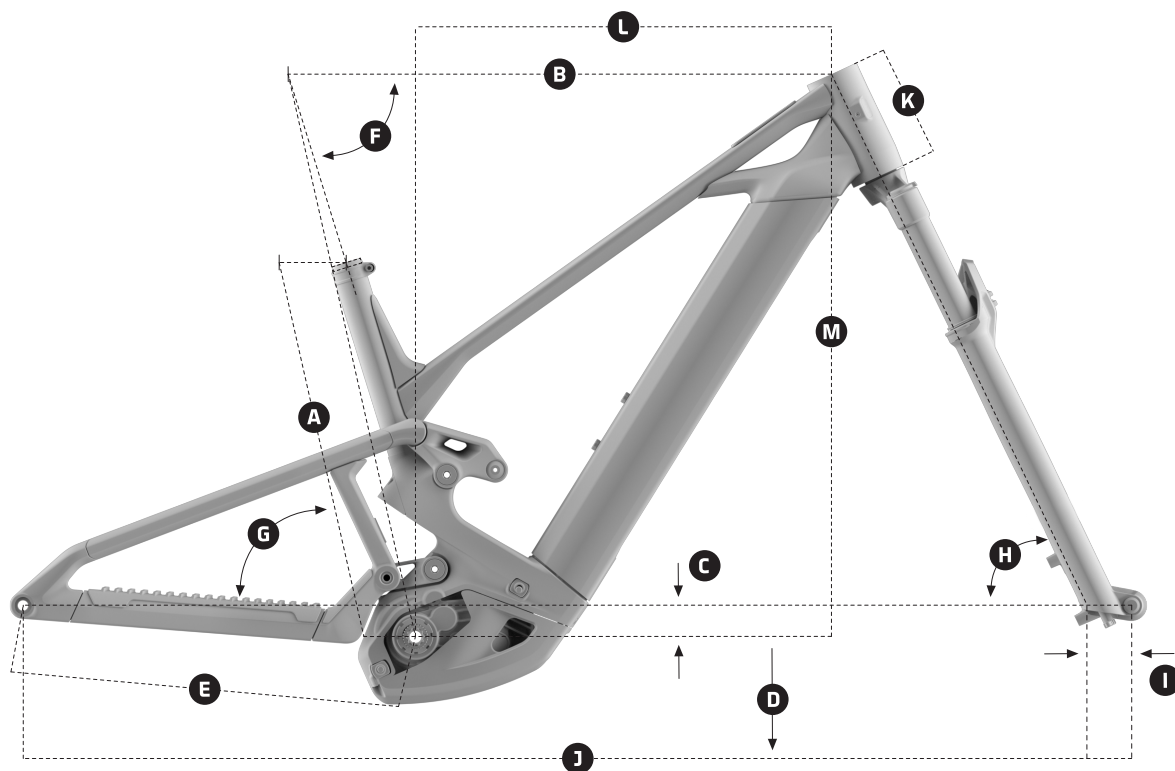

SCREE

DIMENSIONE DEL TELAIO	S	M	ML	L	XL
A Lunghezza Piantone	380 mm	410 mm	435 mm	460 mm	490 mm
B Lunghezza Tubo Orizz. Virtuale	587,6 mm	607,6 mm	628,8 mm	650,7 mm	672,8 mm
C BB Drop	-35 mm	-35 mm	-35 mm	-35 mm	-35 mm
D Altezza movimento centrale	340 mm	340 mm	340 mm	340 mm	340 mm
E Lunghezza Batticatena	456 mm	456 mm	456 mm	456 mm	456 mm
F Angolo tubo sella	74°	74°	74°	74°	74°
G Angolo Sella	77°	77°	77°	77°	77°
H Angolo Sterzo	65,5°	65,5°	65,5°	65,5°	65,5°
I Offset Forcella / Rake	44 mm	44 mm	44 mm	44 mm	44 mm
J Interasse	1221,2 mm	1241,2 mm	1263,3 mm	1287,4 mm	1311,5 mm
K Lunghezza Tubo Sterzo	125 mm	125 mm	130 mm	140 mm	150 mm
L Reach	440 mm	460 mm	480 mm	500 mm	520 mm
M Stack	644,6 mm	644,6 mm	649,2 mm	658,3 mm	667,4 mm



2. SPECIFICHE DEL TELAIO DELLA BICICLETTA

TAGLIE TELAIO	S / M / ML / L / XL
DIMENSIONE RUOTA ANTERIORE	29"
MOZZO ANTERIORE	110mm x 15mm (BOOST)
DIMENSIONE RUOTA POSTERIORE	29"
MOZZO POSTERIORE	148mm x 12mm (BOOST)
ASSE POSTERIORE	12X148 P1.0 L180
ATTACCHI PORTABORRACCE / RANGE EXTENDER	2 POSIZIONI, 1 PORTABORRACCE / RANGE EXTENDER
MOTORE	BOSCH PERFORMANCE LINE CX
MOVIMENTO CENTRALE	BOSCH
BATTERIA	800Wh / 600Wh
RANGE EXTENDER	BOSCH POWERMORE 250Wh
ESCURSIONE POSTERIORE	130mm
AMMORTIZZATORI POSTERIORI	165 x 45mm TRUNNION, 30 x 8mm
ESCURSIONE ANTERIORE	150mm
DIAMETRO REGGISELLA	31.6mm / 34.9mm
LINEA CATENA	55mm
STERZO	ZS56 / ZS56, 1-1/8", 1.5"
DIMENSIONE CORONA MASSIMA	34T
FRENO POSTERIORE	POST MOUNT, DIRECT 220mm max
DIMENSIONE MASSIMA RUOTA COMPATIBILE	29" x 2.6" (66-622)

3. PROFONDITÀ INSERIMENTO REGGISELLA

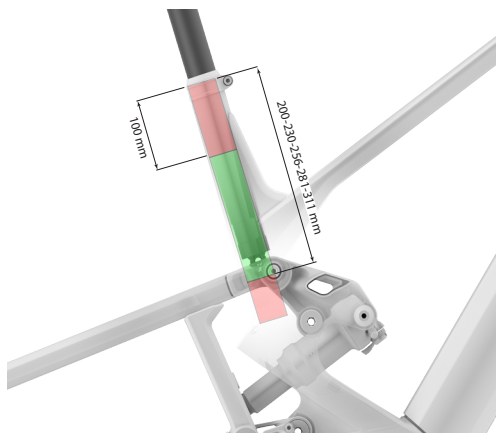

TAGLIA TELAIO	MIN. (mm)	MAX. (mm)
XL	100	311
L	100	281
ML	100	256
M	100	230
S	100	200



4. COMPONENTI TRASMISSIONE

4.1. GUIDA CATENA

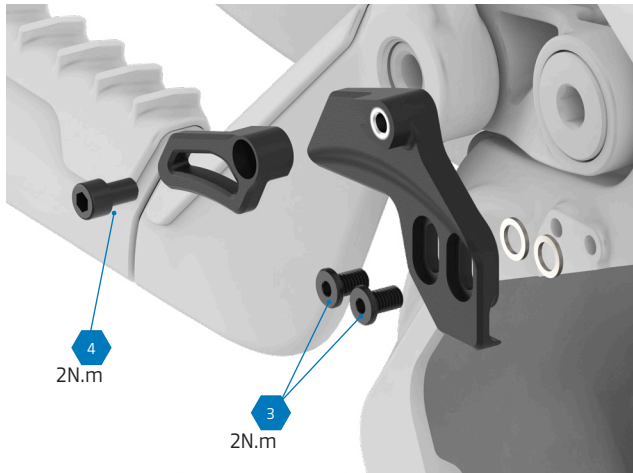

4.2. GUARNITURA



Consultare il manuale del produttore della corona per sapere se è compatibile con un O-ring.

5. COPERCHIO MOTORE

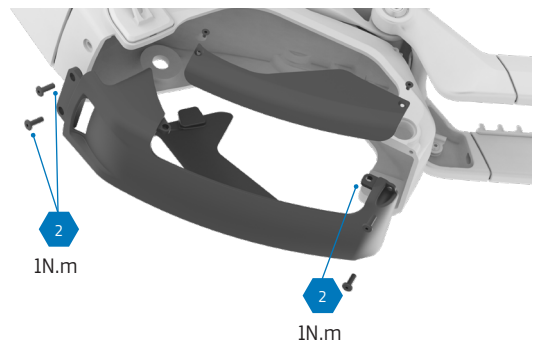
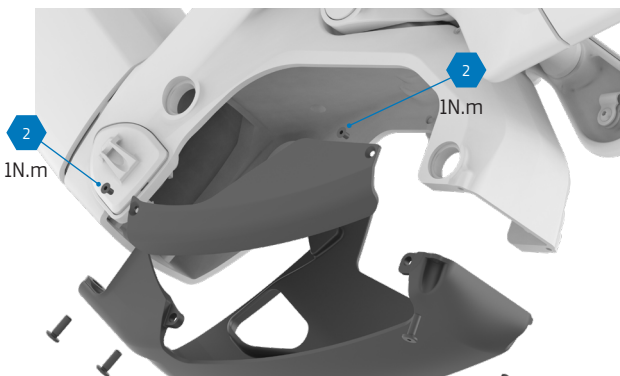



6. RIMOZIONE MOTORE



Non usare Loctite 243

6.1. CONNESSIONI DEL MOTORE

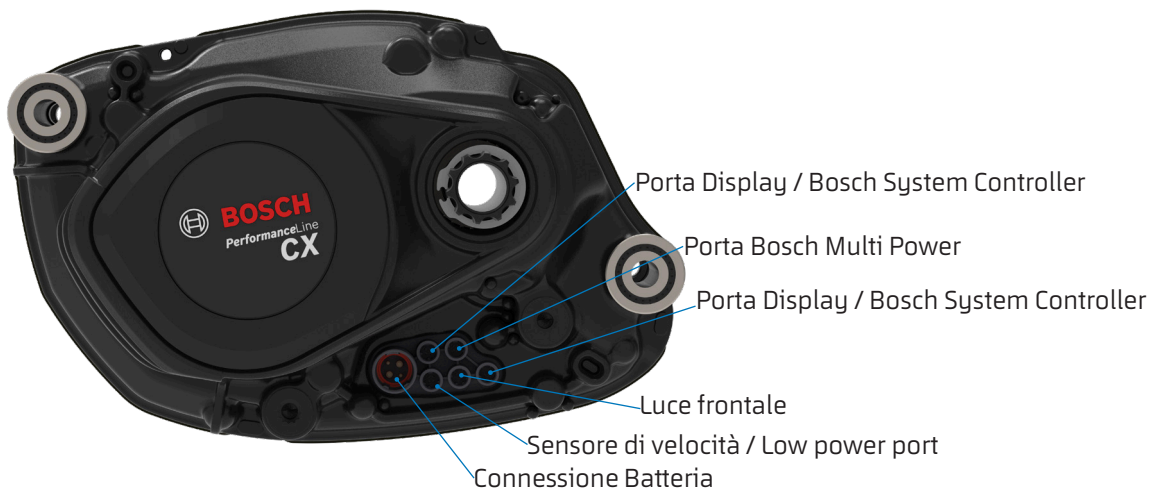

CONNESSIONE PORTA DI RICARICA

CONNESSIONE BATTERIA



7. PORTA DI RICARICA

7.1. RIMUOVERE PORTA DI RICARICA

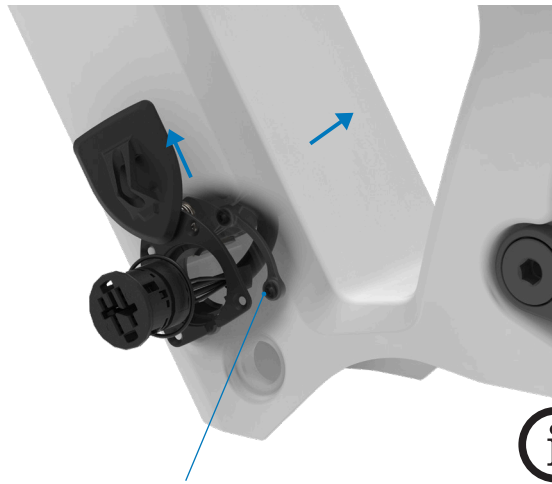
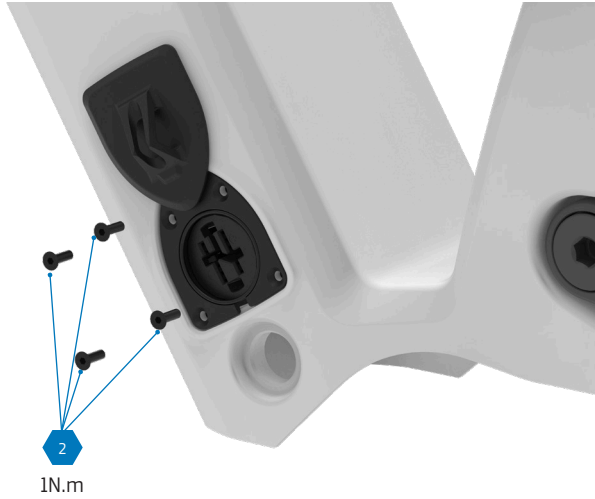

Rimuovere il coperchio lateralmente



Le 2 basi metalliche
escono dall'interno
del tubo diagonale



8. RIMOZIONE DELLA BATTERIA

1° STEP

Svitare la prima sezione filettata. La batteria uscirà ma rimarrà attaccata alla struttura.

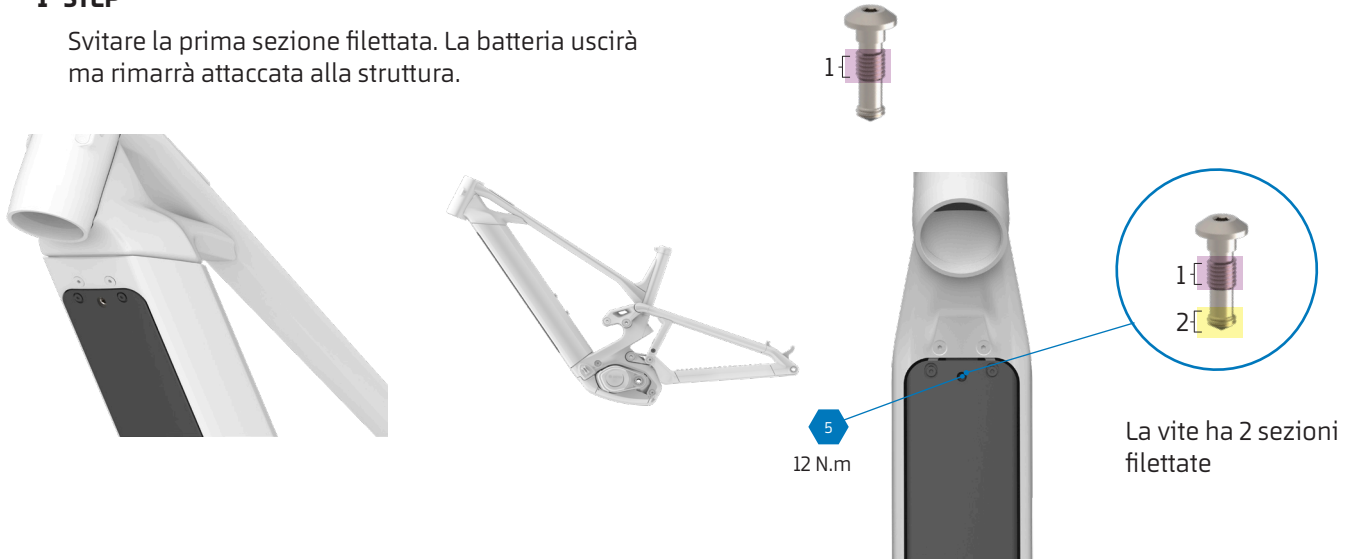

FINE DEL 1° STEP

A questo punto, tieni la batteria con una mano e continua a svitare la seconda sezione della vite filettata.

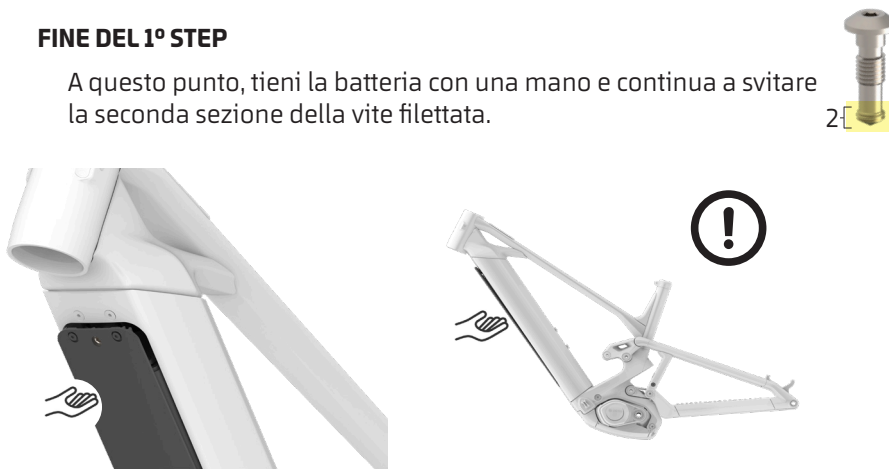

2° STEP

La batteria uscirà completamente dalla sede. Attenzione, la batteria è pesante. Si raccomanda di tenerla ben salda per evitare che possa cadere a terra e danneggiarsi in modo permanente.

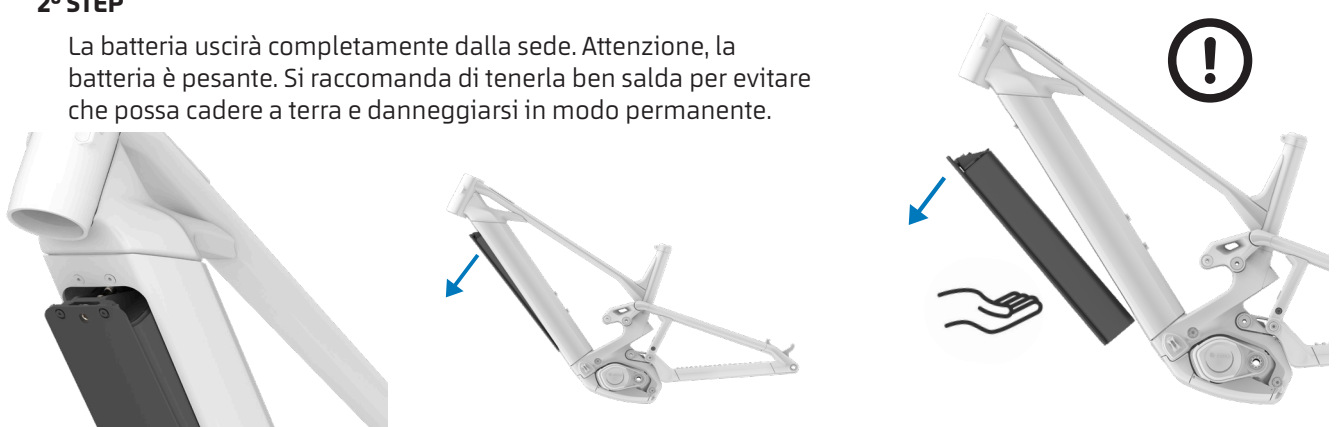



9. GUIDA INTERNA CAVI

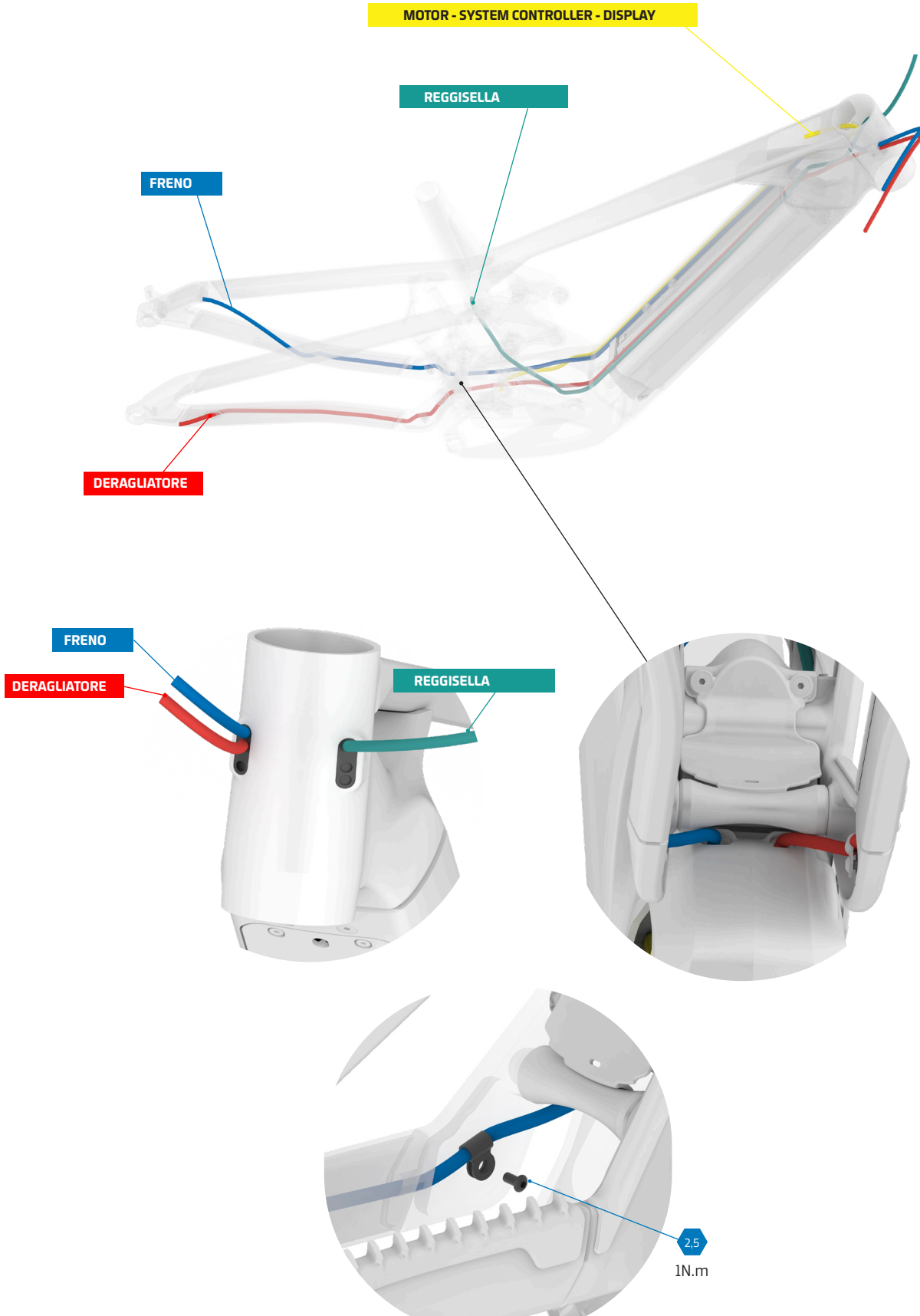



10. ANCORAGGIO DELLA BATTERIA

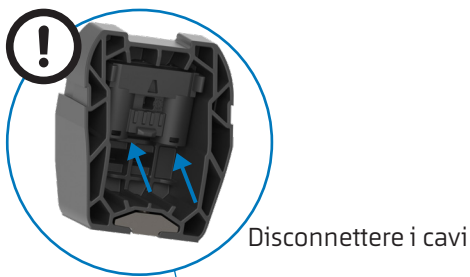
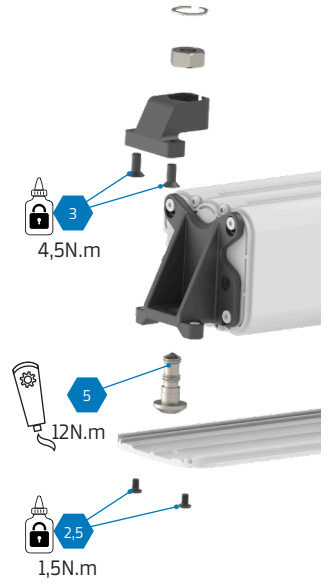
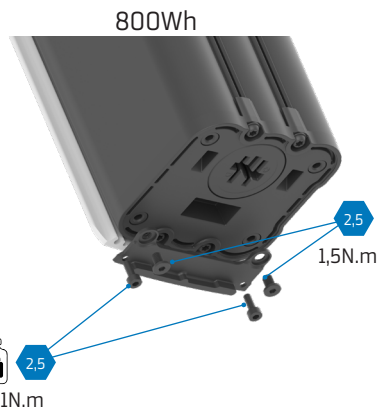
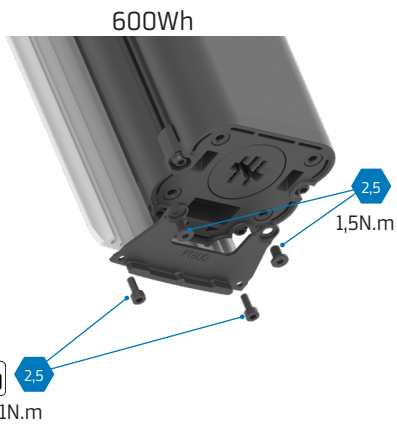
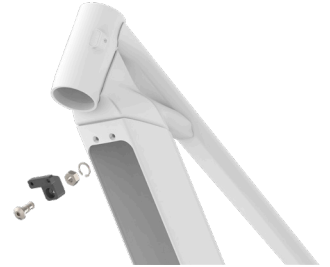
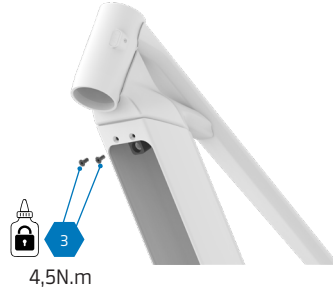



11. CONVERSIONE DELLA BATTERIA 600 WH / 800 WH

11.1 INSTALLAZIONE DEGLI ELEMENTI DI FISSAGGIO DELLA BATTERIA

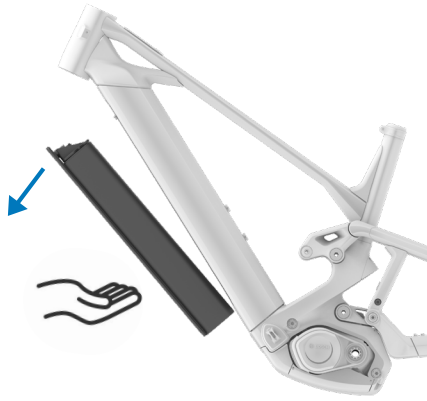

600Wh



800Wh

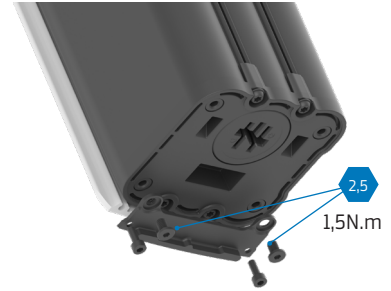

600Wh

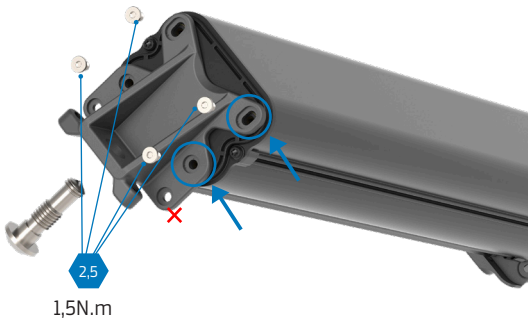

800Wh

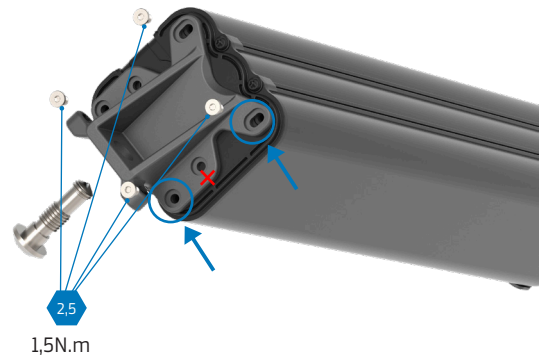



11. CONVERSIONE DELLA BATTERIA 600 WH / 800 WH

11.2. INSTALLAZIONE DEL COPERCHIO DELLA BATTERIA

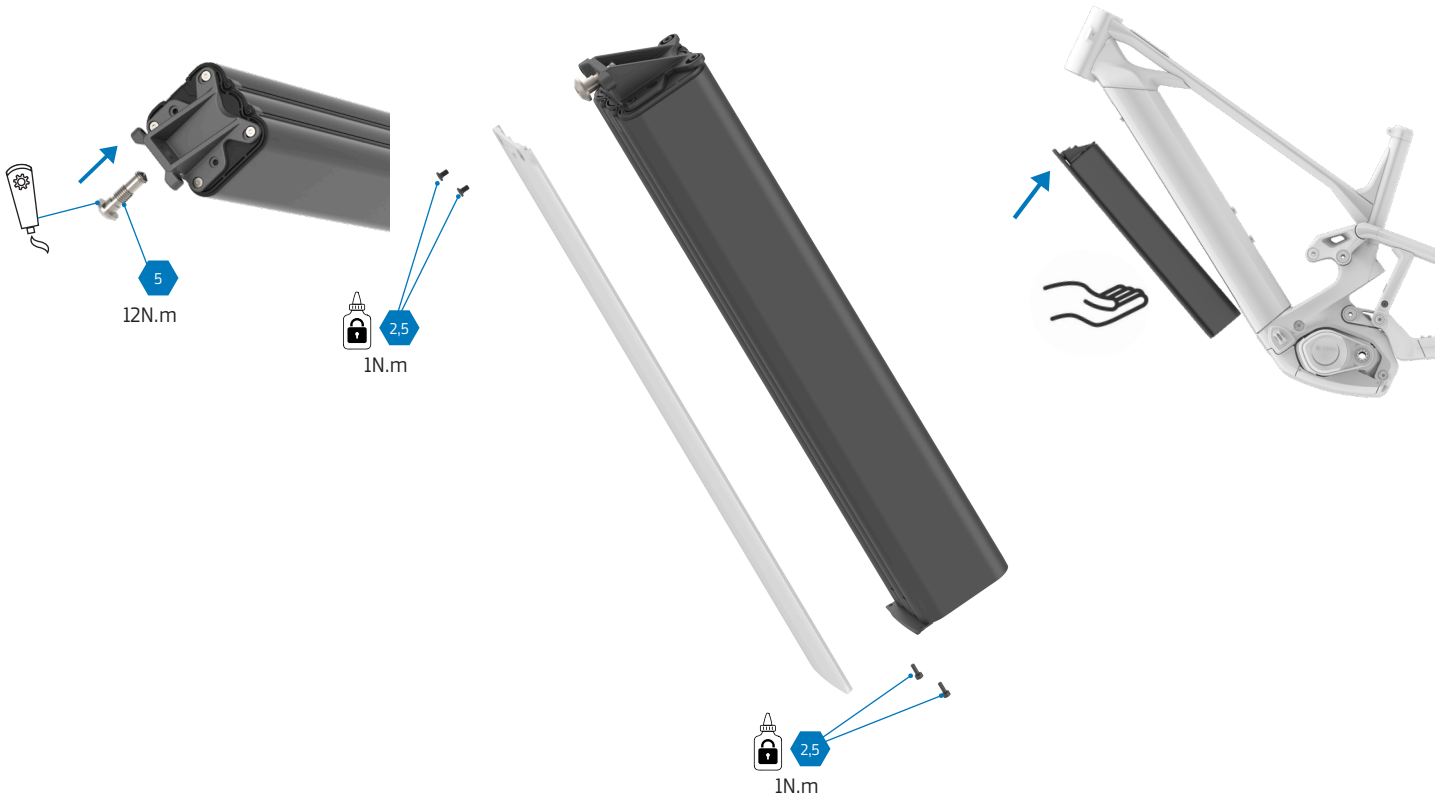

8. 4. NUMERO DI RIFERIMENTO



SUPPORTO
ANTERIORE BATTERIA
800Wh/600Wh
Ref. 099.25049



SUPPORTO POSTERIORE
BATTERIA 800Wh
Ref. 099.26020



SUPPORTO POSTERIORE
BATTERIA 600Wh
Ref. 099.26021



8. 5. PARTI DI RICAMBIO NECESSARIE PER UNA SECONDA BATTERIA

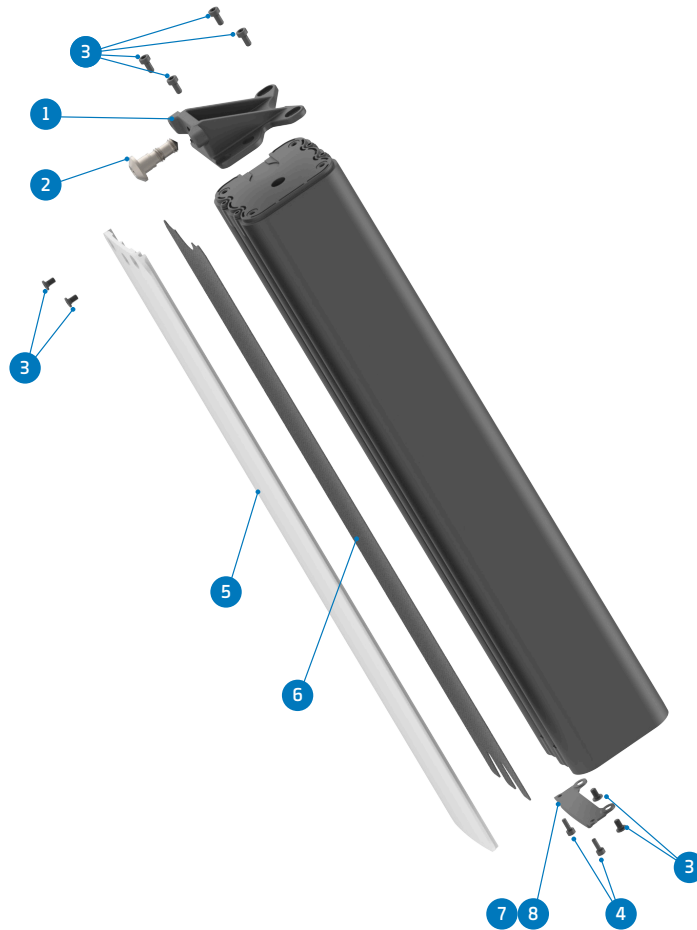

ITEM	DESCRIPTION	QTY.	PART NUMBER
1	BATTERY MOUNT BRACKET FRONT	1	099.25049
2	BATTERY RELEASE SCREW	1	099.25051
3	SCREW BOLT M4X6	8	099.25052
4	SCREW BOLT M4X8	2	099.12116
5	BATTERY COVER	1	Refer to B2B web for color options
6	FOAM FOR BATTERY COVER	1	099.25089
Choose between:			
7	BATTERY HOLDER REAR 800Wh (only for 800Wh battery)	1	099.26020
8	BATTERY HOLDER REAR 600Wh (only for 600Wh battery)	1	099.26021
9	FOAM FOR 600Wh BATTERY (only 600wh battery)	1	099.25097



SUPPORTO POSTERIORE
BATTERIA 800Wh
Ref. 099.26020

SUPPORTO POSTERIORE
BATTERIA 600Wh
Ref. 099.26021



9. SCHIUMA

9.1. INSTALLAZIONE DEL FOGLIO DI SCHIUMA PER IL TELAIO

Ref. 099.25088



10. BOSCH SYSTEM CONTROLLER KIOX 400

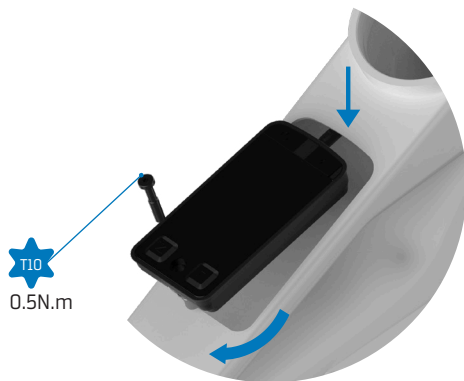

11. BOSCH MINI REMOTE



12. CHAINSTAY PROTECTOR



Le protezioni dei foderi sono prive di foro per deragliatori meccanici o con cavo. Sul retro è presente un segno per forare l'uscita del cavo.

Per un risultato ottimale, si consiglia l'utilizzo di pinze di foratura.



13. RANGE EXTENDER BOSCH POWERMORE KIT

EU28, CH, NO, AUS, NZ

POWERMORE 250 KIT (BBP3620 EU28,CH,NO,AUS,NZ)
incl. battery holder, bottle holder, screws, IBD packaging
EB12.100.05G

US, CANADA

POWERMORE 250 KIT (BBP3625 US, CAN) incl.
battery holder, bottle holder, screws, IBD packaging
EB12.100.05H



CABLE POWERMORE 150MM (BCH3923_150) **EB12.120.036**



14. PARAFANGHI

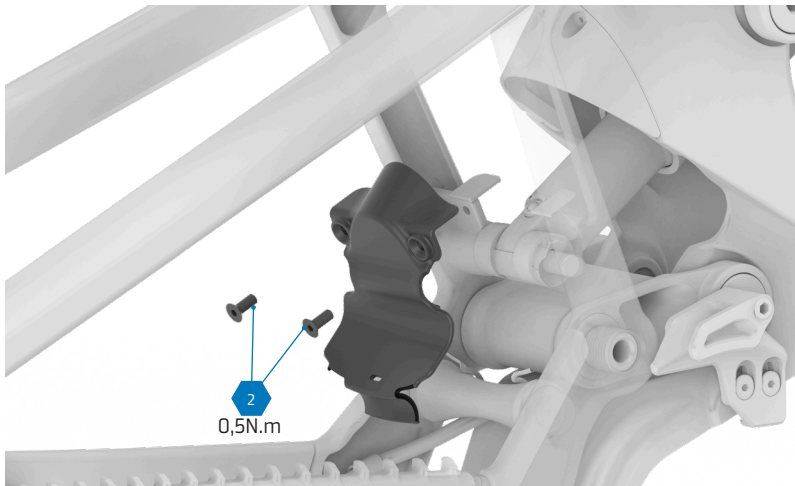
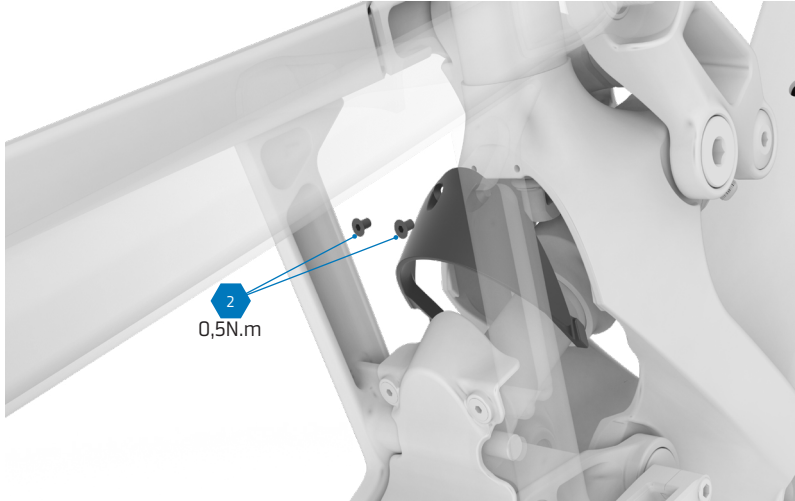

15. COLLARINO SELLA

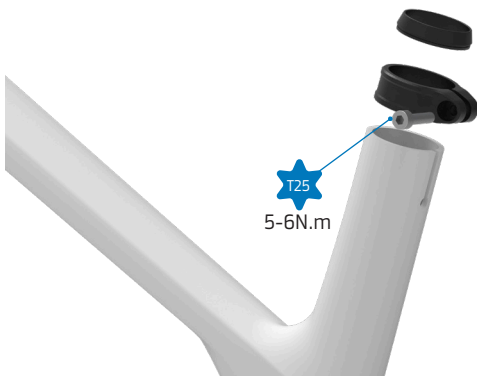

Si raccomanda di utilizzare grasso a frizione per carbonio sul reggisella



16. GUIDA ALL'INSTALLAZIONE DEL LEVERAGGIO SUPERIORE

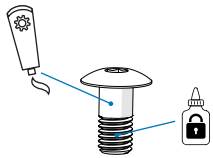
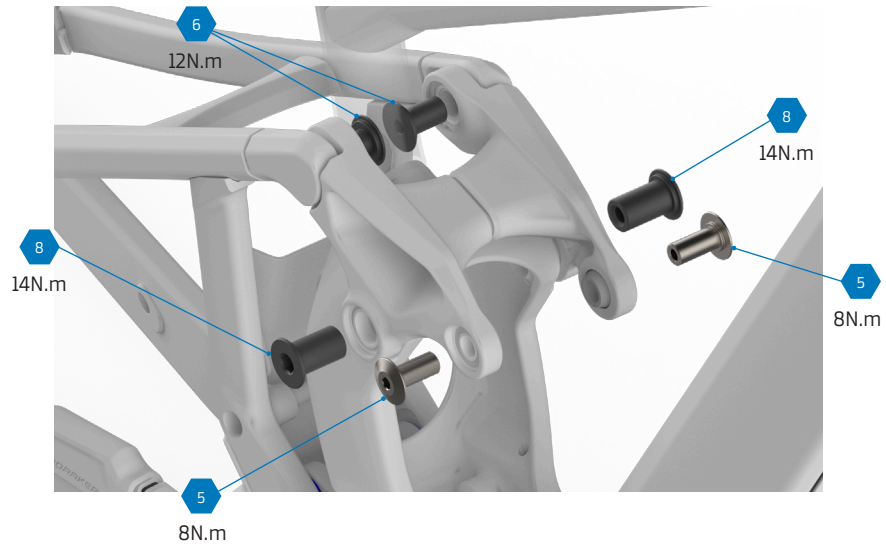

Per le viti principali applicare grasso all'albero e Loctite 243 o simile alle filettature.

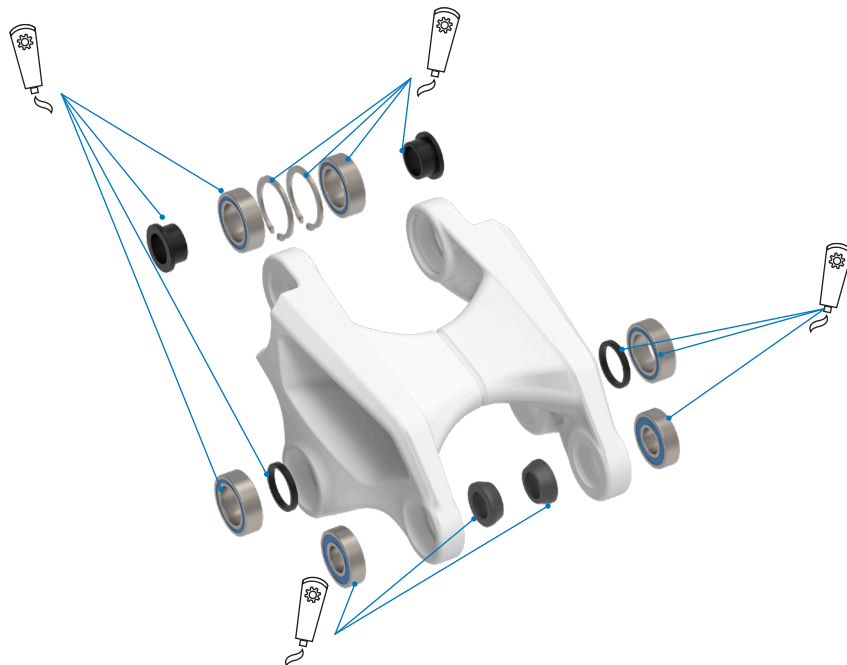

Applica grasso.



17. GUIDA ALL'INSTALLAZIONE DELLA BIELLETTA INFERIORE

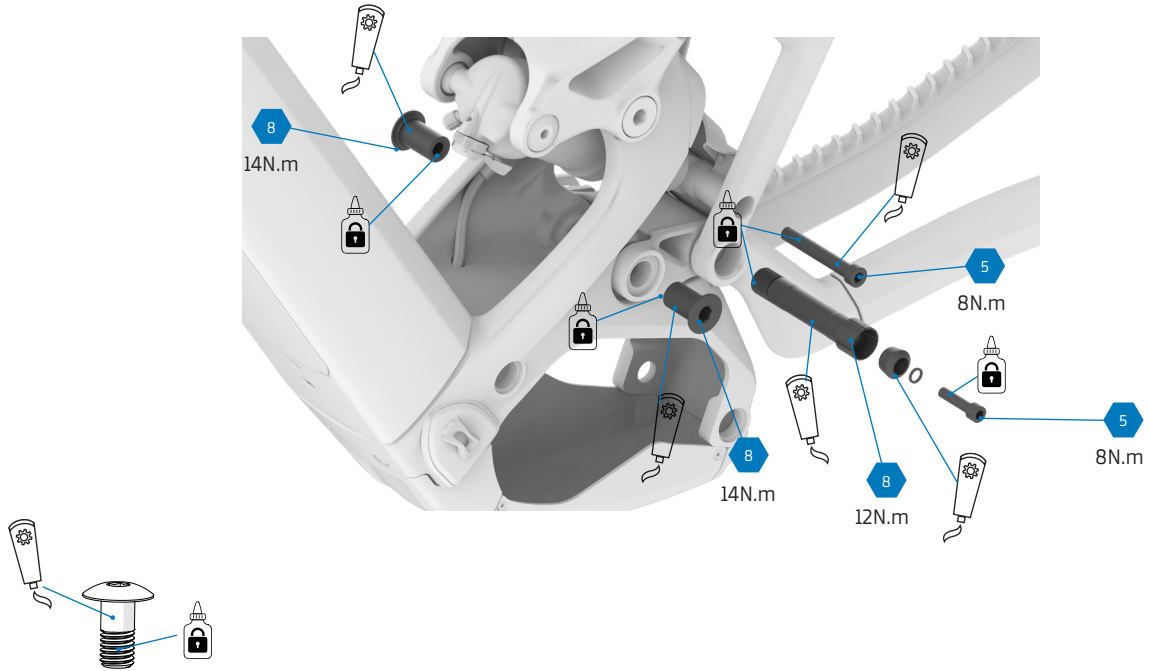

Per le viti principali applicare grasso all'albero e Loctite 243 o simile alle filettature.



Applicare grasso

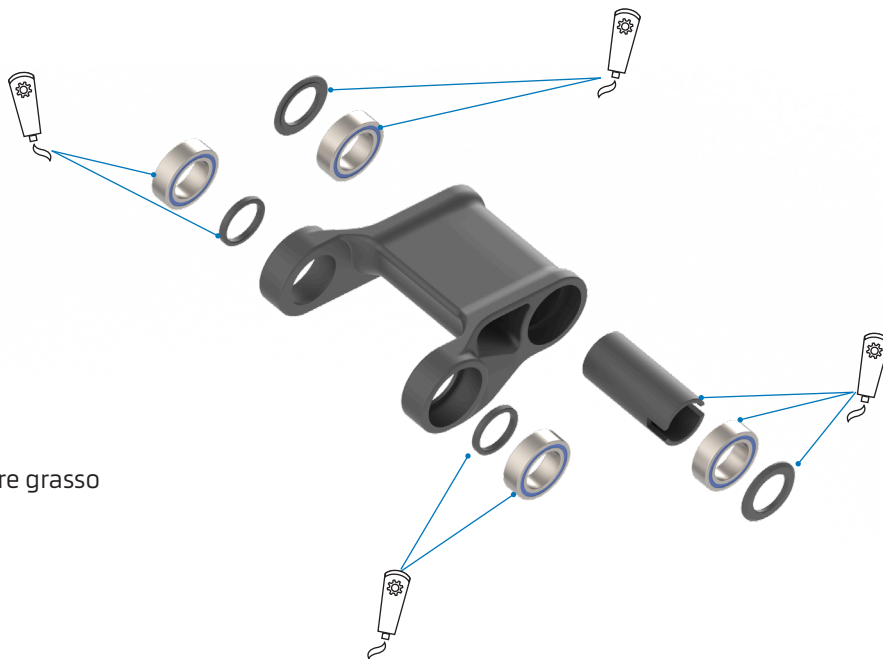



19. CONNESSIONE A UNO SMARTPHONE



eBike Flow app



Accendi la bici.
Una volta accesa, premere per 5 secondi il pulsante Power fino a quando un LED blu inizia a lampeggiare.
A questo punto apri l'app eBike Flow e segui le istruzioni sul tuo telefono per effettuare l'abbinamento.

20. MONTAGGIO DELL'ATTACCO MANUBRIO

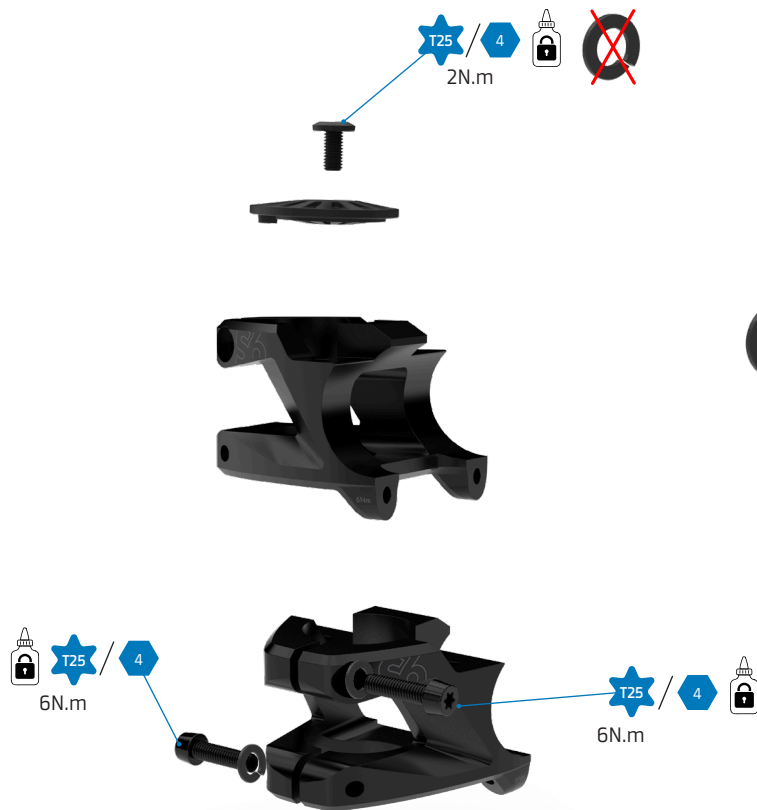

Le 6 viti dell'attacco manubrio, ad eccezione di quella del tappo della serie sterzo, devono essere dotate di una rondella spaccata

1. Inserimento dell'attacco manubrio

Fai scorrere il corpo dell'attacco manubrio sul canotto di sterzo della forcella fino a farlo posizionare correttamente.

2. Regolazione della serie sterzo (Precarico)

Posiziona il tappo superiore della serie sterzo (top cap) e la relativa vite. Stringi la vite superiore a una coppia massima di 1 Nm per precaricare i cuscinetti ed eliminare qualsiasi gioco nello sterzo.

3. Serraggio delle viti laterali

Allinea l'attacco manubrio con la ruota anteriore. Stringi le viti laterali di fissaggio in modo graduale e alternato per distribuire il carico. Aumenta la tensione progressivamente (ad es., la superiore a 4 Nm, l'inferiore a 4 Nm, poi entrambe a 5 Nm) fino a quando le due viti raggiungono l'esatta coppia di serraggio finale di 6 Nm.

Consiglio di montaggio:

È più facile allineare visivamente l'attacco manubrio con la ruota anteriore se il manubrio è già installato. A tal fine, esegui questo passaggio applicando solo una leggera tensione alle viti laterali, procedi al Montaggio del manubrio (Sezione 2), esegui l'allineamento finale dell'intero gruppo e, per ultimo, applica la coppia di serraggio definitiva di 6 Nm alle viti laterali della forcella.

21. MONTAGGIO DEL MANUBRIO

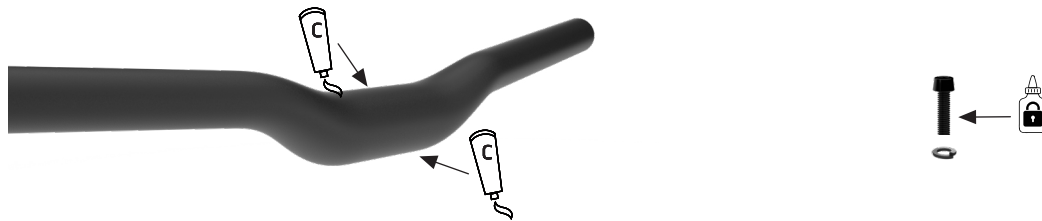

Applica un sottile strato di pasta di montaggio specifica per carbonio sulla zona di contatto tra il manubrio e l'attacco manubrio. Se le filettature delle viti sono asciutte, applica una piccola goccia LOCTITE 243.

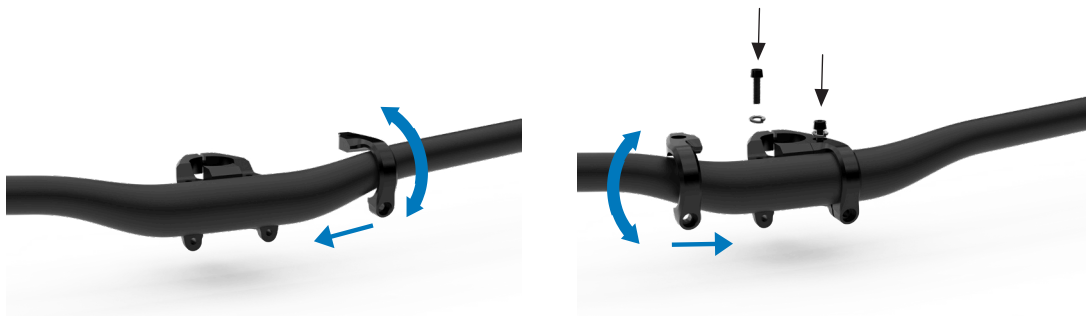

Fai scorrere la piastra frontale dell'attacco manubrio dalla parte più stretta del manubrio verso il centro, facendo attenzione a non graffiare la superficie del componente. Regolala e inserisci la vite superiore per tenerla in posizione. Non stringere alla coppia finale.



Inserisci le due viti superiori e avvitalo di qualche giro a mano senza applicare la coppia di serraggio finale. Successivamente, inserisci le due viti inferiori senza stringerle.

Nota: Se risulta difficile allineare o avvitare le viti inferiori, allenta leggermente quelle superiori per facilitare l'inserimento e riprova.



21. MONTAGGIO DEL MANUBRIO

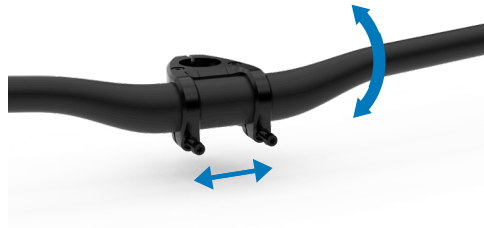

Regola la rotazione e il centraggio del manubrio fino a raggiungere la posizione desiderata.

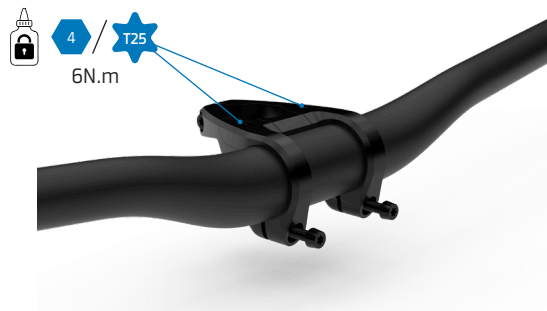

Stringi le viti superiori in modo graduale, alternando i lati. Aumenta la tensione progressivamente (ad es., 4 Nm, poi 5 Nm su ciascun lato) fino a raggiungere l'esatta coppia di serraggio finale di 6 Nm. È di vitale importanza che entrambe le viti superiori siano completamente fissate a 6 Nm in questa fase.

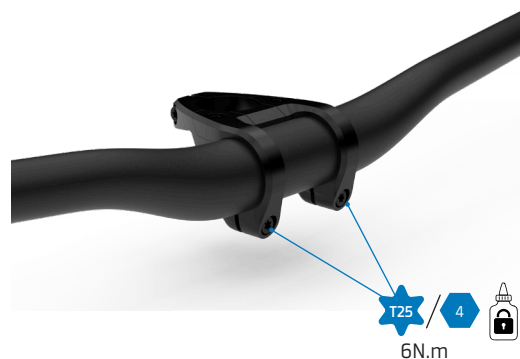

Con il manubrio nella sua posizione definitiva, stringi le viti inferiori in modo graduale e alternando il lato sinistro e il destro (4 Nm, 5 Nm e infine 6 Nm) per distribuire il carico uniformemente.

Verifica visivamente il corretto accoppiamento dell'attacco manubrio. Per progettazione, non deve esserci alcuno spazio tra i componenti nella parte superiore; la luce di serraggio deve rimanere esclusivamente nella parte inferiore. Infine, controlla con la chiave dinamometrica che tutte e quattro le viti mantengano la coppia specificata di 6 Nm. Rimuovi inoltre l'eventuale grasso in eccesso.



22. SPARE PARTS
SCREE



DETAIL 01

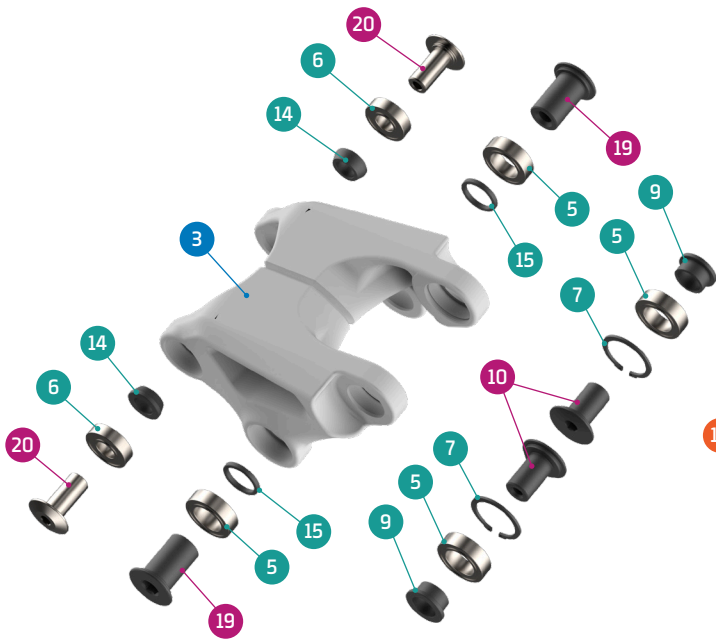

DETAIL 02

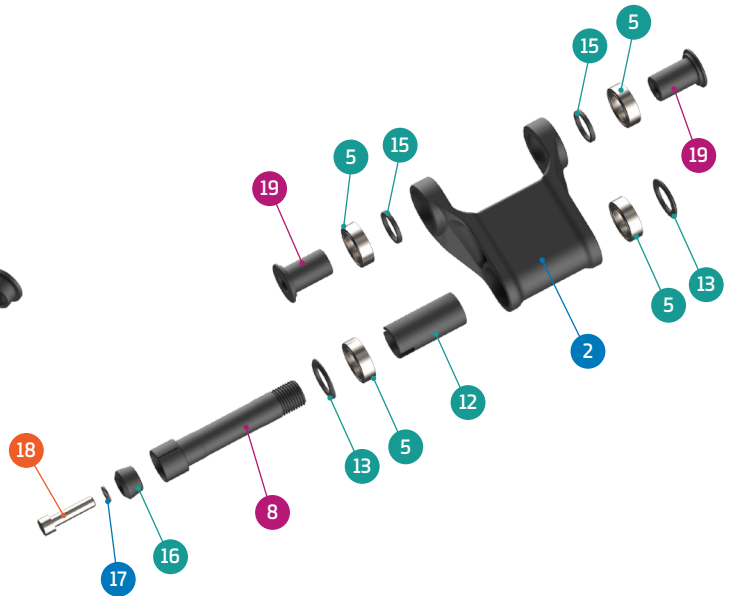

FOAM FOR BATTERY (600WH)

FOAM FOR MAIN TUBE

FOAM FOR BATTERY COVER

SET 7

SET 6

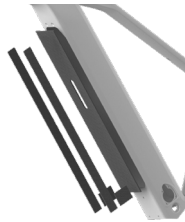

CABLE GUIDE KIT

DISC ADAPTOR KIT

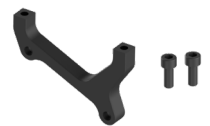

SET 1

SET 2

SET 3

SET 4

SET 5

ZERO BEARING KIT 26

SHOCK HARDWARE KIT 22

UPPER LINK KIT 30

LOWER LINK KIT 37

CHAIN GUIDE PLATE + BOLTS

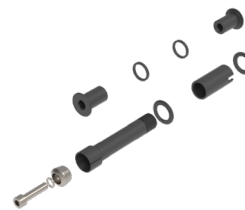

PART NUMBER	DESCRIPTION	COMPONENTS
099.22101	SET 1: ZERO BEARING KIT 26	BEARING 3802-2RS, 24x15x7 (x8) / BEARING 6900V-2RS, 10x22x6 (x2)
099.24200	SET 2: SHOCK HARDWARE KIT 22	SPACER (x2) / SHOCK BOLT (x2) / SHOCK BOLT (x1)
099.22300	SET 3: UPPER LINK KIT 30	SPACER, 15x19x2.5T (x2) / UPPER LINK-RT SPACER (x2) / PIVOT AXLE, M12 (x2) / PIVOT AXLE, M15 (x2) / C-RING (x6)
099.25400	SET 4: LOWER LINK KIT 37	SPACER, 15x27x2 (x2) / SPACER, 15x19x2.5t (x2) / INNER LOWER LINK SPACER (x1) / PIVOT AXLE, M10 (x1) / AXLE NUT, M10 (x1) / MAIN AXLE (x1) / SPACER (x1) / TAPER NUT (x1) / SCREW BOLT (x1)
099.24018	SET 5: CHAIN GUIDE PLATE + BOLTS	CHAIN GUIDE BASE (x1) / CHAIN GUIDE OUTER PLATE (x1) / SCREW BOLT, M5x12 (x2) / SCREW BOLT, M5x8 (x1) / WASHER 5x9x1t (x4)
099.25018	SET 6: DISC ADAPTOR KIT	DISC ADAPTOR (x1) / SCREW BOLT (x2)
099.25013	SET 7: CABLE GUIDE KIT	CABLE GUIDE (x1) / SCREW BOTL M2.5X5L (x1) / SCREW BOLT M3X10L (x1)
099.25088	FOAM KIT FOR MAIN TUBE	
099.25089	FOAM FOR BATTERY COVER	
099.25097	FOAM FOR 600Wh BATTERY	



23. FAQs

QUAL È LA DIFFERENZA TRA LA NUOVA SCREE E LA CRAFTY CARBON?

Sia Scree che Crafty Carbon sono le eMTB più versatili di Mondraker, ma ognuna ha un utilizzo previsto differente, con telai, cinematica, geometria ed escursioni diverse.

Scree è un modello Trail completamente nuovo, con 130 mm di escursione posteriore e 150 mm anteriore, costruito con telaio in lega Stealth. Crafty Carbon è un modello Enduro, con 150 mm di escursione posteriore e 160 mm anteriore, dotato di telaio Stealth Air Carbon. Entrambe montano il nuovo motore Bosch Performance CX Gen 5 e batterie da 600 Wh o 800 Wh. Entrambe sono disponibili in 5 taglie, ognuna con geometria dedicata, e utilizzano l'ultima generazione del motore Bosch Performance CX con fino a 100 Nm e 750W, compatibile con batterie da 800 Wh e 600 Wh per la migliore esperienza di guida.

QUANTO PESA IL TELAIO DELLA NUOVA SCREE?

Il telaio Scree verniciato, completo di ferramenta e accessori ma senza ammortizzatore posteriore, in taglia ML pesa circa 4,900 kg.

QUANTO È PIÙ LEGGERA LA BATTERIA DA 600WH RISPETTO A QUELLA DA 800WH?

La Powertube 800Wh pesa 3.990 grammi, mentre la nuova Powertube 600Wh pesa 3.070 grammi. Entrambe utilizzano celle di ultima generazione 21700.

QUALI AMMORTIZZATORI SONO COMPATIBILI CON LA NUOVA SCREE?

Scree è compatibile con qualsiasi ammortizzatore inline ed è stata ottimizzata per funzionare al meglio con questi modelli. È possibile utilizzare anche modelli con piggyback come la serie Float X o RockShox SuperDeluxe. Per modelli con volume maggiore è obbligatorio verificare la compatibilità, poiché potrebbero non entrare. La Scree utilizza ammortizzatori metrici 165x45 mm con attacco superiore Trunnion e hardware inferiore standard 30x8 mm.

QUALI CARATTERISTICHE CINEMATICHE OFFRE LA NUOVA SCREE?

Il design e la configurazione della sospensione Zero sono stati aggiornati e migliorati seguendo le più recenti evoluzioni prestazionali viste sugli altri modelli full suspension di ultima generazione di Mondraker, in questo caso ottimizzati per un utilizzo Trail versatile. La Scree presenta una progressione del 20,5%, un rapporto di leva più alto che rende la sospensione più morbida e sensibile nelle prime fasi di compressione, curve di anti-squat e anti-rise leggermente più basse per una sospensione posteriore più performante e complessivamente più efficace.

QUAL È LA MASSIMA ESCURSIONE DELLA FORCELLA SULLA NUOVA SCREE?

Scree è compatibile con forcelle fino a 160 mm di escursione o 580 mm asse-corona.

È POSSIBILE MONTARE UN DISCO FRENO POSTERIORE MAGGIORE DA 220MM SULLA SCREE?

Sì, Scree è compatibile con disco freno posteriore da 220 mm posteriori. Non è particolarmente consigliato, ma è possibile come sui modelli Crafty Carbon.

QUAL È LA MASSIMA SEZIONE DI PNEUMATICO CHE LA SCREE PUÒ ACCOGLIERE?

Scree è compatibile con pneumatici fino a 66 mm di larghezza, equivalenti a 29"x 2,6".

Si consiglia di misurare lo pneumatico prima del montaggio poiché la larghezza reale può variare a seconda del produttore.



23. FAQs

SCREE È COMPATIBILE CON UNA RUOTA POSTERIORE DA 27,5"?

Tecnicamente sì è possibile utilizzare una ruota posteriore più piccola da 27,5", ma la bici non è progettata per configurazioni mullet e il motore non funzionerebbe in modo ottimale quando il diametro della ruota viene modificato. La diversa circonferenza influirebbe sulla lettura della velocità e non può essere regolata. Per esempio, passare a una combinazione di ruota e pneumatico posteriore da 27,5x2,6" ridurrebbe la velocità di cut-off di circa 1-2 km/h, e probabilmente, con il sensore di velocità a magnete sulla ruota posteriore di diametro più piccolo, il motore potrebbe non funzionare correttamente. Anche la geometria di Scree verrà compromessa, con gli angoli che cambieranno di -1,5° e il movimento centrale che si abbasserà di -13/-15 mm, cosa ancora più importante, Mondraker non copre la garanzia se non si utilizza la ruota posteriore da 29" originale.

È POSSIBILE AGGIUNGERE UN RANGE EXTENDER PER AUMENTARE L'AUTONOMIA E PEDALARE PIÙ A LUNGO?

Sì, come su qualsiasi degli ultimi sistemi motore Bosch, è disponibile un Bosch Powermore da 250 Wh in stile "borraccia". Pesa 1.450 g o 1.525 g inclusi il supporto di montaggio laterale specifico Bosch e il cavo di collegamento.

Potrai beneficiare di una maggiore autonomia rispetto alle batterie Powertube Interne da 600 Wh (+40%) o 800 Wh (+30%).

QUALI CONSIDERAZIONI IMPORTANTI DOVREI TENERE A MENTE QUANDO INSTALLO IL POWERMORE?

Bosch offre diverse lunghezze del cavo di collegamento per il range extender Powermore; per tutti i modelli e le taglie dalla Scree sarà necessaria la versione da 150 mm. Il codice prodotto è: BCH3923_150 / EB12.120.036. È anche importante notare che esistono due tipi Powermore da considerare a seconda del Paese in cui vivi: PowerMore, EU28, CH, NO, AUS, NZ (Codice prodotto Bosch BBP3620 / EB12.100.05G) e US, CAN, KOR (Codice prodotto Bosch BBP3625 / EB12.100.05H)

POSSO MONTARE UNA BORRACCIA?

Sì, è possibile. Ci sono due posizioni disponibili per il portaborraccia: nel telaio principale, nella posizione standard come su qualsiasi altra bici, e sotto il tubo orizzontale.

IL PASSAGGIO DEI CAVI È ESTERNO AI LATI DEL TUBO DI STERZO. È POSSIBILE FAR PASSARE I CAVI INTERNAMENTE ATTRAVERSO IL HEADSET COME SU ALTRI MODELLI?

Sì, è possibile. La nuova calotta superiore del headset è predisposta per instradare i cavi al suo interno e permettere il passaggio completamente interno, se preferisci questa soluzione.

È POSSIBILE RIMUOVERE LA BATTERIA INTERNA?

Sì. La nuova Scree permette di rimuovere facilmente la batteria interna. È molto semplice: basta svitare il bullone superiore da 5 mm esagonale nella parte inferiore del tubo principale e la batteria verrà via, così potrai caricarla fuori dalla bici, sostituirla o semplicemente pulire o effettuare la manutenzione della bici.



23. FAQs

CI SONO DUE DIMENSIONI DI BATTERIA, 800WH E 600WH. POSSO INSTALLARE UNA QUALSIASI DELLE DUE SULLA SCREE?

Sì. Tutti i modelli Scree permettono di utilizzare sia le batterie Powertube da 800 Wh sia quelle da 600 Wh. Se la tua bici è dotata di una delle due, puoi acquistare una batteria di riserva e installarla sulla bici in base alle tue preferenze. Assicurati di procurarti anche gli adattatori necessari (per poter montare la 600 Wh più piccola se la bici è fornita di serie con la 800 Wh, e viceversa, poiché le altezze delle batterie sono diverse, così come gli adattatori) per installarla correttamente all'interno. Inoltre, ti consigliamo di acquistare una copertura batteria aggiuntiva dal tuo rivenditore Mondraker (in questo modo avresti due batterie intercambiabili pronte all'uso) oppure, tecnicamente, smontare quella originale fissata sulla batteria e installarla sulla nuova, ma il materiale interno in schiuma tra le opzioni da 600 Wh e 800 Wh non è identico. Le batterie più vecchie e più pesanti da 750 Wh e 625 Wh potrebbero funzionare sui nuovi modelli Scree, ma Mondraker non fornisce gli adattatori necessari per montarle su questi telai. La bici funzionerebbe anche con il range extender Powermore senza batteria interna, ma Bosch non lo consiglia o la bici è pensata per essere utilizzata solo con il range extender, come suggerisce il nome.

QUANTO TEMPO IMPIEGANO A CARICARSI LE BATTERIE?

La batteria Powermore da 800 Wh impiega circa 6 ore per una ricarica completa, mentre quella da 600 Wh circa 4,5 ore se completamente scarica.

Se hai un PowerMore range extender, questo deve essere caricato separatamente e impiega circa 2,5 ore per una ricarica completa.

CI SONO INDICAZIONI O ACCORGIMENTI PARTICOLARI PER LA BATTERIA?

Nessuno in particolare. Puoi controllare la carica residua della batteria sul display Kiox 400c sul tubo superiore. Quando rimane circa il 30% di carica, l'assistenza del motore sarà leggermente ridotta, e sarà più evidente quando rimane solo il 10% di batteria. Non ci sono indicazioni o accorgimenti particolari da seguire.

I DERAGLIATORI POSTERIORI SRAM DI ULTIMA GENERAZIONE T-TYPE POSSONO FUNZIONARE DIRETTAMENTE COLLEGATI ALLA BATTERIA PRINCIPALE DELLA BICI. È POSSIBILE FARE LO STESSO SUI MODELLI SCREE?

Sì, tecnicamente è possibile. Bisogna acquistare gli accessori appropriati e instradare il cavo di alimentazione internamente alla batteria principale per poterlo fare.

LA MIA SCREE MONTA UNA TRASMISSIONE SRAM T-TYPE. SAREBBE POSSIBILE UTILIZZARE UNA TRASMISSIONE E UN DERAGLIATORE POSTERIORE SHIMANO?

Sì, assolutamente. Assicurati solo di procurarti un attacco deragliatore UDH aggiuntivo per il deragliatore posteriore Shimano.

QUAL È L'ASSISTENZA MASSIMA CHE POSSO OTTENERE DAL MOTORE BOSCH PERFORMANCE CX DELLA SCREE?

Il motore Performance CX di serie (BDU384Y) di Bosch offre 85 Nm e 600 W di potenza di picco. Tramite l'app Bosch Flow è possibile aumentare le prestazioni del motore fino a 100 Nm e 750 W di potenza di picco.

È POSSIBILE PERSONALIZZARE LE MODALITÀ DI ASSISTENZA SULLA SCREE?

Puoi personalizzare le modalità di assistenza del motore Bosch Performance CX di Scree nello stesso modo delle altre motorizzazioni della gamma Bosch tramite l'app Flow. Accedi all'app Flow, accendi la bici e connettiti al tuo Scree per personalizzare l'uscita del motore: supporto, assistenza iniziale alla pedalata tramite Dynamic, velocità massima in km/h o mph con l'assistenza fino a 25 km/h / 20 mph e coppia massima di 100 Nm, il tutto in ciascuna delle 4 modalità di supporto ECO, TOUR+, EMTB+ e TURBO. Puoi anche modificare le modalità di assistenza a tuo piacimento, utilizzando tutte e 4 o solo alcune se preferisci.



23. FAQs

QUANTO SI PUÒ PEDALARE CON LA NUOVA SCREE?

Questa è sempre una domanda difficile e dipende anche dal livello di assistenza che si utilizza, dalla forma fisica del ciclista, dal peso del ciclista e dalle condizioni di guida. Con la nuova batteria PT800Wh, un ciclista medio con un peso di 80 kg può affrontare circa 2.000 m di dislivello (6.500 ft) (1.500 m / 5.000 ft con la batteria PT600Wh) combinando diverse modalità di supporto e pedalare per fino a 4 ore in modalità ECO-TOUR+. Ancora, tutto dipende dalle condizioni di guida e dal livello fisico del ciclista. Il range extender PowerMore da 250 Wh aumenterebbe il tempo/distanza di percorrenza di +30% (con batteria PT800Wh) / +40% (con batteria PT600Wh) aggiungendo solo 1,5 kg di peso extra.

PEDALANDO CON IL POWERMORE RANGE EXTENDER, QUALE BATTERIA SI SCARICA PER PRIMA, QUELLA INTERNA O L'EXTENDER?

Per mantenere la corretta erogazione di potenza dal motore, entrambe le batterie si scaricano contemporaneamente. Questo è fondamentale per garantire la durata ottimale della batteria e un'assistenza costante del motore. Se installi un PowerMore quando la batteria interna sta per esaurirsi, il PowerMore verrà utilizzato come principale fonte di alimentazione fino a quando le cariche di entrambe le batterie (interna ed extender) non saranno uguali; successivamente, entrambe si scaricheranno equamente fino a esaurimento completo.

QUALI INFORMAZIONI MOSTRA IL DISPLAY DELLA SCREE?

Puoi trovare tutte le informazioni sui manuali del display e del telecomando seguendo questo link di BOSCH: <https://www.bosch-ebike.com/en/products/kiox-400c>

MI PIACEREBBE SAPERE PIÙ DETTAGLI SUL MOTORE BOSCH BDU384Y PERFORMANCE CX, DOVE POSSO TROVARE MAGGIORI INFORMAZIONI?

Segui questo link di BOSCH:

<https://www.bosch-ebike.com/en/products/performance-line-cx> e <https://www.boschebike.com/en/products/performance-line-cx-r>

QUALI TIPI DI MANUTENZIONE O CONTROLLI DI SICUREZZA RICHIEDE IL MOTORE BOSCH PERFORMANCE CX?

Assolutamente nessuna. Non è nemmeno necessario lubrificare alcuna parte dell'unità motrice né smontarla... tutto ciò che devi fare è prendertene cura come di una normale mountain bike. È comunque importante sottolineare, come precauzione valida per qualsiasi mountain bike, che le parti elettroniche e, in particolare, l'area del movimento centrale dell'unità motrice non devono mai essere pulite con una idropulitrice ad alta pressione. Non è consigliato usare getti d'acqua ad alta pressione per pulire direttamente l'asse delle pedivelle, poiché le parti elettroniche dell'unità motrice potrebbero essere seriamente danneggiate.

DI QUALE TAGLIA DI BICI HO BISOGNO?

La nuova Scree 2026 presenta un nuovo concetto a 5 taglie, con una nuova taglia ML a metà tra le taglie Medium e Large. Rispetto alla classica opzione a 4 taglie presente in altri modelli, questo nuovo approccio soddisfa perfettamente le esigenze di qualsiasi ciclista. Consulta i grafici della geometria per ulteriori informazioni e tutti i dettagli. Ecco una panoramica delle taglie consigliate in base all'altezza del ciclista.

<165 cm	165-170 cm	170-175 cm	175-180 cm	180-185 cm	185-190 cm	190-195 cm	>195 cm
S		M/L				XL	
	M			L			



Tutte le informazioni e le immagini contenute in questo documento sono fornite esclusivamente a titolo informativo e non costituiscono un contratto legale tra MONDRAKER e qualsiasi persona o entità. Le specifiche, le geometrie o qualsiasi altra informazione tecnica qui pubblicata sono soggette a modifiche senza preavviso.

© ® Tutti i marchi e modelli sono di proprietà di Blue Factory team, S.L.U. e sono protetti dalle leggi vigenti e dagli accordi internazionali applicabili.

MANUALES Y DOCUMENTOS



INSTRUCCIONES GENERALES Y DE SEGURIDAD

En esta guía técnica pueden aparecer los 3 iconos siguientes. Cada uno de ellos indica que deben tomarse las siguientes precauciones:

ADVERTENCIA:

No seguir las indicaciones o usar la bicicleta de forma inadecuada puede ocasionar graves lesiones o incluso la muerte. Estas tareas entrañan dificultad técnica y, si no se realizan de forma adecuada, podrían causar daños a tu bicicleta o dar lugar a la anulación de la garantía.

CUIDADO:

No seguir las indicaciones o usar la bicicleta de forma inadecuada puede ocasionar lesiones leves. Estas tareas entrañan dificultad técnica y, si no se realizan de forma adecuada, podrían causar daños a tu bicicleta o dar lugar a la anulación de la garantía.

INFORMACIÓN

Información imprescindible para realizar esta tarea correctamente y, así, evitar que se cause cualquier daño a la bicicleta o se pierda la garantía, pero que no supone ningún riesgo para las personas.

OTRAS CONSIDERACIONES

- El uso de piezas de repuesto no originales puede ocasionar daños, fallos de funcionamiento y accidentes que pueden tener graves consecuencias.
- Para realizar algunos de los pasos descritos en este manual se requieren habilidades superiores a las del usuario medio de bicicleta. En caso de no poder seguir alguno de estos pasos, lleva tu bicicleta a un servicio técnico autorizado Mondraker para el mantenimiento y sustitución de sus componentes. La instalación incorrecta de piezas de repuesto puede ocasionar fallos de funcionamiento, accidentes, lesiones y la anulación de la garantía.

LIMPIEZA Y CUIDADO

- Una vez desmontadas las piezas, se recomienda limpiar, engrasar y poner fijador de roscas (en caso necesario) en los componentes que se vayan a reutilizar.

LEYENDA DE SÍMBOLOS



Fijador de roscas grado medio. Loctite 243 o similar.



Grasa sintética de calidad para montaje.



Grasa especial de fricción para carbono.

1. GEOMETRÍA

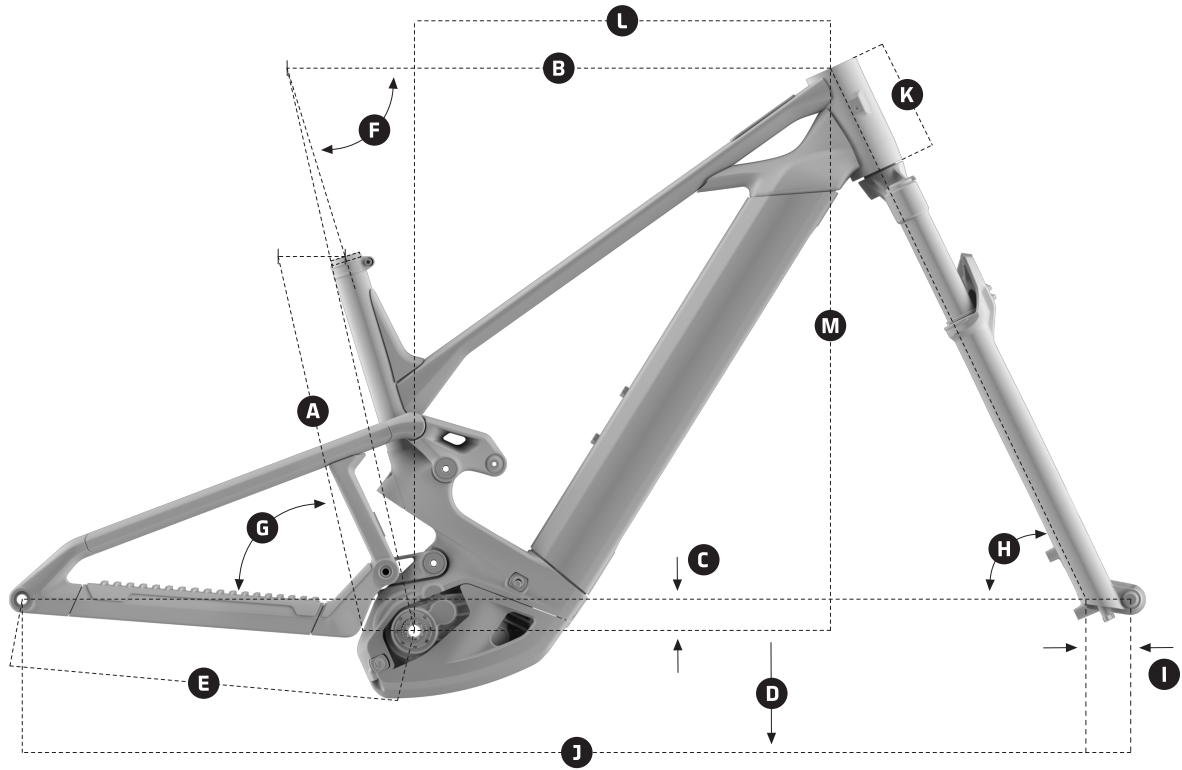

SCREE

TALLA DE CUADRO	S	M	ML	L	XL
A Longitud tubo sillín	380 mm	410 mm	435 mm	460 mm	490 mm
B Longitud tubo superior	587,6 mm	607,6 mm	628,8 mm	650,7 mm	672,8 mm
C Caída eje pedalier	-35 mm	-35 mm	-35 mm	-35 mm	-35 mm
D Altura eje pedalier	340 mm	340 mm	340 mm	340 mm	340 mm
E Longitud vainas	456 mm	456 mm	456 mm	456 mm	456 mm
F Ángulo tubo sillín real	74°	74°	74°	74°	74°
G Ángulo tubo sillín efectivo	77°	77°	77°	77°	77°
H Ángulo dirección	65,5°	65,5°	65,5°	65,5°	65,5°
I Offset de la horquilla	44 mm	44 mm	44 mm	44 mm	44 mm
J Distancia entre ejes	1221,2 mm	1241,2 mm	1263,3 mm	1287,4 mm	1311,5 mm
K Longitud pipa	125 mm	125 mm	130 mm	140 mm	150 mm
L Reach	440 mm	460 mm	480 mm	500 mm	520 mm
M Stack	644,6 mm	644,6 mm	649,2 mm	658,3 mm	667,4 mm



2. ESPECIFICACIONES TÉCNICAS DEL CUADRO

TALLAS DE CUADRO	S / M / ML / L / XL
TAMAÑO RUEDA DELANTERA	29"
BUJE DELANTERO	110mm x 15mm (BOOST)
TAMAÑO RUEDA TRASERA	29"
BUJE TRASERO	148mm x 12mm (BOOST)
EJE TRASERO	12X148 P1.0 L180
CAPACIDAD TOTAL DE BIDONES / RANGE EXTENDER	2 POSICIONES, 1 PORTABIDONES / RANGE EXTENDER
MOTOR	BOSCH PERFORMANCE LINE CX
EJE PEDALIER	BOSCH
BATERÍA	800Wh / 600Wh
COMPATIBILIDAD CON RANGE EXTENDER	BOSCH POWERMORE 250Wh
RECORRIDO TRASERO	130mm
AMORTIGUADOR TRASERO	165 x 45mm TRUNNION, 30 x 8mm
RECORRIDO DE HORQUILLA	150mm
DIÁMETRO DE TIJA	31.6mm / 34.9mm
LÍNEA DE CADENA	55mm
DIRECCIÓN	ZS56 / ZS56, 1-1/8", 1.5"
TAMAÑO MÁXIMO DE PLATO	34T
FRENO TRASERO	POST MOUNT, DIRECT 220mm max
TAMAÑO MÁXIMO DE RUEDA	29" x 2.6" (66-622)

3. LONGITUD DE INSERCIÓN DE TIJA

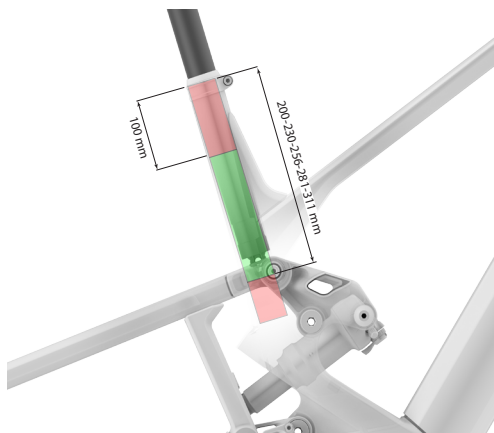

TALLA CUADRO	MIN. (mm)	MAX. (mm)
XL	100	311
L	100	281
ML	100	256
M	100	230
S	100	200



4. COMPONENTES TRANSMISIÓN

4.1. GUIACADENA

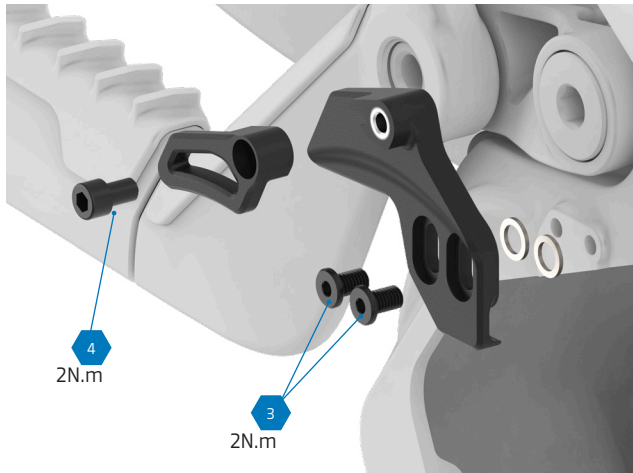

4.2. PLATO



Consultar el manual del fabricante del plato o araña para saber si es compatible con la junta tórica.

5. TAPA DEL MOTOR

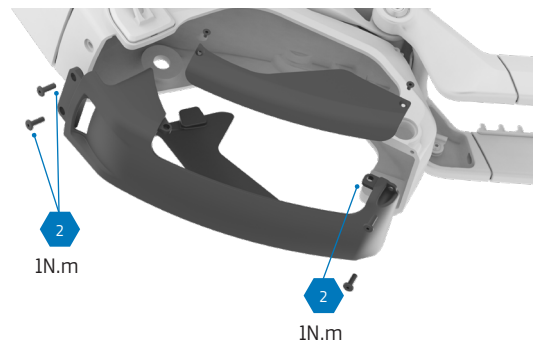
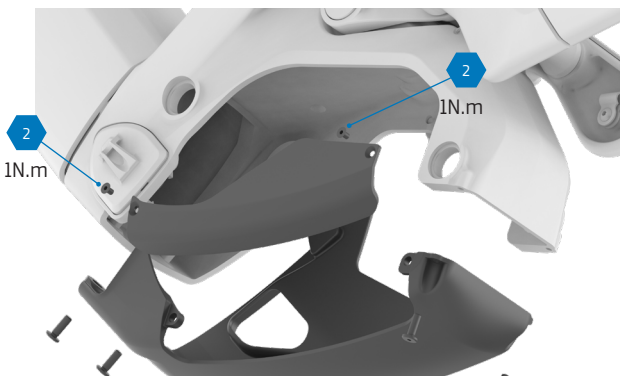



6. RETIRAR MOTOR



No usar Loctite 243

6.1. CONEXIONES DEL MOTOR

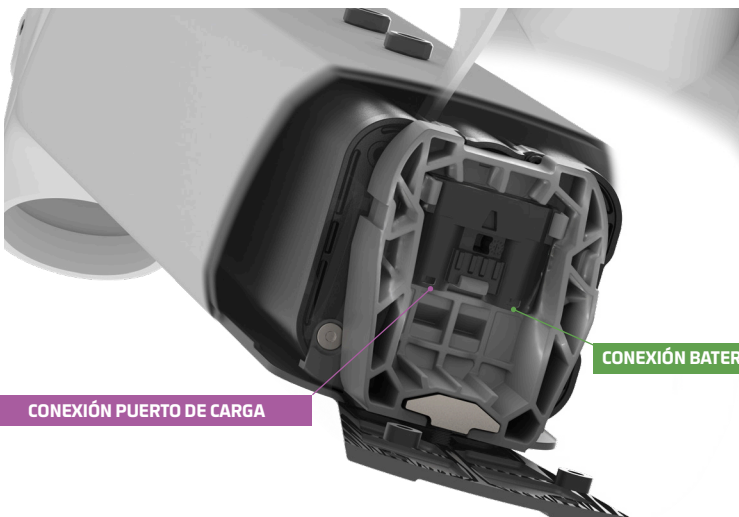

CONEXIÓN PUERTO DE CARGA

CONEXIÓN BATERÍA



7. PUERTO DE CARGA

7.1. RETIRAR PUERTO DE CARGA

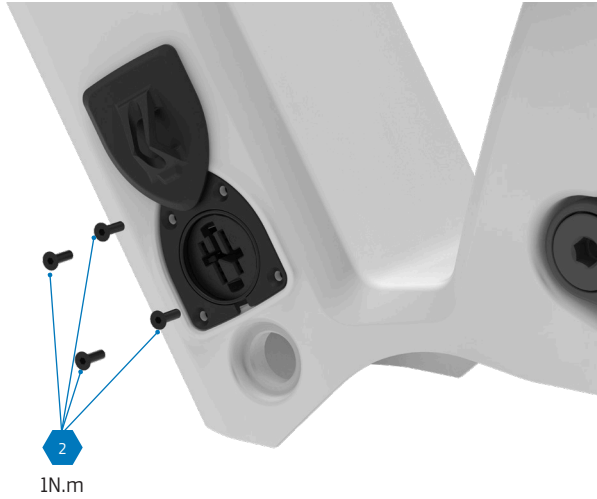

2
1N.m

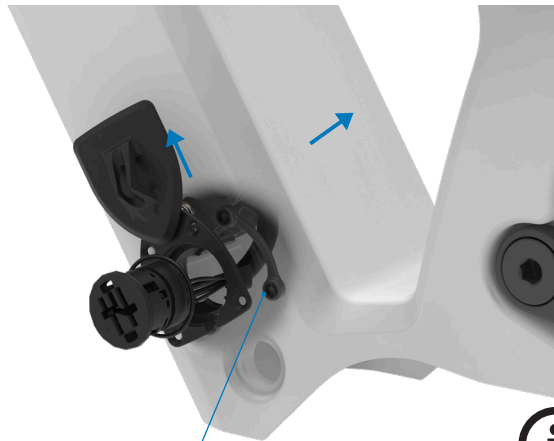

Soltar tapa lateralmente



Las 2 bases metálicas
salen por el interior
del tubo diagonal



8. SACAR BATERÍA

PASO 1

Suelta el tornillo el primer tramo de rosca. La batería se descolgará sin llegar a caer.

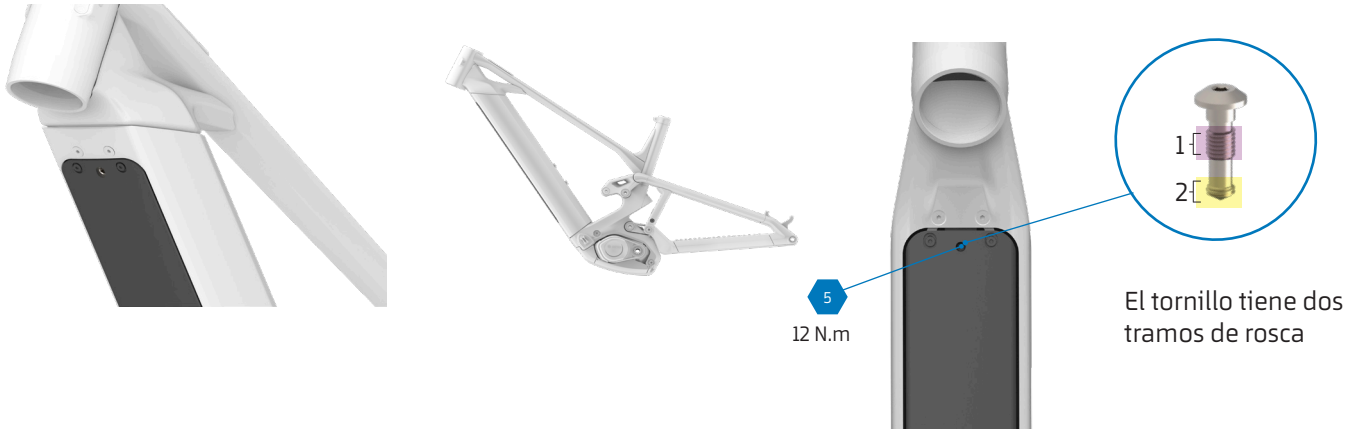

FIN DEL PASO 1

Ahora sujeta la batería con la mano y continúa desatornillando el segundo tramo del tornillo.



PASO 2

La batería caerá. Ten cuidado que la batería es pesada. Si no la sujetas firmemente, la batería puede caer al suelo y romperse.





9. GUIADO INTERNO DE CABLES

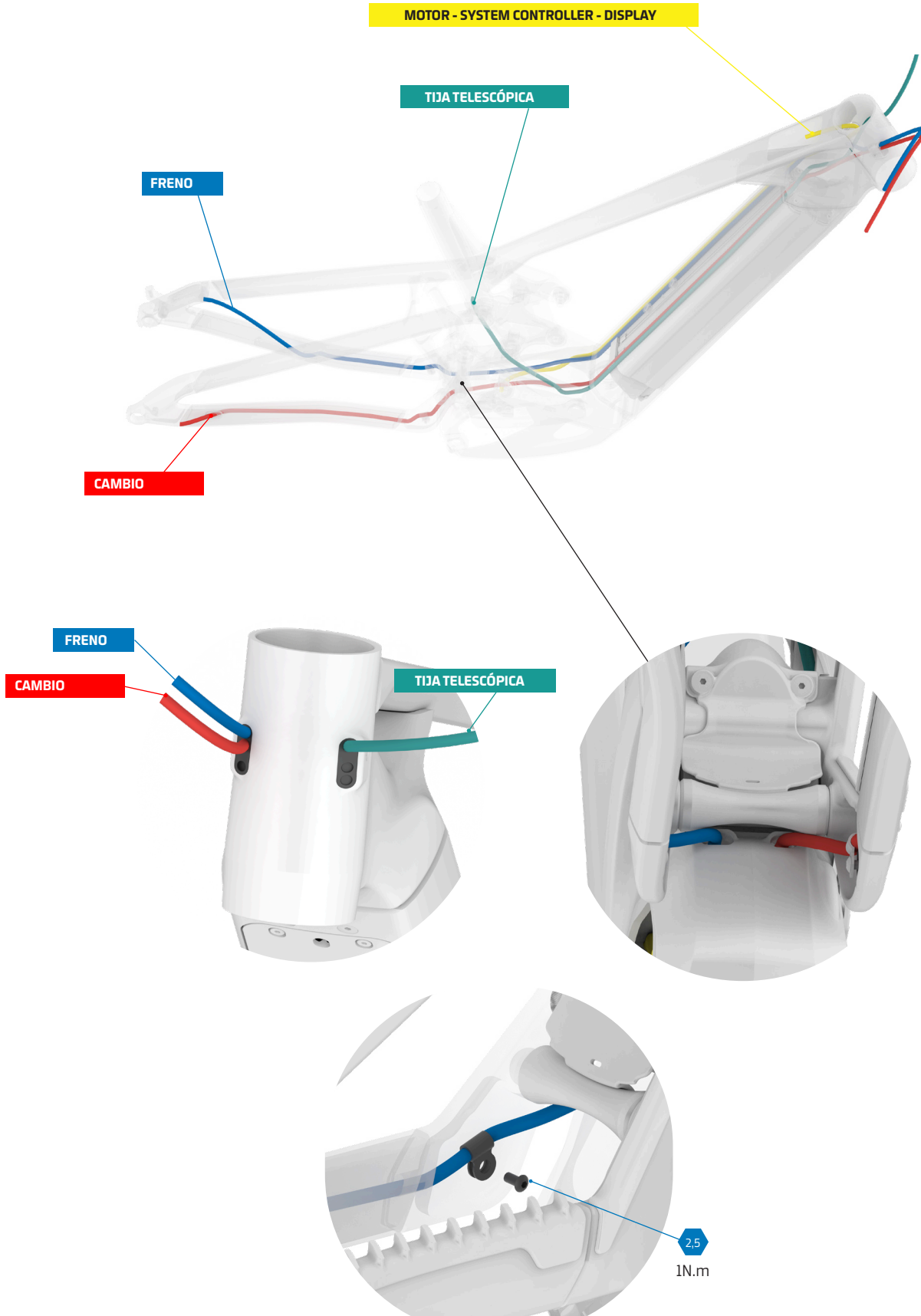



10. ANCLAJE DE LA BATERÍA

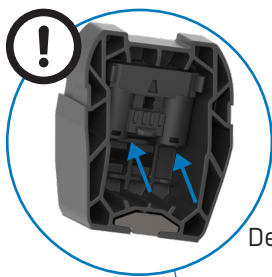
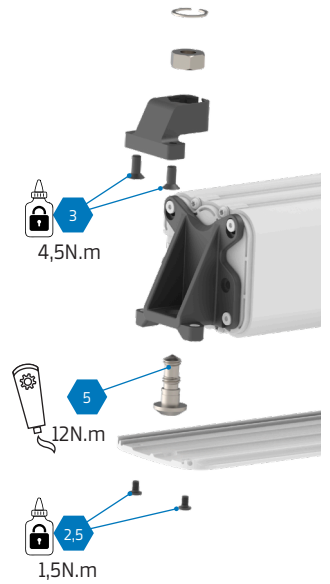
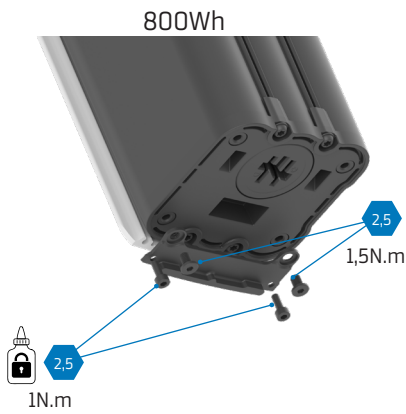
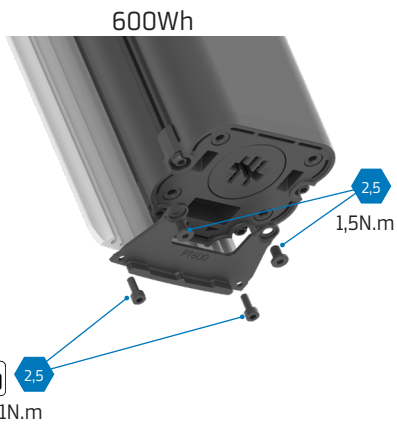
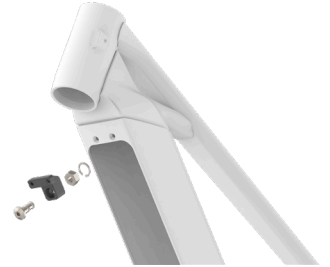
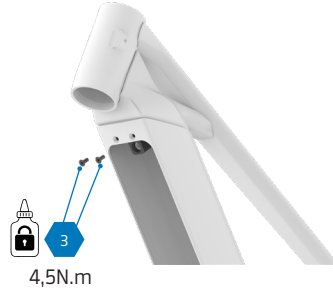
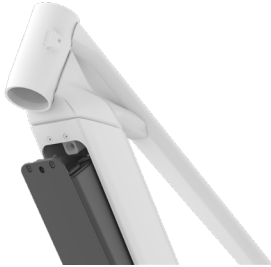

Desconectar los cables





11. CONVERSIÓN DE BATERÍA 600 WH / 800 WH

11.1 INSTALAR SUJECIONES

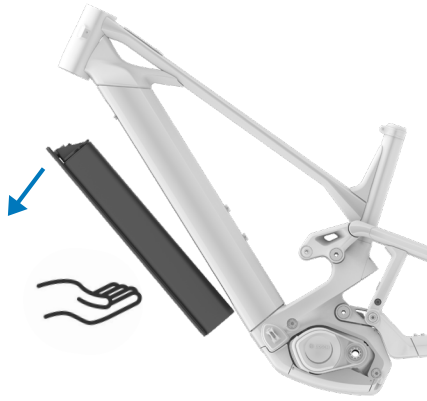

600Wh



800Wh

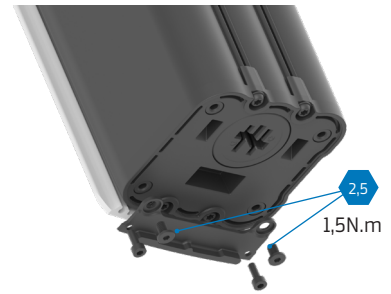

600Wh

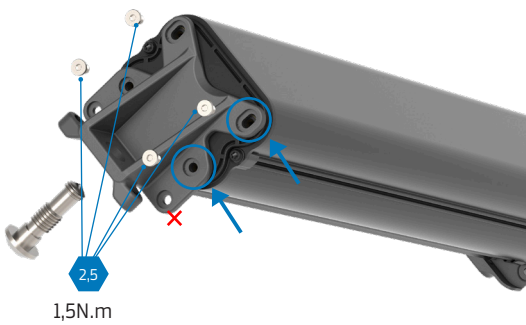

800Wh

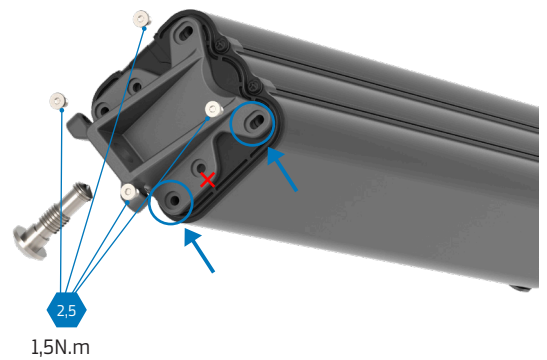



11. CONVERSIÓN DE BATERÍA 600 WH / 800 WH

11.2. INSTALAR TAPA DE BATERÍA

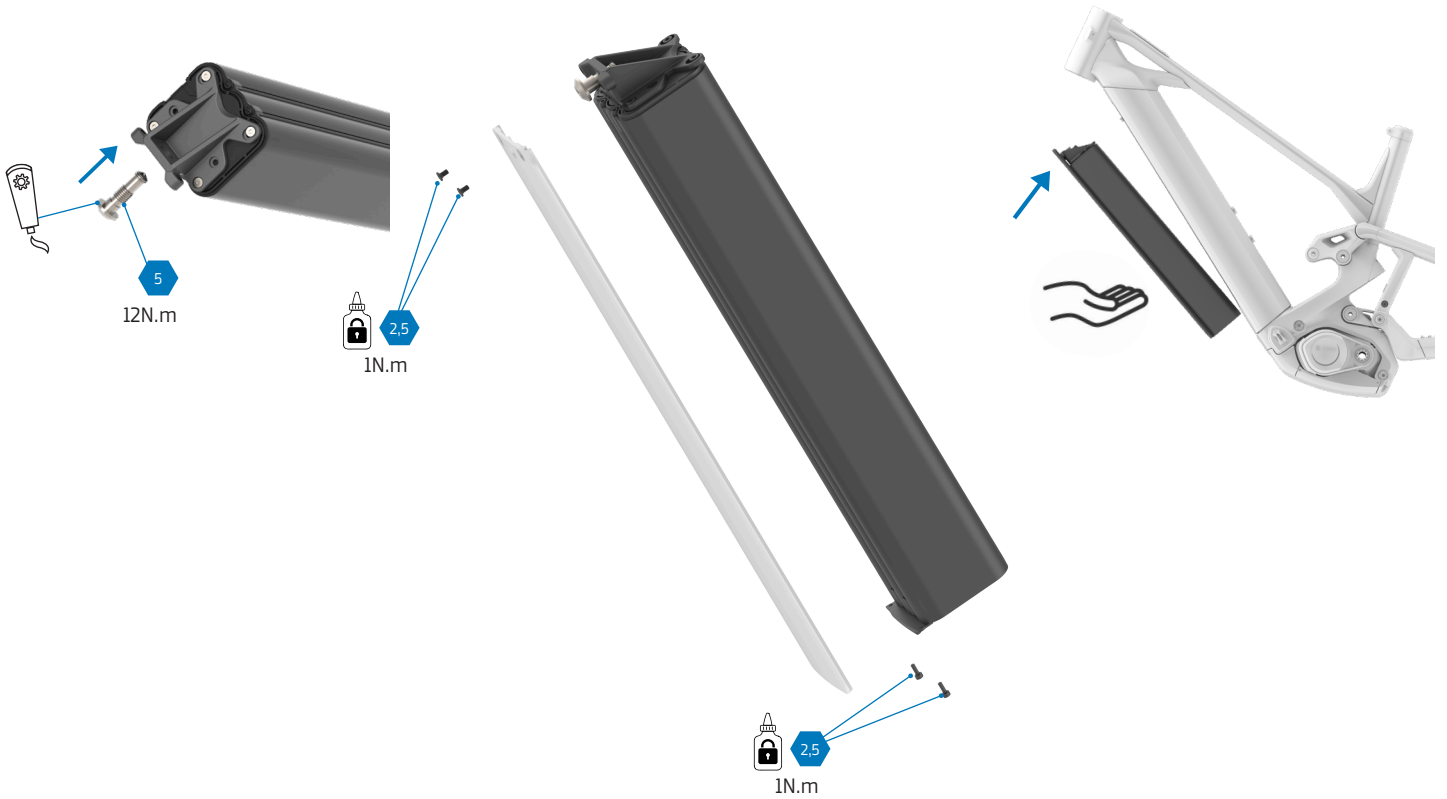

8. 4. NÚMEROS DE REFERENCIA



SOPORTE FRONTAL
BATERÍA 800Wh/600Wh
Ref. 099.25049



SOPORTE POSTERIOR
DE BATERÍA 800Wh
Ref. 099.26020



SOPORTE POSTERIOR
DE BATERÍA 600Wh
Ref. 099.26021



8. 5. PIEZAS DE REPUESTO NECESARIAS PARA UNA SEGUNDA BATERÍA

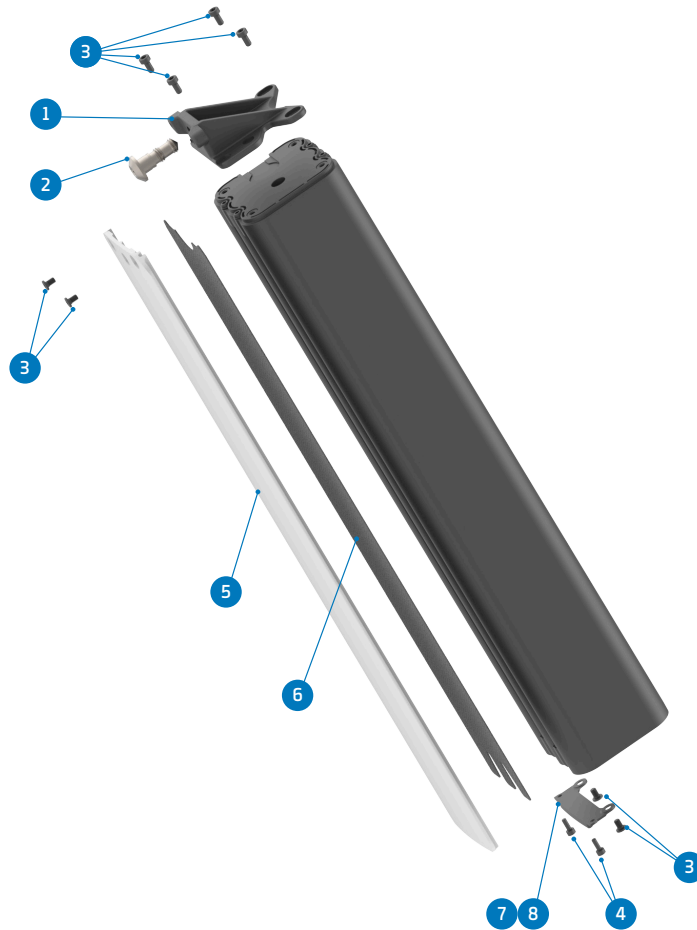

ITEM	DESCRIPTION	QTY.	PART NUMBER
1	BATTERY MOUNT BRACKET FRONT	1	099.25049
2	BATTERY RELEASE SCREW	1	099.25051
3	SCREW BOLT M4X6	8	099.25052
4	SCREW BOLT M4X8	2	099.12116
5	BATTERY COVER	1	Refer to B2B web for color options
6	FOAM FOR BATTERY COVER	1	099.25089
Choose between:			
7	BATTERY HOLDER REAR 800Wh (only for 800Wh battery)	1	099.26020
8	BATTERY HOLDER REAR 600Wh (only for 600Wh battery)	1	099.26021
9	FOAM FOR 600Wh BATTERY (only 600wh battery)	1	099.25097



SOPORTE POSTERIOR
DE BATERÍA 800Wh
Ref. 099.26020

SOPORTE POSTERIOR
DE BATERÍA 600Wh
Ref. 099.26021



9. PROTECTOR DE ESPUMA PARA LA BATERÍA

9.1. ESPUMA PARA EL CUADRO

Ref. 099.25088



10. BOSCH SYSTEM CONTROLLER KIOX 400

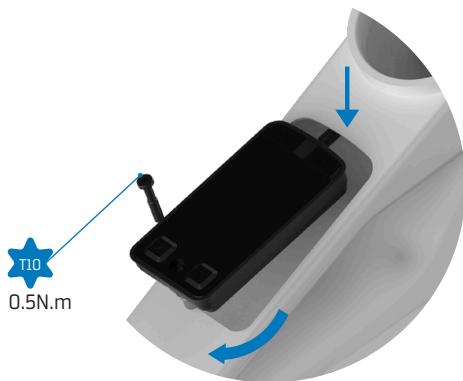

11. BOSCH MINI REMOTE



12. CHAINSTAY PROTECTOR



Los protectores de vainas, vienen sin agujero para desviadores mecánicos o con cable. En la parte posterior hay una marca para perforar la salida del cable.

Para un resultado óptimo, se recomienda utilizar alicates de perforación.



13. RANGE EXTENDER BOSCH POWERMORE KIT

EU28, CH, NO, AUS, NZ

POWERMORE 250 KIT (BBP3620 EU28,CH,NO,AUS,NZ)
incl. battery holder, bottle holder, screws, IBD packaging
EB12.100.05G

US, CANADA

POWERMORE 250 KIT (BBP3625 US, CAN) incl.
battery holder, bottle holder, screws, IBD packaging
EB12.100.05H



CABLE POWERMORE 150MM (BCH3923_150) **EB12.120.036**



14. GUARDABARROS

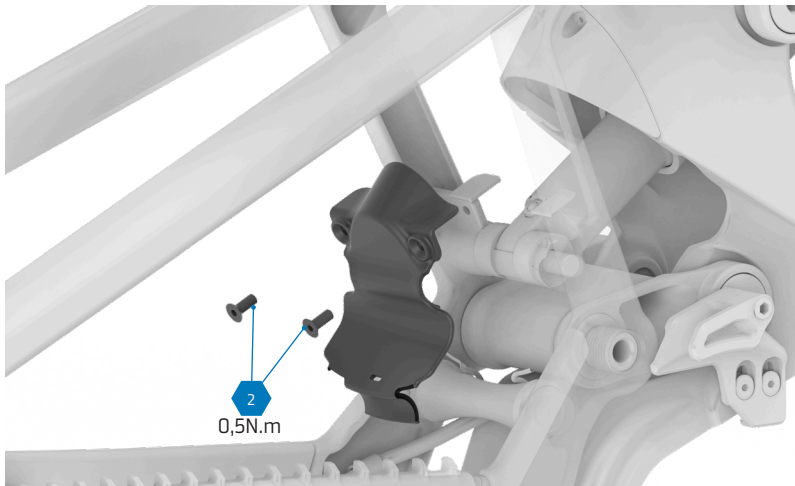
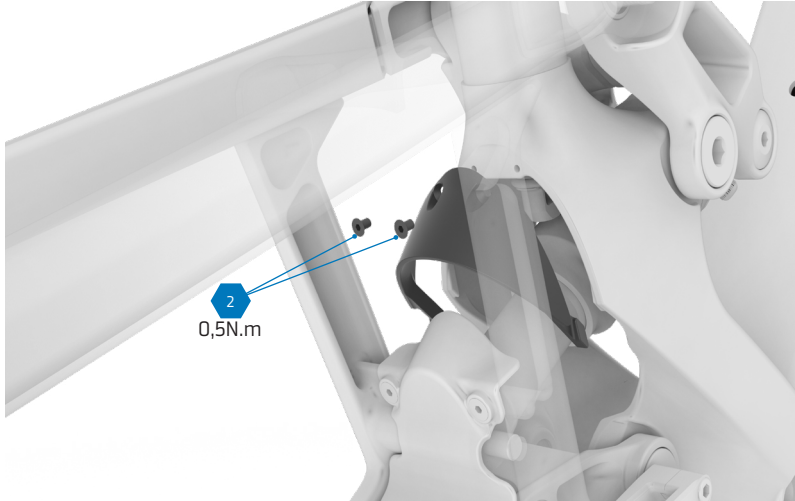

15. CIERRE DE SILLÍN

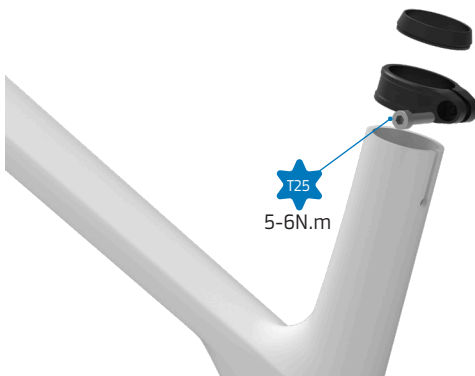

Se recomienda usar sobre la tija grasa de fricción para carbono

16. GUÍA DE INSTALACIÓN DE LA BIELETA SUPERIOR

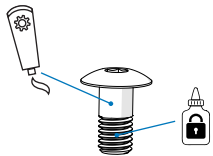
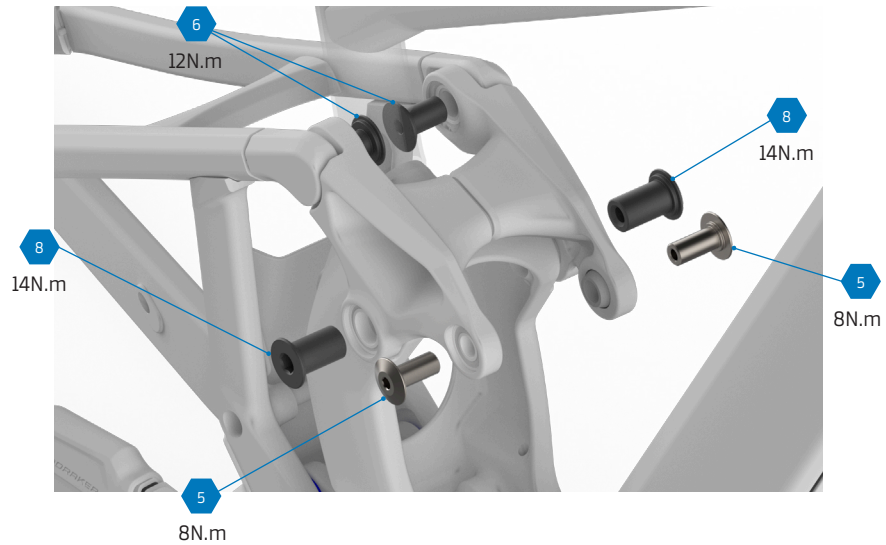

Para los tornillos principales aplica grasa al eje y Loctite 243 o similar a las roscas.

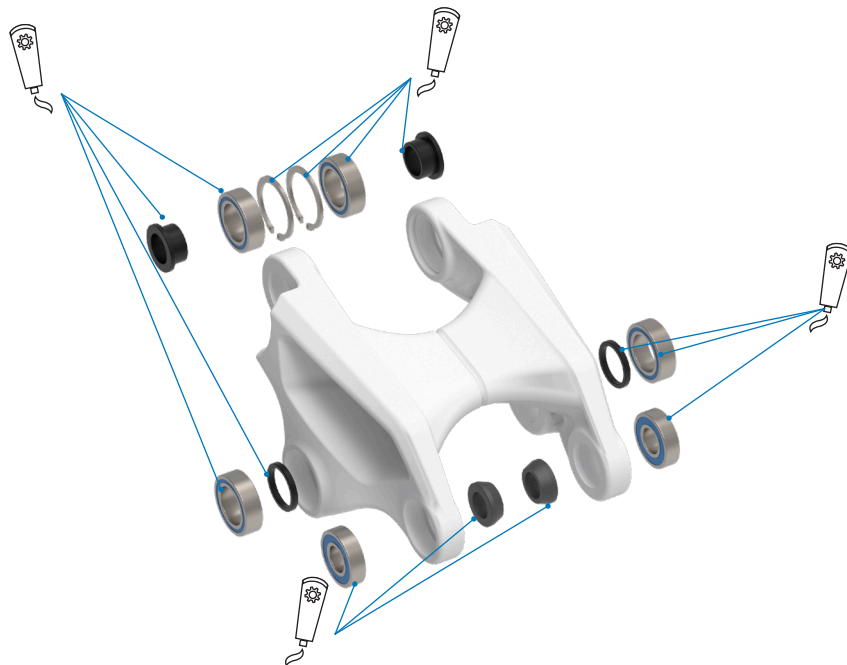

Aplica grasa.



17. GUÍA DE INSTALACIÓN DE LA BIELETA INFERIOR

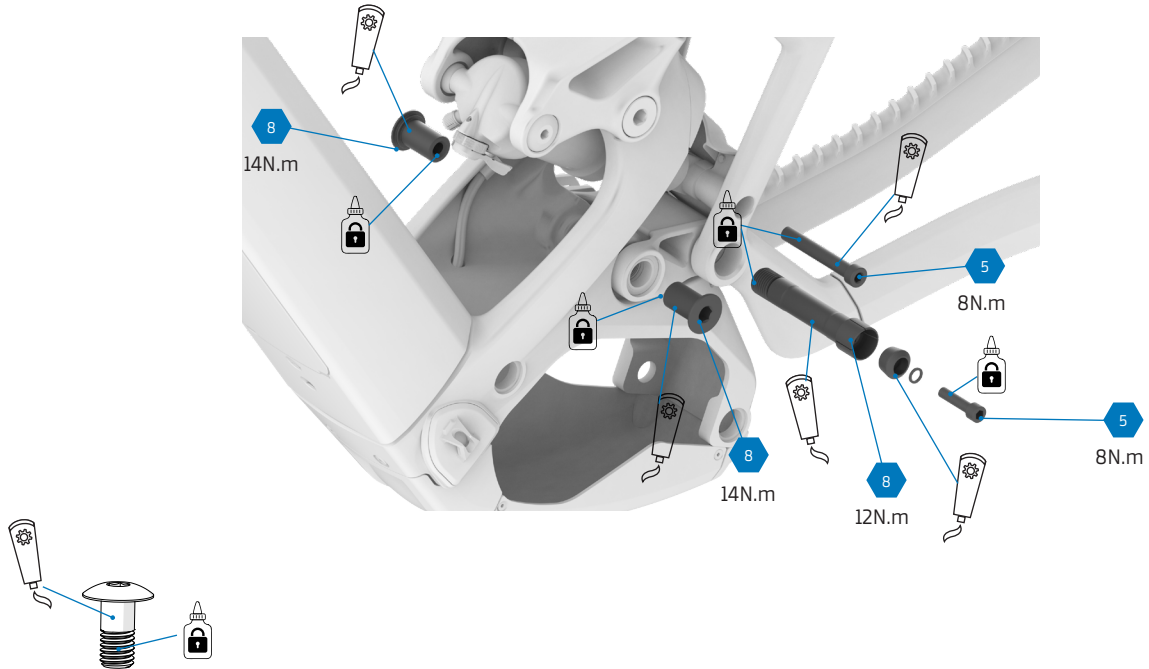

Para los tornillos principales aplica grasa al eje y Loctite 243 o similar a las roscas.



Aplica grasa.

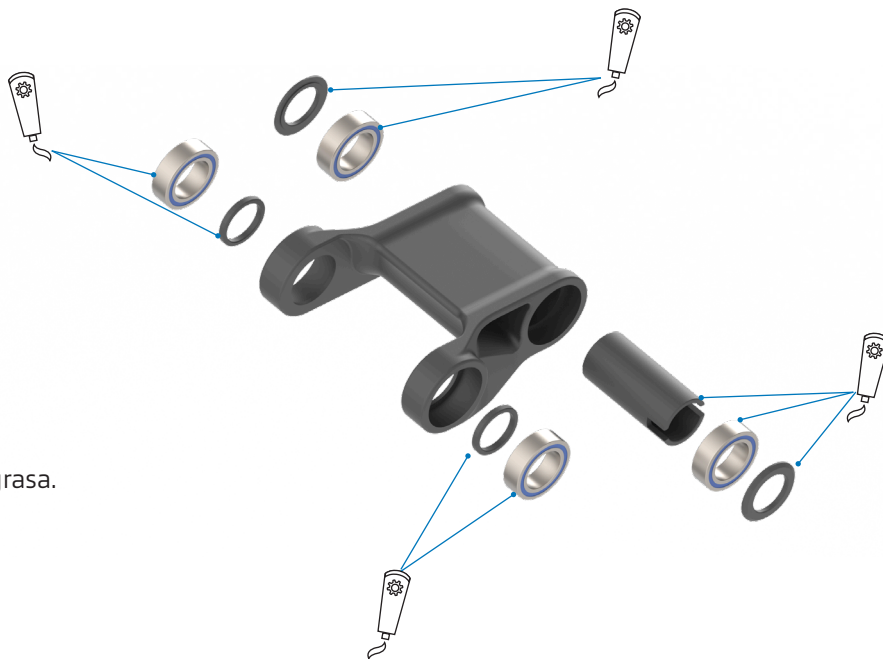



19. CONEXIÓN CON SMARTPHONE



eBike Flow app



Enciende la bici.
Una vez encendida, pulsa durante 5 segundos el botón de Power hasta que un LED azul comienza a parpadear.
En ese momento abre la aplicación eBike Flow y sigue las instrucciones en tu teléfono para realizar el emparejamiento.



20. MONTAJE DE LA POTENCIA

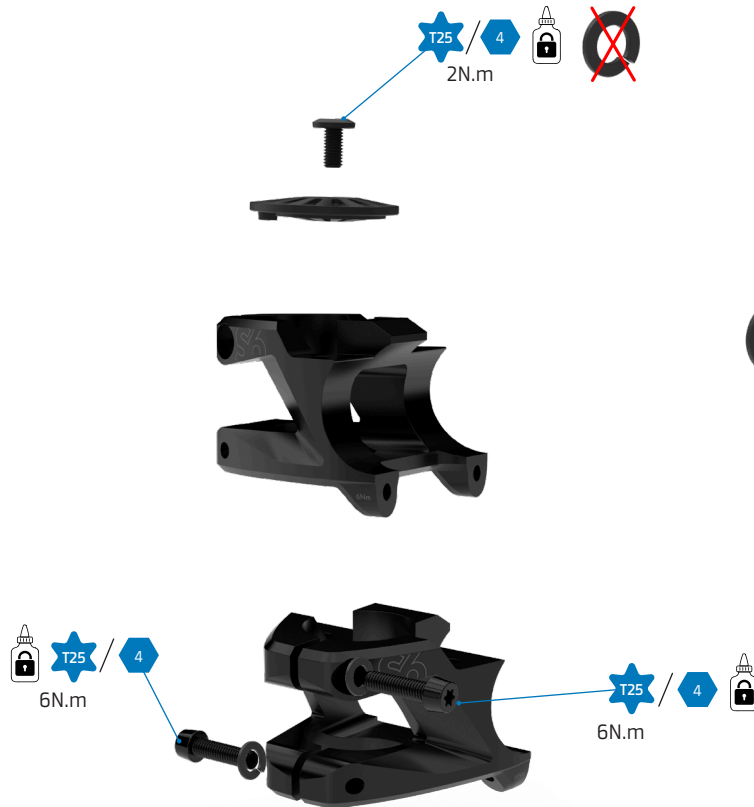

Los 6 tornillos de la potencia, a excepción del tornillo de la tapa de la dirección, deben llevar una arandela tipo Grover.

1. Inserción de la potencia

Desliza el cuerpo de la potencia sobre el tubo de dirección de la horquilla hasta que asiente correctamente.

2. Ajuste de la dirección (Precarga)

Coloca la tapa superior de dirección (top cap) y su tornillo correspondiente. Aprieta el tornillo superior a un par máximo de 1 Nm para realizar la precarga de los rodamientos y eliminar cualquier holgura en la dirección.

3. Apriete de los tornillos laterales

Alinea la potencia con la rueda delantera. Aprieta los tornillos laterales de fijación de forma gradual y alternada para distribuir la carga. Incrementa la tensión progresivamente (p. ej., el superior a 4 Nm, el inferior a 4 Nm, luego ambos a 5 Nm) hasta que los dos tornillos alcancen el par de apriete final exacto de 6 Nm.

Consejo de montaje:

Resulta más fácil alinear visualmente la potencia con la rueda delantera si el manillar ya está instalado. Para ello, realiza este paso aplicando solo una ligera tensión a los tornillos laterales, procede al Montaje del manillar (Sección 2), realiza la alineación final de todo el conjunto y, por último, aplica el par de apriete definitivo de 6 Nm a los tornillos laterales de la horquilla.

21. MONTAJE DEL MANILLAR

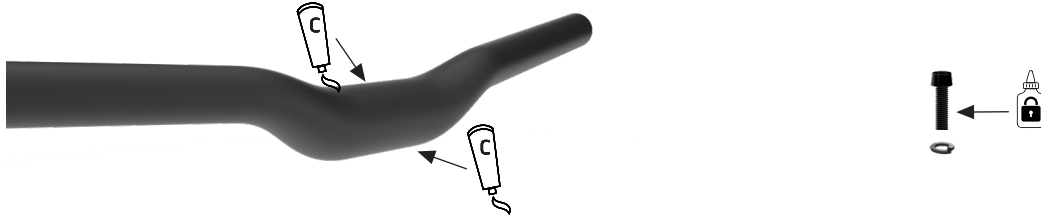

Aplica una capa fina de pasta de montaje específica para carbono en la zona de contacto entre el manillar y la potencia. Si las roscas de los tornillos están secas, aplica una pequeña gota de LOCTITE 243.

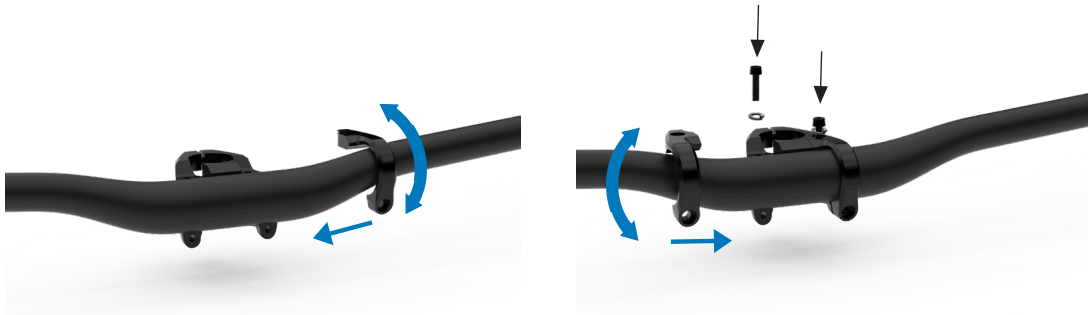

Introduce la placa frontal de la potencia desde la parte más estrecha del manillar y deslízala hacia el centro con cuidado para evitar arañar la superficie del componente. Ajústala e introduce el tornillo superior para sujetarla en su sitio. No lo aprietes al par final.



Coloca los dos tornillos superiores y enróscalos varias vueltas a mano sin aplicar el par de apriete final. A continuación, introduce los dos tornillos inferiores sin apretar.

Nota: Si resulta difícil alinear o enroscar los tornillos inferiores, afloja ligeramente los superiores para facilitar la entrada y vuelve a intentarlo.



21. MONTAJE DEL MANILLAR

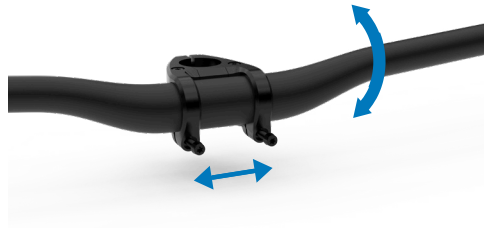

Ajusta la rotación y el centrado del manillar hasta alcanzar la posición deseada.

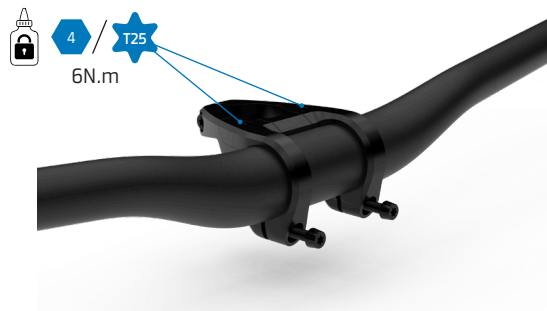

Aprieta los tornillos superiores de forma gradual y alternando los lados. Incrementa la tensión progresivamente (p. ej., 4 Nm, luego 5 Nm en cada lado) hasta alcanzar el par de apriete final exacto de 6 Nm. Es de vital importancia que ambos tornillos superiores queden completamente fijados a 6 Nm en este paso.

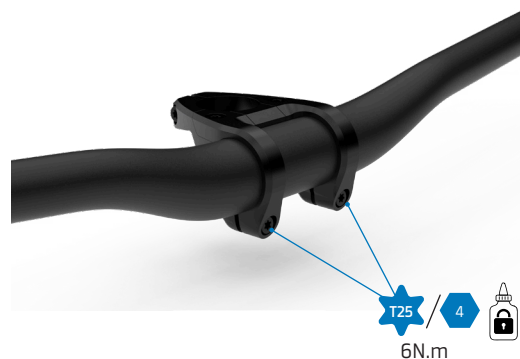

Con el manillar en su posición definitiva, aprieta los tornillos inferiores de forma gradual y alternando entre el lado izquierdo y el derecho (4 Nm, 5 Nm y finalmente 6 Nm) para distribuir la carga uniformemente.

Verifica visualmente el correcto acoplamiento de la potencia. Por diseño, no debe existir ningún hueco entre las piezas en la parte superior; la holgura de apriete debe quedar exclusivamente en la parte inferior. Finalmente, revisa con la llave dinamométrica que los cuatro tornillos se mantienen en el par especificado de 6 Nm. Y limpia el exceso de grasa que pueda haber.



22. SPARE PARTS
SCREE

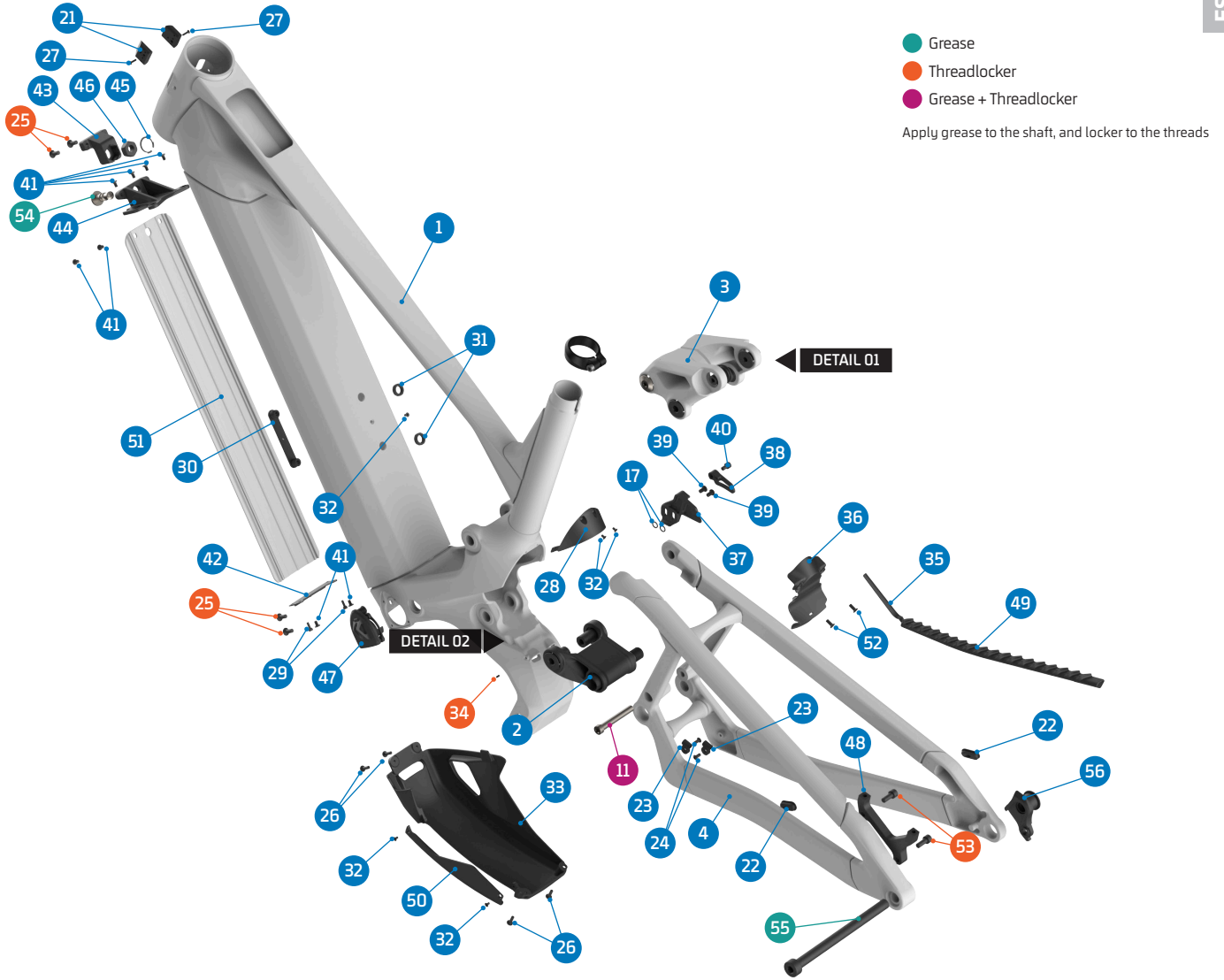

ITEM No.	DESCRIPTION	QTY.	PART NUMBER	TORQUE
1	FRONT TRIANGLE	1		
2	SCREE LOWER LINK	1	099.26009	
3	SCREE UPPER LINK	1	Refer to B2B web for color options	
4	SCREE REAR TRIANGLE	1		
5	BEARING, 24X15X7 (3802-2RS)	8	SET 1	
6	BEARING, 10x22x6 (6900V-2RS)	2	SET 1	
7	C-RING	2	SET 3	
8	MAIN AXLE	1	SET 4	12Nm
9	UPPER LINK-RT SPACER	2	SET 3	
10	PIVOT AXLE, M12	2	SET 3	12Nm
11	SHOCK BOLT	1	SET 2 / 099.24022	8Nm
12	SPACER	1	SET 4	
13	SPACER, 15x27x2	2	SET 4	
14	SPACER, 10x17x6	2	SET 2	
15	SPACER, 15x19x2.5t	4	SET 3 / 4	
16	TAPER NUT	1	SET 4	
17	SPACER	3	SET 4 / 5	
18	SCREW BOLT, M6x25	1	SET 4	8Nm
19	PIVOT AXLE, M15	4	SET 3 / 4	14Nm
20	SHOCK BOLT	2	SET 2	8Nm
21	CABLE GUIDE	2	SET 7	
22	CABLE RUBBER	2	989.13010	
23	SINGLE CABLE GUIDE	2	099.22064	
24	SCREW BOLT, M4x8	2		1Nm
25	SCREW BOLT, M5x12	4	099.12141	4,5Nm
26	SCREW BOLT, M4x12	4	099.20078	
27	SCREW BOLT, M3x10	2	SET 7	1Nm
28	SCREE FRONT TRIANGLE FENDER	1	099.26016	
29	SCREW BOLT, M3x8	2	099.12116	2Nm

ITEM No.	DESCRIPTION	QTY.	PART NUMBER	TORQUE
30	BOTTLE CAGE STAND	1	099.25072	
31	BOTTLE CAGE STAND SPACERS	2	099.25074	
32	SCREW BOLT, M3x5	5	099.25028	2Nm
33	MOTOR COVER	1	099.26017	
34	SCREW BOLT, M3x5	1		1Nm
35	CHAINSTAY PROTECTOR YOKE	1	099.26018	
36	REAR TRIANGLE FENDER	1	099.26019	
37	CHAIN GUIDE, BASE	1	SET 5	
38	CHAIN GUIDE, OUTER	1	SET 5	
39	SCREW BOLT, M5x12	2	SET 5	2Nm
40	SCREW BOLT, M5x8	1	SET 5	2Nm
41	SCREW BOLT, M4x6	8	099.25052	1,5Nm
42	COVER BRACKET 800WH	1	099.26020	
	COVER BRACKET 600WH	1	099.26021	
43	BATTERY MOUNT	1	099.25082	
44	BATTERY MOUNT BRACKET	1	099.25049	
45	C-RING	1	099.25083	
46	NUT	1	099.25084	
47	CHARGE PLUG SET	1	099.24064	
48	DISC MOUNT	1	SET 6	
49	CHAINSTAY PROTECTOR	1	099.26022	
50	SKID PLATE LEFT SIDE COVER	1	099.26023	
51	BATTERY COVER	1	Refer to B2B web for color options	
52	SCREW BOLT, M4x10	2		1 Nm
53	SCREW BOLT, M6x15	2	SET 6	12Nm
54	BATTERY RELEASE SCREW	1	099.25051	12Nm
55	REAR AXLE	1	112.90027	
56	HANGER	1	SRAM UDH	



DETAIL 01

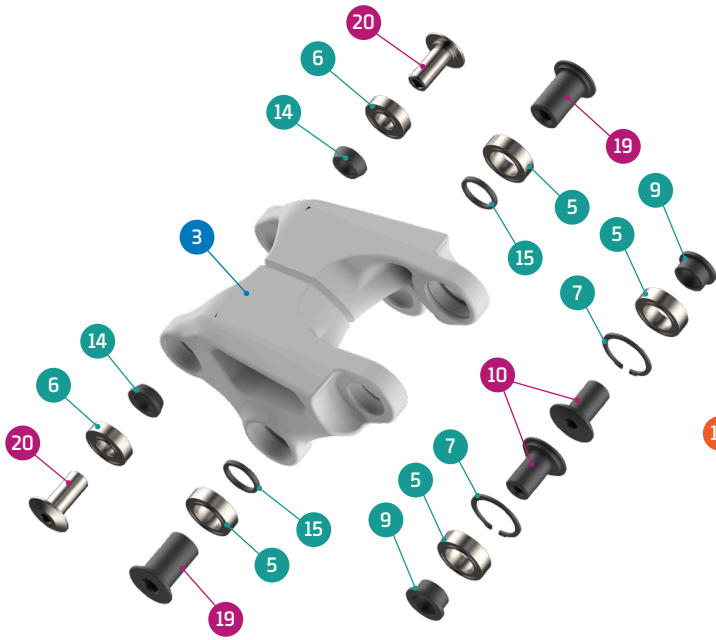

DETAIL 02

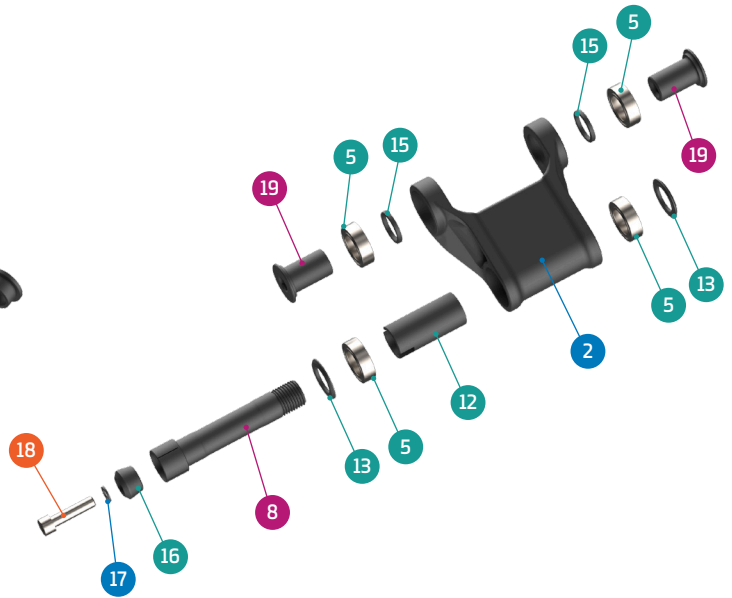

FOAM FOR BATTERY (600WH)

FOAM FOR MAIN TUBE

FOAM FOR BATTERY COVER

SET 7

SET 6

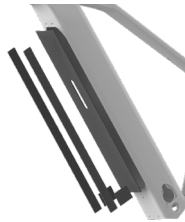

CABLE GUIDE KIT

DISC ADAPTOR KIT

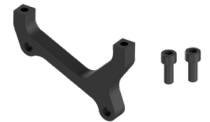

SET 1

SET 2

SET 3

SET 4

SET 5

ZERO BEARING KIT 26

SHOCK HARDWARE KIT 22

UPPER LINK KIT 30

LOWER LINK KIT 37

CHAIN GUIDE PLATE + BOLTS

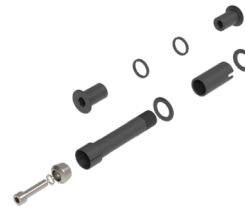

PART NUMBER	DESCRIPTION	COMPONENTS
099.22101	SET 1: ZERO BEARING KIT 26	BEARING 3802-2RS, 24x15x7 (x8) / BEARING 6900V-2RS, 10x22x6 (x2)
099.24200	SET 2: SHOCK HARDWARE KIT 22	SPACER (x2) / SHOCK BOLT (x2) / SHOCK BOLT (x1)
099.22300	SET 3: UPPER LINK KIT 30	SPACER, 15x19x2.5T (x2) / UPPER LINK-RT SPACER (x2) / PIVOT AXLE, M12 (x2) / PIVOT AXLE, M15 (x2) / C-RING (x6)
099.25400	SET 4: LOWER LINK KIT 37	SPACER, 15x27x2 (x2) / SPACER, 15x19x2.5t (x2) / INNER LOWER LINK SPACER (x1) / PIVOT AXLE, M10 (x1) / AXLE NUT, M10 (x1) / MAIN AXLE (x1) / SPACER (x1) / TAPER NUT (x1) / SCREW BOLT (x1)
099.24018	SET 5: CHAIN GUIDE PLATE + BOLTS	CHAIN GUIDE BASE (x1) / CHAIN GUIDE OUTER PLATE (x1) / SCREW BOLT, M5x12 (x2) / SCREW BOLT, M5x8 (x1) / WASHER 5x9x1t (x4)
099.25018	SET 6: DISC ADAPTOR KIT	DISC ADAPTOR (x1) / SCREW BOLT (x2)
099.25013	SET 7: CABLE GUIDE KIT	CABLE GUIDE (x1) / SCREW BOTL M2.5X5L (x1) / SCREW BOLT M3X10L (x1)
099.25088	FOAM KIT FOR MAIN TUBE	
099.25089	FOAM FOR BATTERY COVER	
099.25097	FOAM FOR 600Wh BATTERY	



23. FAQs

¿CUÁL ES LA DIFERENCIA ENTRE LA NUEVA SCREE Y LA CRAFTY CARBON?

Tanto la Scree como la Crafty Carbon son las eMTB más versátiles de Mondraker, pero cada una está diseñada para un uso diferente, con cuadros, cinemáticas, geometría y recorridos de suspensión distintos.

Scree es un modelo de Trail completamente nuevo, específico, con 130 mm de recorrido trasero y 150 mm delantero, construido en nuestro aluminio Stealth alloy, mientras que Crafty Carbon es un modelo de Enduro con 150 mm traseros y 160 mm delanteros, y cuadro en Stealth Air Carbon.

Ambas incorporan el motor Bosch Performance CX Gen 5 más reciente y baterías de 600Wh o 800Wh. Las dos familias están disponibles en 5 tallas con geometría específica para cada una. También montan la última generación del motor Bosch Performance CX con hasta 100 Nm y 750 W, compatibles con baterías de 800Wh y 600Wh para la mejor experiencia de conducción.

¿CUÁNTO PESA EL CUADRO DE LA NUEVA SCREE?

El cuadro de la Scree pintado, con su tornillería completa y demás accesorios, pero sin amortiguador trasero, en talla ML pesa aproximadamente 4,900 kg.

¿CUÁNTO MÁS LIGERA ES LA BATERÍA DE 600WH RESPECTO A LA DE 800WH?

La Powertube 800Wh pesa 3.990 gramos y la nueva Powertube 600Wh pesa 3.070 gramos. Ambas cuentan con celdas de batería 21700 de última generación.

¿QUÉ AMORTIGUADORES SON COMPATIBLES CON LA NUEVA SCREE?

Scree es compatible con cualquier amortiguador inline, pues su cinemática está optimizada específicamente para este tipo de amortiguadores. También puede montar amortiguadores con cartucho externo como la serie Float X o RockShox SuperDeluxe. Para modelos de mayor volumen es obligatorio verificar el espacio antes de montarlos, ya que podrían no encajar. La Scree utiliza amortiguadores con una medida métrica de 165x45mm, con anclaje superior Trunnion y anclaje inferior estándar de 30x8 mm.

¿QUÉ CARACTERÍSTICAS CINEMÁTICAS OFRECE LA NUEVA SCREE?

El sistema Zero de la scree ha sido actualizado siguiendo las últimas evoluciones aplicadas a otros modelos recientes de Mondraker, adaptado aquí a un uso de Trail más versátil.

La Scree presenta un 20,5% de progresividad, una relación de palanca mayor que la hace más sensible en el inicio, y curvas de anti-squat y anti-rise ligeramente más bajas para un mejor rendimiento general de la suspensión trasera.

¿CUÁL ES EL MÁXIMO RECORRIDO DE HORQUILLA COMPATIBLE CON LA SCREE?

Scree es compatible con horquillas de hasta 160 mm de recorrido o 580 mm del eje a la base de la pipa de dirección.

¿ES POSIBLE MONTAR UN DISCO DE FRENO TRASERO DE 220 MM EN LA SCREE?

Sí, Scree es compatible con discos traseros de 220 mm. Aunque no lo recomendamos, es posible montarlos, al igual que en los modelos Crafty Carbon.

¿CUÁL ES EL ANCHO MÁXIMO DE CUBIERTA QUE ADMITE LA SCREE?

Scree admite cubiertas de hasta 66 mm de ancho, lo que equivale a 29x2.6". Se recomienda medir la cubierta antes de instalarla, ya que el ancho real puede variar según el fabricante.



23. FAQs

¿ES COMPATIBLE LA SCREE CON RUEDA TRASERA DE 27,5"?

Técnicamente podría montarse una rueda de 27,5", pero la bici no está diseñada para configuración mullet y el motor no ofrecería un rendimiento óptimo al alterarse el diámetro de rueda. Una circunferencia menor afecta la precisión de lectura de velocidad y cosa que puede ajustarse.

Por ejemplo, montar una 27.5x2.6" reduce la velocidad de corte en 1-2 km/h y podría causar fallos con el sensor magnético.

Además, la geometría se vería comprometida pasando a un ángulo de $-1,5^\circ$ y $-13/-15$ mm en la caja del pedalier. Por lo que Mondraker no cubre garantía al montar una rueda trasera distinta de la 29" original.

¿SE PUEDE AÑADIR UNA BATERÍA EXTERNA PARA AUMENTAR LA AUTONOMÍA?

Sí. Como en cualquier motor Bosch reciente, se puede montar un extensor Bosch PowerMore 250Wh con un soporte similar al de un bidón. Pesa 1.450 g o 1.525 g incluyendo soporte y cable. Este permite aumentar la autonomía un +40% con batería interna de 600Wh o +30% con la de 800Wh.

¿QUÉ CONSIDERACIONES TENGO QUE TENER AL INSTALAR UN POWERMORE?

Bosch ofrece diferentes longitudes de cable para su Powermore range extender, y en la Scree necesitarás el de 150 mm independientemente de la talla o modelo.

El número de referencia de Bosch es: BCH3923_150 / EB12.120.036.

También es importante tener en cuenta que hay dos versiones de PowerMore según la región en la que vivas:

- EU28, CH, NO, AUS, NZ: BBP3620 / EB12.100.05G
- US, CAN, KOR: BBP3625 / EB12.100.05H

¿PUEDO LLEVAR UN BIDÓN DE AGUA?

Sí. Hay dos ubicaciones posibles: en el tubo diagonal, como en casi todas las bicicletas, y bajo el tubo superior.

EL GUIADO DE CABLES ES EXTERNO POR LOS LATERALES DE LA DIRECCIÓN, ¿SE PUEDEN GUIAR INTERNAMENTE COMO EN OTROS MODELOS?

Sí. La nueva tapa de la dirección permite enrutar los cables a través de ella y llevar todos los cables internamente si así lo prefieres.

¿SE PUEDE DESMONTAR LA BATERÍA INTERNA?

Sí. La nueva Scree permite retirar fácilmente la batería interna aflojando un tornillo Allen de 5 mm en la parte superior del tubo diagonal. La batería saldrá fácilmente permitiéndote cargar la batería fuera de la bici, cambiarla, limpiarla, o cualquier tipo de mantenimiento.



23. FAQs

TENEMOS DOS BATERÍAS (800WH Y 600WH). ¿PUEDO USAR CUALQUIERA EN LA SCREE?

Sí, todas las Scree aceptan baterías Powertube 800Wh y 600Wh.

Si tu bici viene con una u otra, siempre podrás comprar otra batería y montarla en tu Scree en función de tus preferencias. Solo asegúrate de que compras los adaptadores correspondientes (para poder montar ambas, necesitarás los adaptadores pequeños para 600Wh en el caso de que tu bici venga de serie con 800Wh, o al revés, ya que las alturas de las baterías son distintas y por lo tanto los adaptadores también) para que estas encajen correctamente.

Además, si quieres comprar una segunda batería, también te interesaría comprar otra tapa de batería en tu distribuidor Mondraker (en ese caso tendrás dos recambios listos para instalar) o simplemente sacar la tapa de la batería de serie e instalarla en la nueva, pero la espuma interna que hay entre las baterías de 600Wh y 800 Wh también son distintas.

Las baterías antiguas de 750Wh o 625Wh técnicamente podrían llegar a funcionar perfectamente en una Scree, pero Mondraker no posee ni suministra adaptadores para encajarlas en los nuevos cuadros.

La bici también puede funcionar solo con PowerMore y sin batería interna, pero Bosch no lo recomienda.

¿CUÁNTO TARDA EN CARGAR COMPLETAMENTE LA BATERÍA?

La batería Powermore 800Wh toma unas 6 horas para cargarse por completo, mientras a la de 600Wh le lleva unas 4,5 horas estando completamente descargada. Si tienes un PowerMore Range Extender, este se carga por separado y tarda aproximadamente 2,5 horas en cargarse del todo.

¿HAY ALGUNA INDICACIÓN ESPECIAL PARA LA BATERÍA?

Nada en especial. Puedes ver la carga restante en la pantalla Kiox 400c del tubo superior de la bicicleta. Cuando te queda un 30% de batería, la asistencia del motor se reduce ligeramente, y más notablemente al cuando nos queda menos de un 10%. No hay ninguna recomendación especial adicional.

LOS CAMBIOS SRAM T-TYPE DE ÚLTIMA GENERACIÓN PUEDEN ALIMENTARSE DESDE LA BATERÍA PRINCIPAL. ¿ES POSIBLE EN LA SCREE?

Sí, técnicamente es posible con los accesorios adecuados y guiando el cable internamente hasta la batería principal.

MI SCREE LLEVA TRANSMISIÓN SRAM T-TYPE. ¿PUEDO MONTAR UN GRUPO SHIMANO?

Sí, totalmente. Solo necesitas una patilla UDH adicional para el cambio Shimano.

¿CUÁL ES LA ASISTENCIA MÁXIMA DEL MOTOR BOSCH PERFORMANCE CX DE LA SCREE?

El motor Performance CX (BDU384Y) ofrece de serie 85 Nm y 600 W de pico de fuerza. Mediante la aplicación Bosch Flow puedes actualizarlo e incrementarlo hasta 100 Nm y 750 W.

¿SE PUEDEN PERSONALIZAR LOS MODOS DE ASISTENCIA EN LA SCREE?

En la app Bosch Flow puedes personalizar potencia de asistencia al pedaleo al igual que en otros Sistemas de Bosch. Regístrate en la aplicación Flow, enciende la bici y conecta tu Scree para poder ajustar la asistencia inicial mediante Dynamic, la velocidad máxima asistida en 25 km/h o 20mph y el par motor hasta un máximo de 100 Nm dentro de los 4 modos de asistencia ECO, TOUR+, EMTB+ y TURBO a tu gusto. También puedes modificar los modos a tu antojo, utilizando los 4 o menos si así lo prefieres.



23. FAQs

¿CUÁNTO PUEDO RODAR CON LA NUEVA SCREE?

Es una respuesta complicada, pues esto dependerá del modo de asistencia que estés utilizando, peso del ciclista, condición física e incluso las condiciones del terreno.

Con las nuevas baterías PT800Wh un ciclista normal de 80 kg puede hacer rutas de aproximadamente 2.000m/6.500 Pies de desnivel acumulado (1.500m/5.000pies con la batería de PT600Wh) alternando distintos modos, se pueden conseguir hasta 4 horas de ruta en ECO-TOUR+. De nuevo, dependiendo de las condiciones ambientales o el nivel de condición física del ciclista.

El PowerMore incrementa la batería un +30% (con batería 800Wh) / +40% con (con batería 600Wh) incrementando proporcionalmente las horas y la distancia de la ruta con solo un 1.5 kg de peso adicional.

USANDO POWERMORE, ¿QUÉ BATERÍA SE DESCARGA PRIMERO?

Para mantener un rendimiento constante del motor, ambas se descargan simultáneamente. Esto es clave para mantener la vida útil de las baterías y una asistencia al pedaleo constante.

Si conectas el PowerMore cuando la interna está casi vacía, este se usará como fuente de energía principal hasta igualar cargas, y entonces, ambas bajarán a la vez.

¿QUÉ INFORMACIÓN OFRECE LA PANTALLA DE LA SCREE?

Puedes consultar todos los detalles del display y mando en este enlace de Bosch: <https://www.bosch-ebike.com/es/products/kiox-400c>

QUIERO SABER MÁS SOBRE EL MOTOR BOSCH PERFORMANCE CX BDU384Y. ¿DÓNDE PUEDO INFORMARME?

Sigue este link a la web de BOSCH:

<https://www.bosch-ebike.com/en/products/performance-line-cx> y <https://www.boschebike.com/en/products/performance-line-cx-r>

¿QUÉ MANTENIMIENTO O COMPROBACIONES DE SEGURIDAD REQUIERE EL MOTOR BOSCH PERFORMANCE CX?

Ninguna en particular. No requiere lubricación ni desmontaje del motor, solo debes cuidar la bici como una bicicleta de montaña convencional.

Es importante mencionar que, como precaución aplicable a todo tipo de bicicletas, que las artes electrónicas, así como la zona del motor o el eje de bielas nunca deben ser lavados con agua a presión.

¿QUÉ TALLA NECESITO?

La nueva Scree 2026 introduce un sistema de 5 tallas, incluyendo la nueva ML entre la talla mediana (M) y grande (L). En comparación a la opción de 4 tallas de otros modelos, este sistema se ajusta perfectamente a las necesidades de cualquier ciclista.

Consulta la tabla de geometría para tener más información y todos los detalles. Aquí tienes un resumen de las medidas recomendadas para cada altura:

<165 cm	165-170 cm	170-175 cm	175-180 cm	180-185 cm	185-190 cm	190-195 cm	>195 cm
S		M/L			XL		
M			L				



Toda la información e imágenes que contiene este documento se proporcionan, únicamente, a título informativo y no constituyen un contrato legal entre Mondraker y ninguna persona ni entidad. Las especificaciones, geometrías o cualquier otra información técnica aquí publicada están sujetas a cambios sin necesidad de previo aviso.

© © Todas las marcas y modelos son propiedad de Blue Factory Team, S.L.U. y cuentan con la protección de las leyes vigentes y los acuerdos internacionales de aplicación.

